

**PRESA DI FORZA A
COMANDO PNEUMATICO
PNEUMATIC CLUTCH
POWER TAKE-OFF**

CODICE PTO
PTO CODE

10-28

CAMBIO
GEARBOX

ZF



DIAGRAMMA DI UTILIZZO
WORKING CONDITION

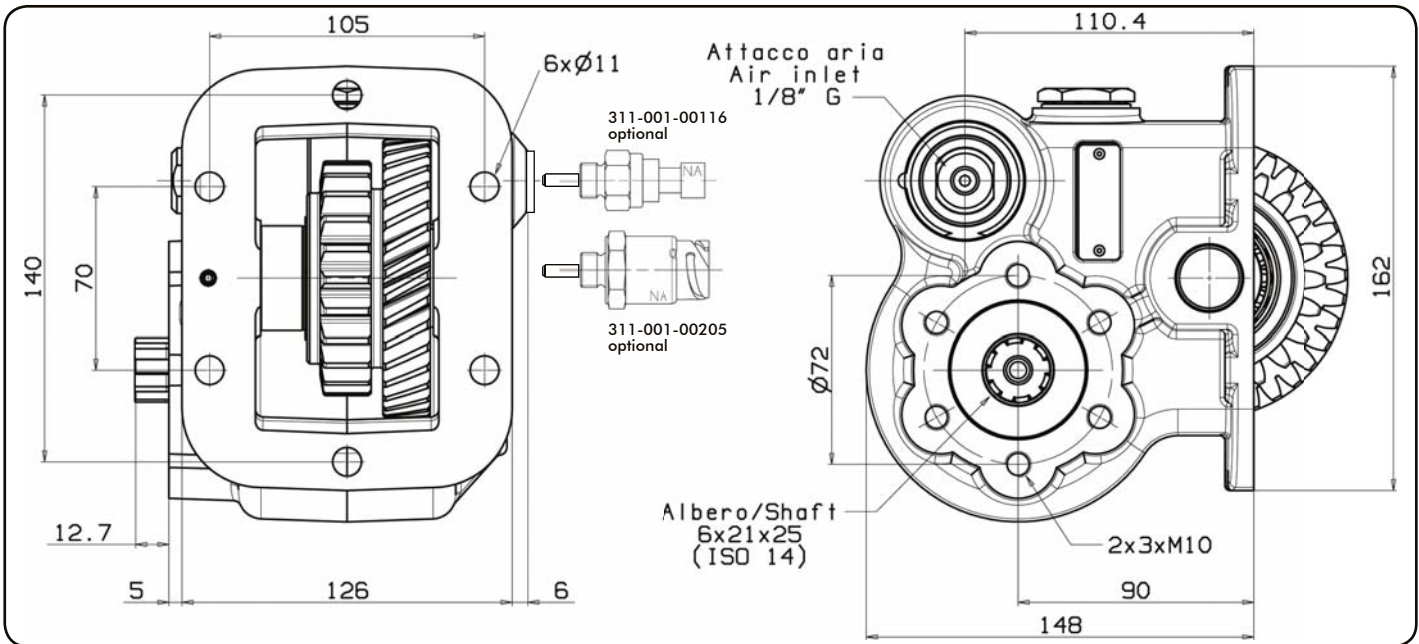
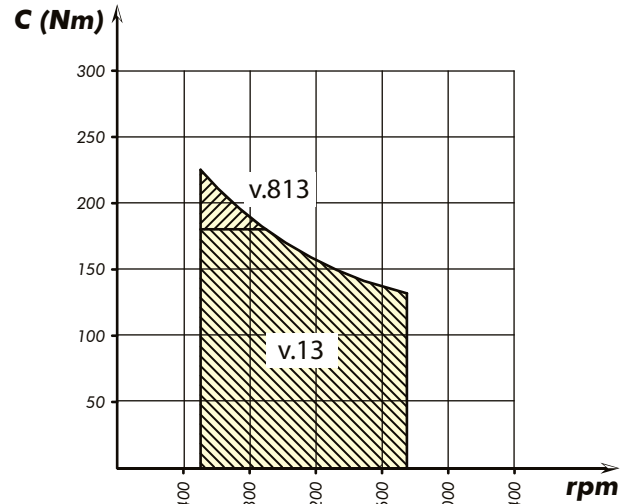

Tipo cambio Gearbox	Codice PTO PTO code	Versione Version	Giri pto a 1000 giri motore Pto ratio@1000 eng.rpm	Coppia massima Max torque	Lato montaggio Mounting side	Uscita Output	Rotazione Rotation	Kit di montaggio Mounting kit	Peso Weight
			rpm	Nm					Kg
S5-42/ 4,65-0,77	010-028-00131	13	680	180	Dx-Sx Right-Left	Poster. Rear	Ora. Cw	154-3-3053	9,9
	010-028-08133	813		230					10

Data: Mercoledì 07 dicembre 2016

Codice foglio: 997-210-02813 Rev: AC