

SERBATOIO COMPLETO DI VALVOLA A COMANDO PNEUMATICO PNEUMATIC TIPPING VALVE WITH TANK

FAMIGLIA / FAMILY **146**
CAPACITÀ / CAPACITY Lt **10/15**
VALVOLA / TIPPING VALVE **FP80**

99740013510

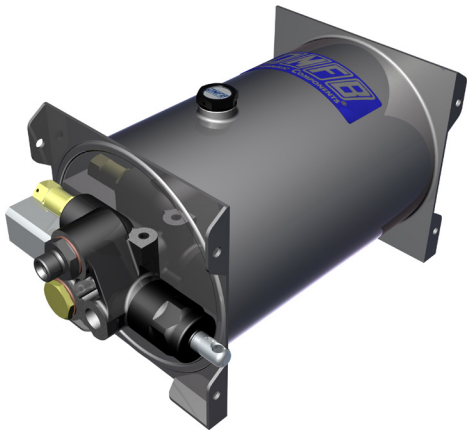

Serbatoio completo di valvola ad azionamento meccanico, per il comando di ribaltabili leggeri, con schema idraulico a centro aperto in accordo alle direttive CE.

- Valvola di ritegno e valvola di massima pressione registrabile incorporate;
- Predisposizione per segnalatore di pressione;
- Corpo valvola protetto da cataforesi nera, cursore nichelato e serbatoio verniciato con polveri epossidiche grigie (RAL 7020);
- Garantito per lavorare con olio a temperature -25÷80 °C, campo di viscosità 12÷100 cSt e grado di filtrazione 25 µm;

Oil tank with mechanically-activated tipping valve to suit light duty tipper trucks. Open centre hydraulic layout according to CE standards.

- Built-in adjustable safety valves.
- Ready for pressure signal switch mounting
- Cataphoresis coated valve body, nickel spool and tank painted with grey epoxy powder (RAL 7020);
- Guaranteed for working with oils at -25÷80 °C, viscosity range 12÷100 cSt and oil filtering level of 25 µm.

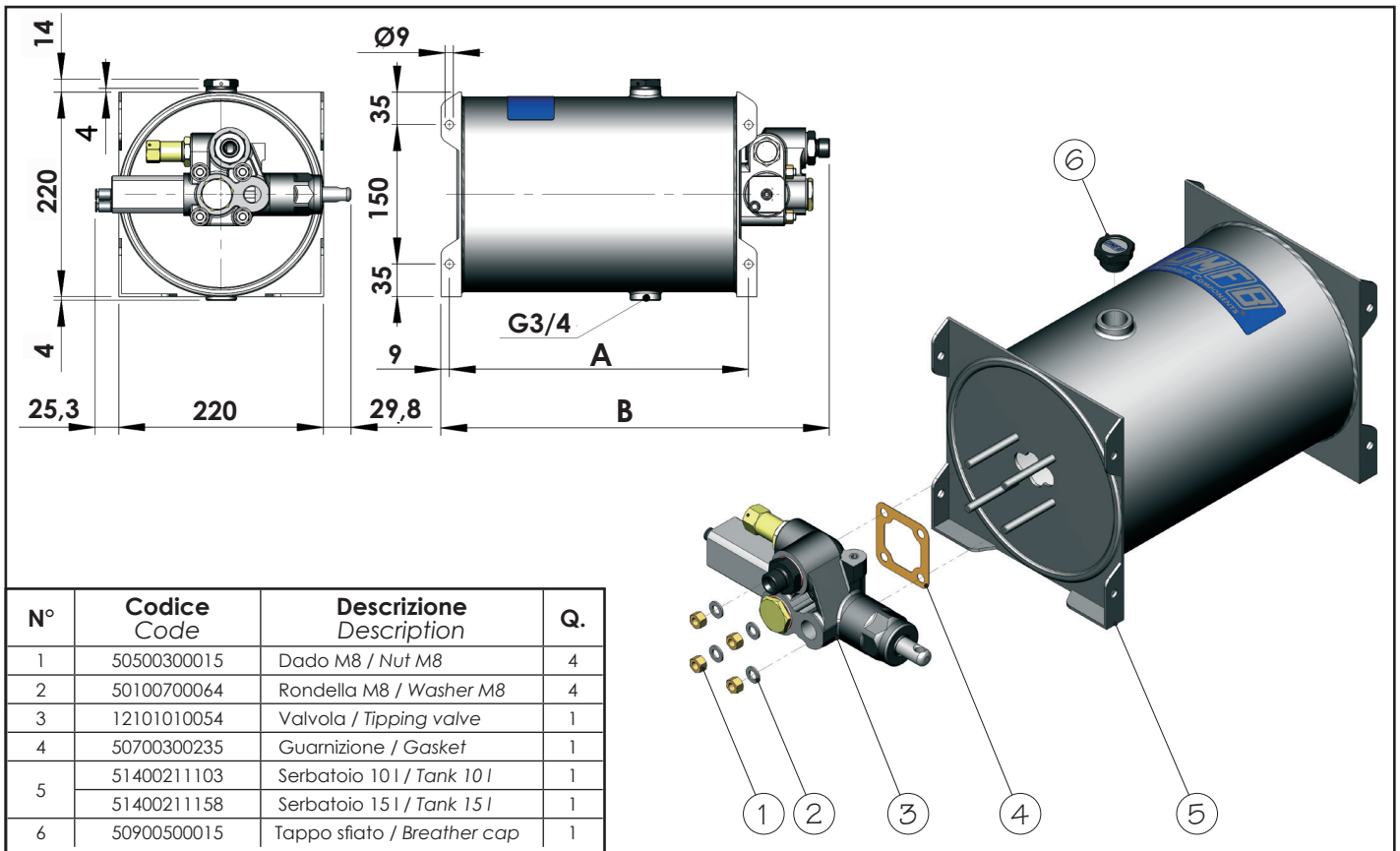

27/04/2021

99714608510 Rev: AB

Tipo Type	Codice ordinazione Order code	Capacità serbatoio Tank's capacity	Portata valvola Valve Flow	A	B	Pressioni Pressure values	
						Taratura standard Standard setting	Taratura massima Maximum setting
		l	l/min	mm	mm	bar	bar
DSP-10 CE	14608501018	10	80	322	418	140	300
DSP-15 CE	14608501518	15		472	568		

pag.101



O.M.F.B. S.p.A. Hydraulic Components
We reserve the right to make any changes without notice.
Edition 2004.09 No reproduction, however partial, is permitted.
Via Cave, 7/9 25050 Provaglia d'Isèo (Brescia) Italy Tel.: +39.030.9830611
Fax: +39.030.9839207-208 Internet:www.omfb.it e-mail:contatti@omfb.it

COMPANY WITH
QUALITY SYSTEM
CERTIFIED BY DNV GL
= ISO 9001:2015 =