

DEVIATORE OLEODINAMICO A COMANDO PNEUMATICO

CODICE FAMIGLIA
FAMILY CODE

121-022

PNEUMATIC DIVERTER VALVE

**3 VIE 3 POSIZIONI
3 WAY 3 POSITIONS**
centro aperto - open center



Deviatore 3 vie ad azionamento pneumatico per alimentazione indipendente o contemporanea di due circuiti oleodinamici, tipicamente utilizzato per impianti a doppia cassa su semirimorchio o motrice/rimorchio.

- Portata fino a 250 l/min.
- Pressione fino a 400 bar.
- Corpo zincato e cursore nichelato.
- Garantito per lavorare con olio a temperature -15+110°C, campo di viscosità 12÷100 cSt e grado di filtrazione 25 µm.

Pneumatic 3-way high pressure diverter valve to control 2 pressure lines separately. Especially designed for semi-trailers and truck/trailer.

- Flow up to 250 l/min.
- Pressure up to 400 bar.
- Galvanized body and nickel spool.
- Guaranteed for oil temperature range -15+110 °C, viscosity range 12÷100 cSt and oil filtering 25 µm.

Codice fascicolo: 997-400-12120

Data: Lunedì 13 gennaio 2020

Codice foglio: 997-121-02201 Rev: A1

Schema di funzionamento Functional diagram

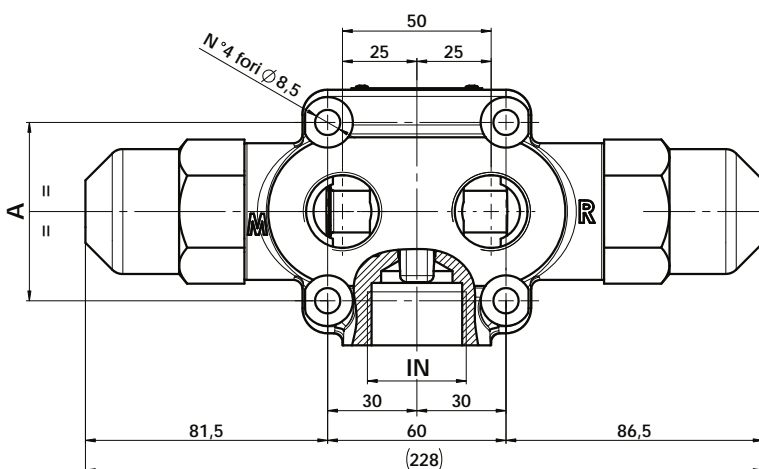
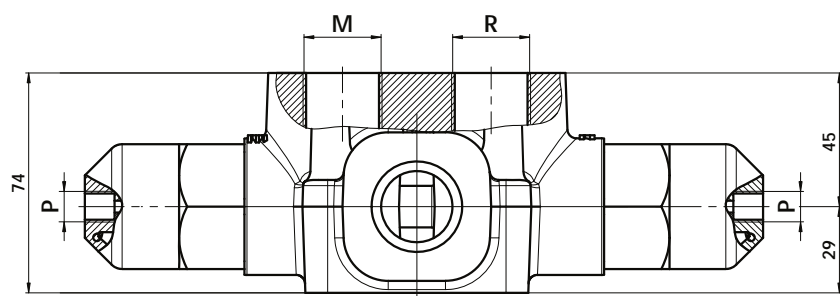
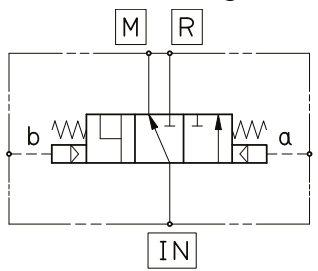

Tipo deviatore Tipping valve type	Codice Order code	Pressione / Pressure		Portata Flow l/min	Peso Weight kg
		Esercizio In service bar	Max Max peak pressure bar		
SEL 250-3	121-022-00123	350	400	250	3
	121-920-00260				

Tipo deviatore Tipping valve type	Codice Order code	P	A	IN	R	M
SEL 250-3	121-022-00123	G1/8	60	G1	G3/4	G3/4
	121-920-00260	1/8NPT	65	1 5/16-12 UN-2B	1 5/16-12 UN-2B	1 5/16-12 UN-2B

pag.165

OMFB
HYDRAULIC COMPONENTS

O.M.F.B. S.p.A. Hydraulic Components
We reserve the right to make any changes without notice.
Edition 2003.03 No reproduction, however partial, is permitted.
Via Cave, 7/9 25050 Pravglio d'Iseo (Brescia) Italy Tel.: +39.030.9830611
Fax: +39.030.9839207-208 Internet:www.omfb.it e-mail:contatti@omfb.it

COMPANY WITH
QUALITY SYSTEM
CERTIFIED BY DNV GL
= ISO 9001:2015 =

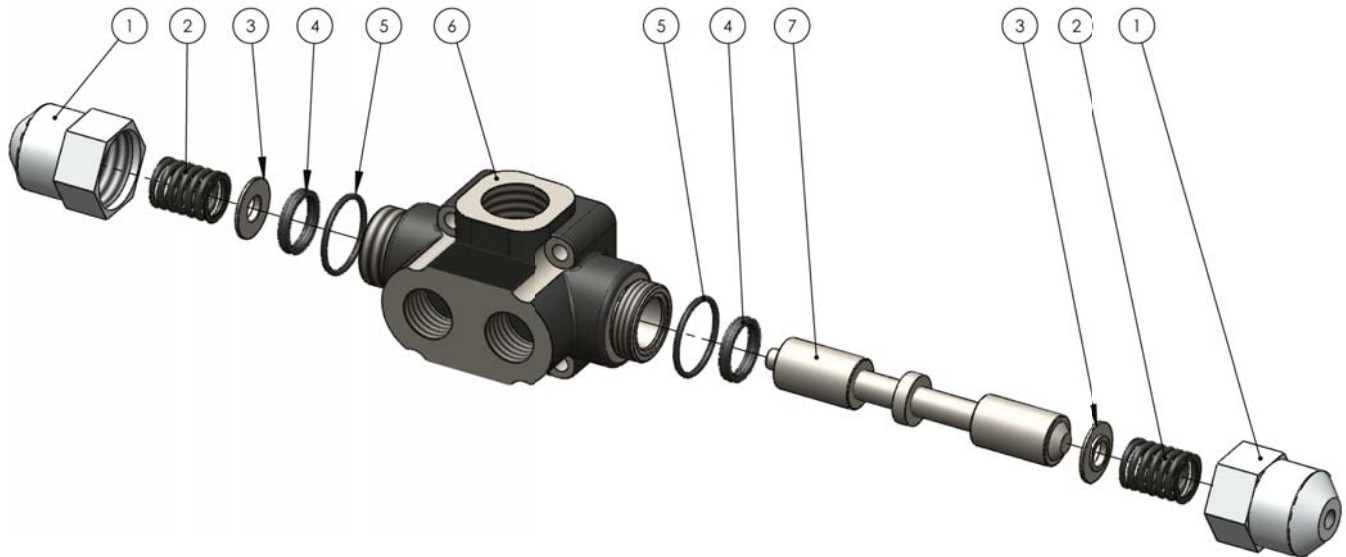

Codice fascicolo: 997-400-12120

N°	Codice P. Number			Descrizione Description	
		121-022-00123	121-920-00260		
1	537-004-00133	2	--	Cilindro pneumatico deviatore	Distributor pneumatic cylinder
	537-004-00811	--	2		
2	512-006-00357	2	2	Molla	Spring
3	530-004-00128	2	2	Distanziale 12,5x30x4	Spacer 12,5x30x4
4	506-000-01300	2	2	Guarnizione tenuta Ø 25	Seal gasket
5	506-002-00274	2	2	Guarnizione OR (2,62 x 34,60)	O-Ring (2,62 x 34,60)
6	520-003-00157	1	--	Corpo deviatore	Distributor body
	520-003-01021	--	1		
7	536-003-00181	1	1	Cursore	Spool

Data: Lunedì 13 gennaio 2020

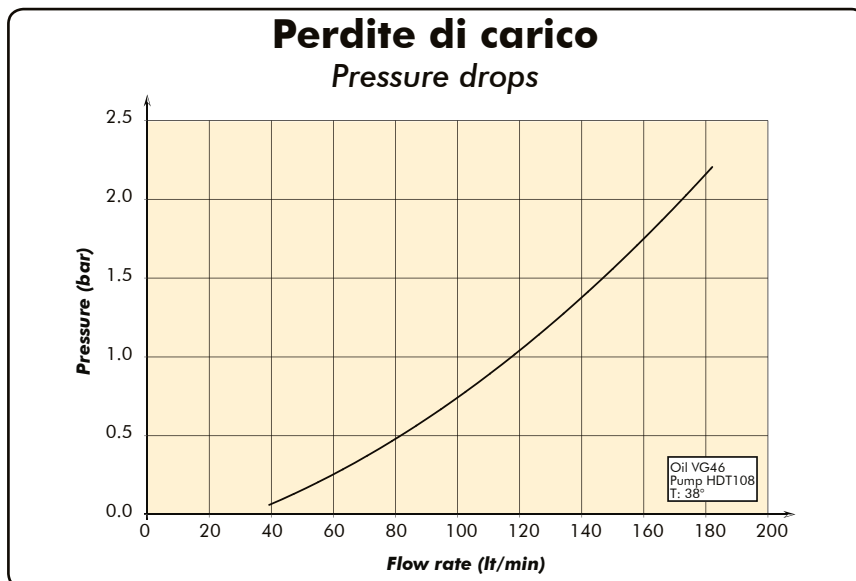

Codice foglio: 997-121-02201 Rev: A1