

DEVIATORE OLEODINAMICO PROPORZIONALE A COMANDO PNEUMATICO PROPORTIONAL PNEUMATIC TIPPING VALVE

CODICE
CODE

121-018-10305

“MODUL-TRUCK 250”

“PILOT-ITALIA”

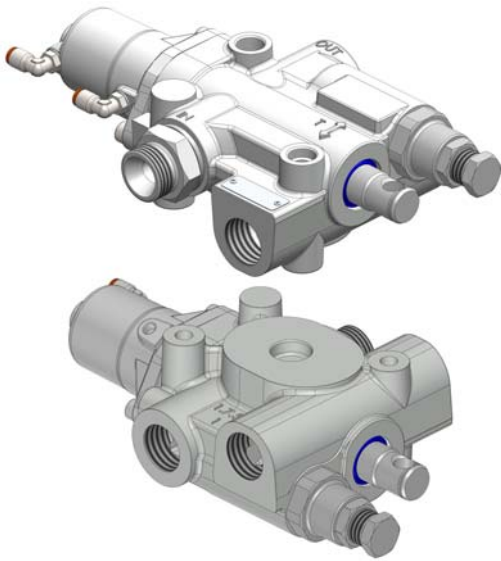

Valvola oleodinamica ad azionamento pneumatico, specificatamente studiata per l'azionamento di semirimorchi ribaltabili abbinati a trattori stradali. Il layout delle bocche, e nello specifico la presenza del doppio scarico laterale, consente un rapido e razionale collegamento delle tubazioni con conseguente risparmio di tempo e raccorderia dedicata. La valvola ha uno schema oleodinamico a centro aperto in accordo con le direttive CE ed include valvola di non ritorno in ingresso e valvola di massima di tipo pilot registrabile incorporate. L'utilizzo abbinato ad un comando pneumatico proporzionale (tipo N-Force) consente di modulare la velocità di discesa del cassone ribaltabile.

- Corpo in ghisa sferoidale con trattamento di zincatura bianca.
- Predisposizione per segnalatore di pressione / attacco manometro.
- Range di temperatura -15+110°C, range di viscosità consigliata 12-100 cSt, grado di filtrazione consigliata 25 micron.
- Foratura di fissaggio intercambiabile con Modular 250.

Pneumatically operated hydraulic tipping valve especially designed for tippers on semitrailers connected to tractor trucks. The ports position as well as double side oil return option included allow quick and effective pipes connection resulting in time and fittings saving. The valve layout is open centre according to the EC directive and includes a check valve on the pump input port as well built-in adjustable relief valve pilot type. If used in combination with proportional air control valve (like our N-Force series) you can adjust the lowering speed of the tipper body.

- Casing made out of nodular cast iron with white zinc coating
- Ready for pressure switch / gauge port.
- Temperature range: -15+110°C, recommended viscosity range 12-100 cSt, recommended filtration grade 25 micron.
- Mounting dimensions fully interchangeable with Modular 250 valves.

Codice fascicolo: 997-400-12120

Data: Lunedì 26 agosto 2019

Rev: AA

Codice foglio: 997-121-01808

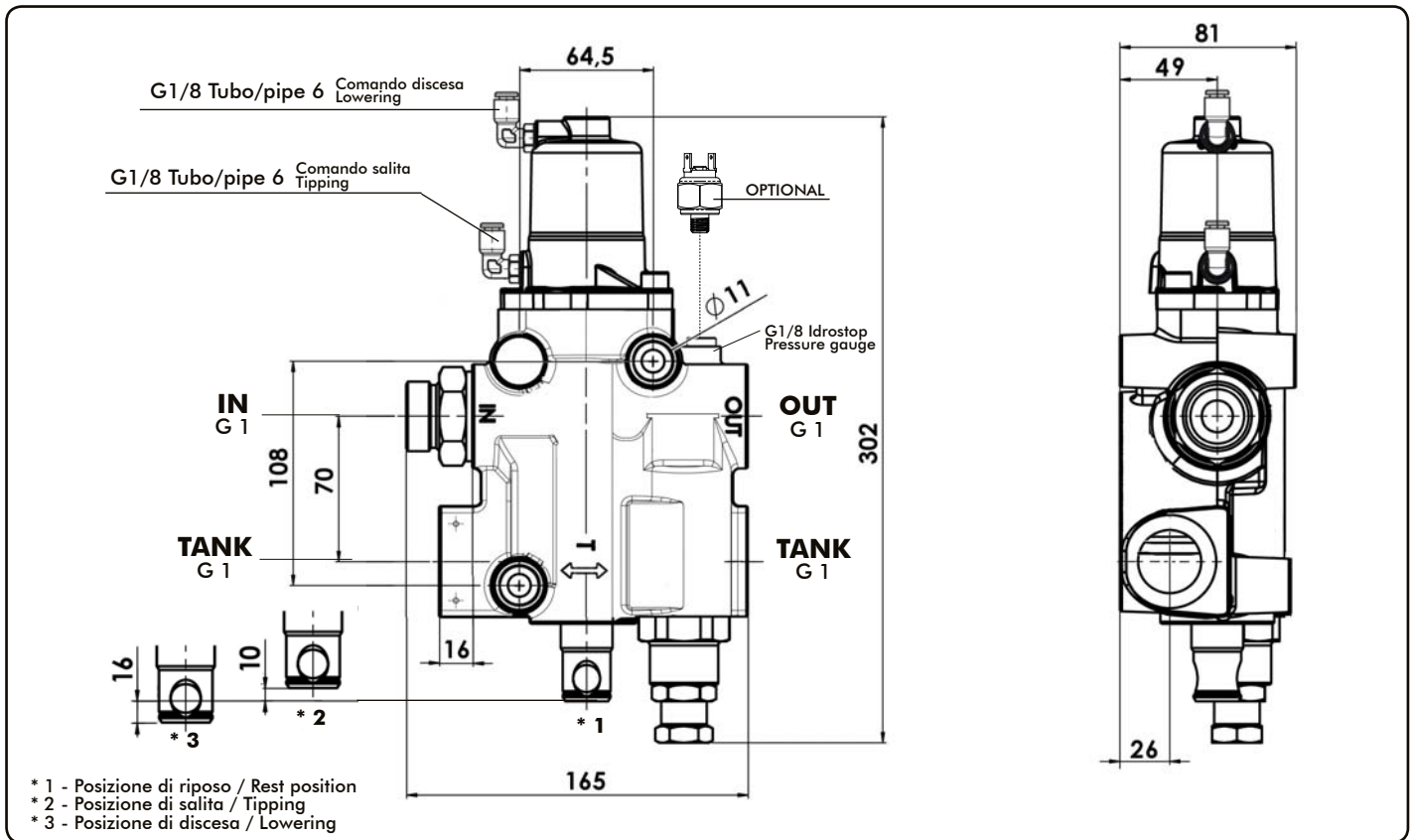

Tipo deviatore Tipping valve type	Codice ordinazione Order code	IN	TANK	OUT	Peso Weight Kg
MODUL-TRUCK 250 CE ITALIA	121-018-10305	ISO 228 G 1	ISO 228 G 1	ISO 228 G 1	7.9

pag.139



O.M.F.B. S.p.A. Hydraulic Components
We reserve the right to make any changes without notice.
Edition 2003.03 No reproduction, however partial, is permitted.
Via Cave, 7/9 25050 Pruvaglio d'Isco (Brescia) Italy Tel.: +39.030.9830611
Fax: +39.030.9839207-208 Internet: www.omfb.it e-mail: contatti@omfb.it

COMPANY WITH
QUALITY SYSTEM
CERTIFIED BY DNV GL
= ISO 9001:2015 =

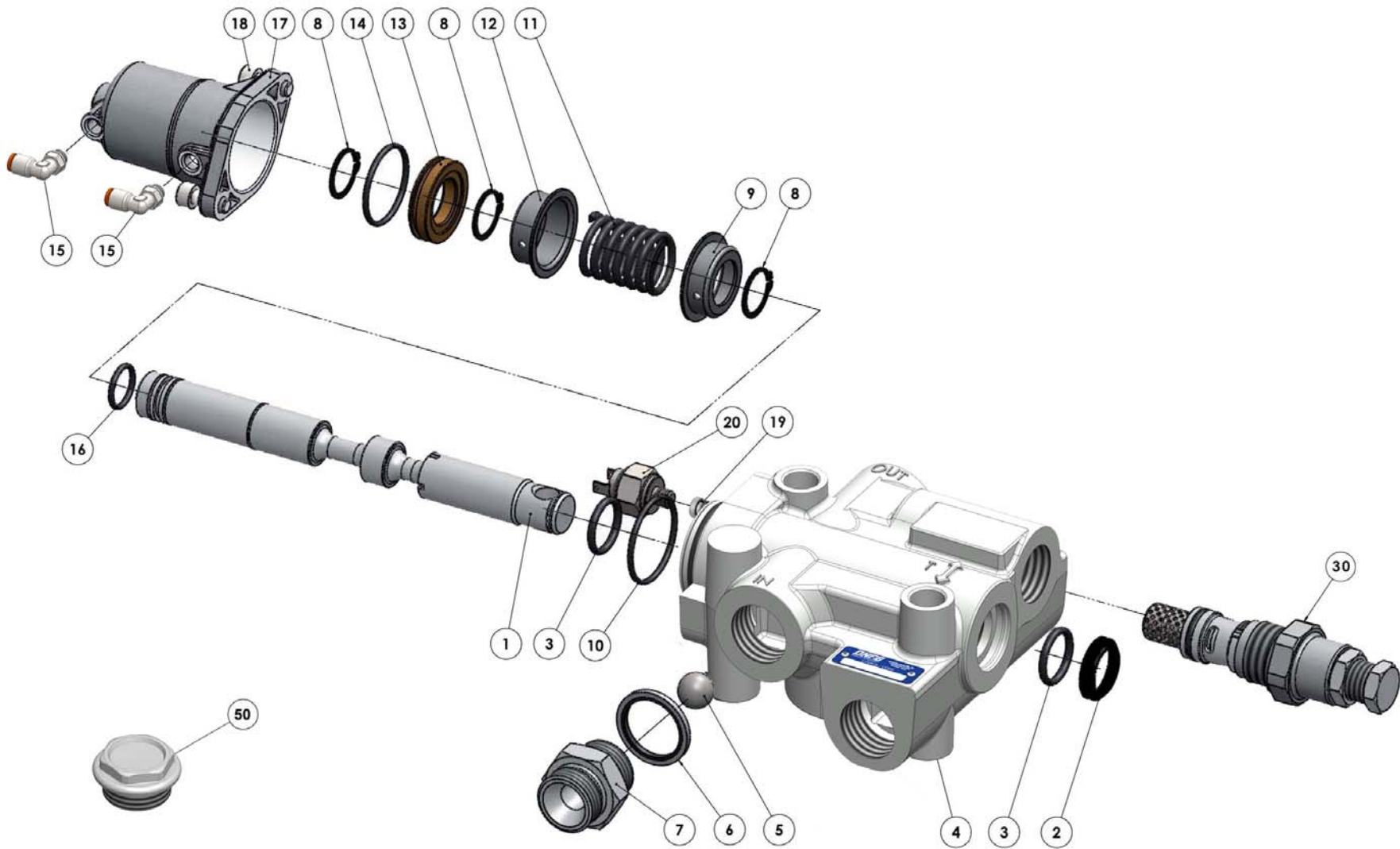

pag. 140

COMPANY WITH
QUALITY SYSTEM
CERTIFIED BY DNV GL
= ISO 9001:2015 =

O.M.F.B. S.p.A. Hydraulic Components

We reserve the right to make any changes without notice.

Edition 2003.03 No reproduction, however partial, is permitted.

Via Cove, 7/9 25050 Pionoglia di Isco (Brescia) Italy Tel.: +39.030.9830611
Fax: +39.030.9839207-208 Internet: www.omfb.it e-mail: comfah@omfb.it

OMFB
HYDRAULIC COMPONENTS

N°	Codice / P. Number	Descrizione / Description		Q.
1	536-003-00583	Cursore Ø 25	Spool Ø 25	1
2	506-000-01819	Guarnizione raschiatore poliuretano	Polyurethane scraper seal	1
3	506-003-00059	Guarnizione OR (3,53 x 24,99)	O-Ring (3,53 x 24,99)	2
4	520-003-00915	Corpo deviatore	Distributor body	1
5	510-009-00214	Sfera 3/4"	Ball 3/4"	1
6	116-009-11002	Rondella acciaio-gomma	Steel-rubber washer	2
7	540-007-00204	Tappo	Plug	1
8	501-002-00229	Anello seeger	Circlip	3
9	534-001-00141	Anello guida molla	Spring guide ring	1
10	506-002-00336	Guarnizione OR (2,62 x 44,12)	O-Ring (2,62 x 44,12)	1
11	512-006-00302	Molla ritorno cursore	Spool return spring	1
12	534-001-00203	Anello guida molla	Spring guide ring	1
13	532-003-00143	Pistone	Piston	1
14	506-002-00309	Guarnizione OR (2,62 x 39,34)	O-Ring (2,62 x 39,34)	1
15	100-017-00188	Raccordo 90° 1/8" tubo 6	Fitting 1/8" pipe 6	2
16	506-002-00158	Guarnizione OR (2,62 x 20,24)	O-Ring (2,62 x 20,24)	1
17	537-004-00615	Cilindro pneumatico	Pneumatic cylinder	1
18	502-003-00548	Vite TCE M8x20 UNI 5931	Screw TCE M8x20 UNI 5931	2
19	115-009-00016	Tappo acciaio 1/8"	Steel plug 1/8"	1
20	122-009-00011	Idrostop (OPTIONAL)	Pressure switch (OPTIONAL)	1
30	121-090-20145	Valvola di massima PILOT	PILOT relief valve	1
50	115-006-10151	Tappo TE G1	TE G1 plug	1

Tipo deviatore Tipping valve type	Codice ordinazione Order code	Pressioni / Pressure values		Portata Flow l/min
		Taratura standard Standard pressure setting bar	Taratura massima Max. pressure setting bar	
MODUL-TRUCK 250 CE-ITALIA	121-018-10305	180	350	250

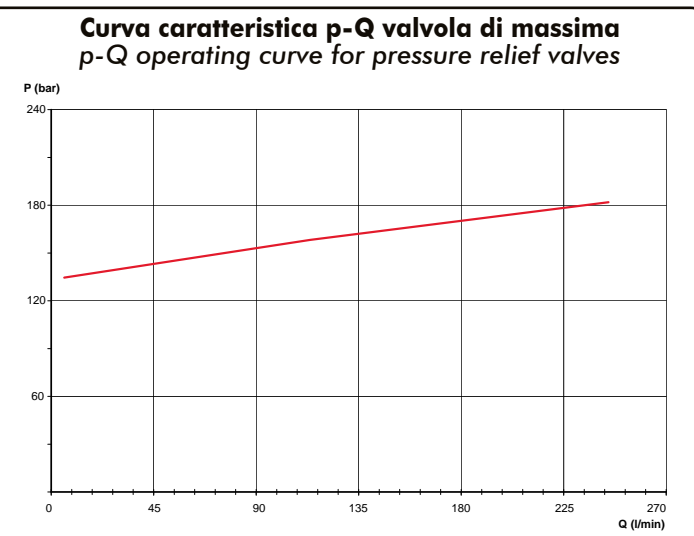
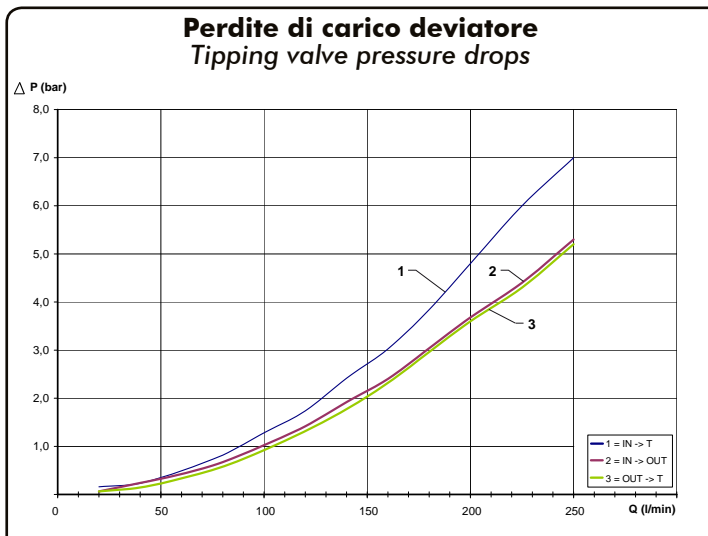

Rilievi eseguiti con olio ISO VG 46 a 40°
The graph refers to oil type ISO VG 46 a 40°

CODICE / CODE	DESCRIZIONE / DESCRIPTION
121-901-10150	150 bar
121-901-10160	160 bar
121-901-10170	170 bar
121-901-10180	180 bar
121-901-10190	190 bar
121-901-10200	200 bar
121-901-10210	210 bar
121-901-10220	220 bar
121-901-10230	230 bar
121-901-10240	240 bar
121-901-10250	250 bar
121-901-10260	260 bar
121-901-10270	270 bar
121-901-10280	280 bar
121-901-10290	290 bar
121-901-10300	300 bar

Sigillo e taratura valvola di massima
Safety sealing with relief valve settings



Kit guarnizioni / Seal kit:
121-900-02057

Kit fissaggio codice: 121-994-01323
Mounting kit p/n:

Q.	Descrizione / Description
2	Vite TCE M10 L=90mm UNI 5931 Screw M10 TCE L=90mm UNI 5931
2	Rondelle elastiche SCHNORR x M10 Schnorr washer M10
2	Dado per M10 UNI 5587 Nut M10 UNI 5587

