

Ingresso ISO
 ISO input



Uscita ISO
 ISO output



Ingombro / Dimension

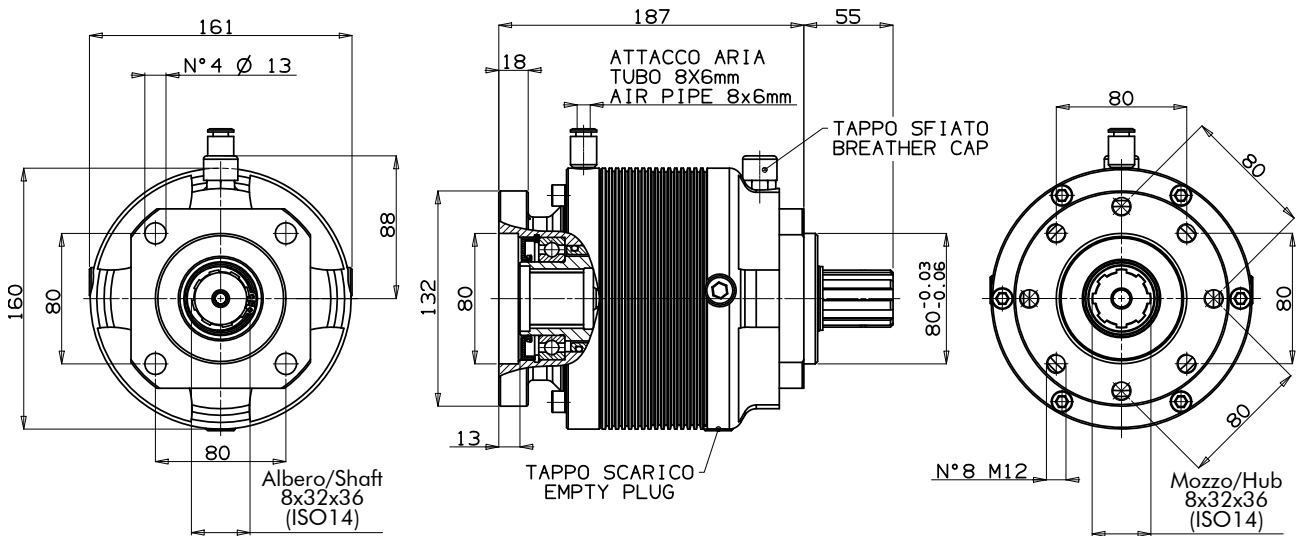

Dati tecnici / Technical features

Codice di ordinazione Order code	Versione ingresso Input version	Versione uscita Output version	Coppia nominale Nominal torque	Velocità max. continua Max. continuous speed		Velocità max. intermittente Max. intermittent speed		Peso Weight
			Nm	A vuoto Unloaded	Sotto carico Loaded	A vuoto Unloaded	Sotto carico Loaded	
10301100017	15	17	400	2600	1500	3200	2000	11,8 Kg