



**QUASAR 6-12 CH FM**



**QUASAR 2-4 CH FM**

<b>1. General comments</b> .....	pag. 23
1.1 Product Markings and certification .....	pag. 23
1.2 New safety feature .....	pag. 25
1.3 OMFB QUASAR Radio remote control systems .....	pag. 25
1.4 QUASAR receiver .....	pag. 25
1.5 QUASAR transmitter .....	pag. 26
<b>2. Installation and mechanical fastening of the receiver</b> .....	pag. 27
2.1 General comments .....	pag. 27
2.2 Positioning the receiver .....	pag. 27
2.3 Fastening the receiver .....	pag. 27
2.4 Insertion in additional housings .....	pag. 28
2.5 Electric connection .....	pag. 28
2.6 Level of protection of receiver and important Notes for wiring assembly .....	pag. 28
<b>3. Technical specifications</b> .....	pag. 29
3.1. QUASAR transmitter apparatus .....	pag. 29
3.2. QUASAR Receiver apparatus 6-12 CH. FM .....	pag. 29
3.2. QUASAR Receiver apparatus 2-4 CH. FM .....	pag. 29
<b>4. Electrical specifications</b> .....	pag. 29
4.1. Electrical specification of the admissible loads .....	pag. 29
4.2 Connecting devices to the receiver .....	pag. 30
4.3 Setting the output type (Single / Double Acting) .....	pag. 32
<b>5. Emergency stop</b> .....	pag. 34
5.1 Emergency Stop engaged by the Transmitter .....	pag. 34
5.2 Emergency Stop engaged by the Receiver .....	pag. 34
<b>6. Using the system</b> .....	pag. 34
6.1 Using the transmitter .....	pag. 34
6.1.1 Radiocontrols 14/16/24/36 channels - Special Versions .....	pag. 35
6.2 Programming procedure .....	pag. 35
6.3 Reset after emergency .....	pag. 36
6.4 Motor auxiliary .....	pag. 36
<b>7. Frequently asked questions</b> .....	pag. 37

**1.1 Product marking and certification**

**QUASAR** radio remote controls meets the rules set forth in the following harmonised technical standards:

2014/53/EU Regulation concerning the unification of member countries' legislation regarding the presence of radio devices on market and revoking the regulation 1999/05/CE.

- Art. 3.1 (a) - SALUTE - EN 62479: 2010 Assessment of the compliance of low power electronic and electrical equipment with the basic restrictions related to human exposure to electromagnetic fields (10MHz - 300GHz).
- Art. 3.1 (a) - SICUREZZA - EN 60950-1:2006 + A11:2009 + A1:2010 + A12:2011+ AC:2011+ A2:2013 Information technology equipment - Safety  
Part 1: General requirements.
- Art. 3.1 (b) - COMPATIBILITA' ELETTROMAGNETICA - EN 301 489-3: v2.1.1 (2017-03) ElectroMagnetic Compatibility (EMC) standard for radio equipment and services; Part 3: Specific conditions for Short-Range Devices (SRD) operating on frequencies between 9 kHz and 246 GHz; Harmonised Standard covering the essential requirements of article 3.1(b) of Directive 2014/53/EU.
- Art 3.2 - SPETTRO RADIO - EN 300 220-2: v3.1.1 (2017-02)  
Short Range Devices (SRD) operating in the frequency range 25 MHz to 1 000 MHz; Part 2: Harmonised Standard covering the essential requirements of article 3.2 of Directive 2014/53/EU for non specific radio equipment.

Compliance with pertinent directives is certified by the presence of the **CE Marking** on the product:



The compliance of **QUASAR** radio remote controls with essential requirements of Directive 99/05/EC **allows them to be placed on the market, put into service and have the right to be connected in every European country**, as well as all countries belonging to CEPT, **without the need for homologation by the relevant Postal and Telecommunications Administration.**

According to an indicative and non-exhaustive list of equipment that falls within the classification established by **European Commission Decision 2000/299/EC**, **QUASAR** radio remote controls are not subject to any restrictions for installation and connection, since they belong to a class of S.R.D. (Short Range Devices) without specific uses and operating within a radio frequency band (433.050 – 434.790 MHz) harmonized within the European Community.

## 1. GENERAL COMMENTS

---

The **QUASAR** radio remote control **receiver** also **complies with the essential requirements and other provisions set forth in European Directive 95/54/EC and in ECE/ONU Regulation No 10 Addendum 2**, relating to “Suppression of radio interference (Electromagnetic Compatibility) produced by spark-ignition engines fitted to motor vehicles”.

Concerning to **Electromagnetic Compatibility 95/54/EC** is the reference directive for every electrical/electronic system included in road vehicles because it constitutes a “specific directive” for the purposes of Article 2, par. 2, of Council Directive 89/336/EC, effective beginning 1 January 1996.

The provisions of 95/54/EC must be satisfied, concerning Electromagnetic Compatibility, by all vehicles as defined in Directive **70/156/EC** relating to the **type-approval of motor vehicles and their trailers**, as amended by 92/53/EC, as well as their **components or separate technical units** that are exempt from the compliance with the rules of 89/336/EC.

Conformity tests prescribed by Directive 95/54/CE and ECE/ONU Reg. No 10 Add. 9 were carried out at the laboratory **IMQ S.p.A.** (via Quintiliano, 43 I-20138 Milano).

Compliance of **QUASAR** radio remote controls with Dir. 95/54/EC requirements is **certified by the Notified Body NSAI** by releasing the approval number for the product marking:

e24\*72/245\*95/54\*1107\*00.

Compliance is shown by product marking:



Compliance of **QUASAR** radio remote controls with the ECE/ONU Reg. No 10 Add. 9 requirements is **certified by the Notified Body NSAI** by releasing the approval number for the product marking:

E24 10R-020185.

Compliance is shown by product marking:



# 1. GENERAL COMMENTS

## 1.2 New safety features (only for 6-12 CH.)

When the receiver is in an emergency condition, you can start it up again from the sender by pressing one of the transmitter buttons (except for the SOS one) and holding it pressed for 5 seconds and then release it for at least 2 seconds before starting to operate.

After 20 minutes of inactivity, the receiver turns off automatically (only 6-12 CH).

**NOTE:** the emergency button, if pressed, should be reset before proceeding with the reactivation of the receiver.

## 1.3 OMFB QUASAR radio remote control system

The radio remote control system consists of the following components:

- 1 receiver
- 1 transmitter QUASAR to control 2- to 12-channel systems)

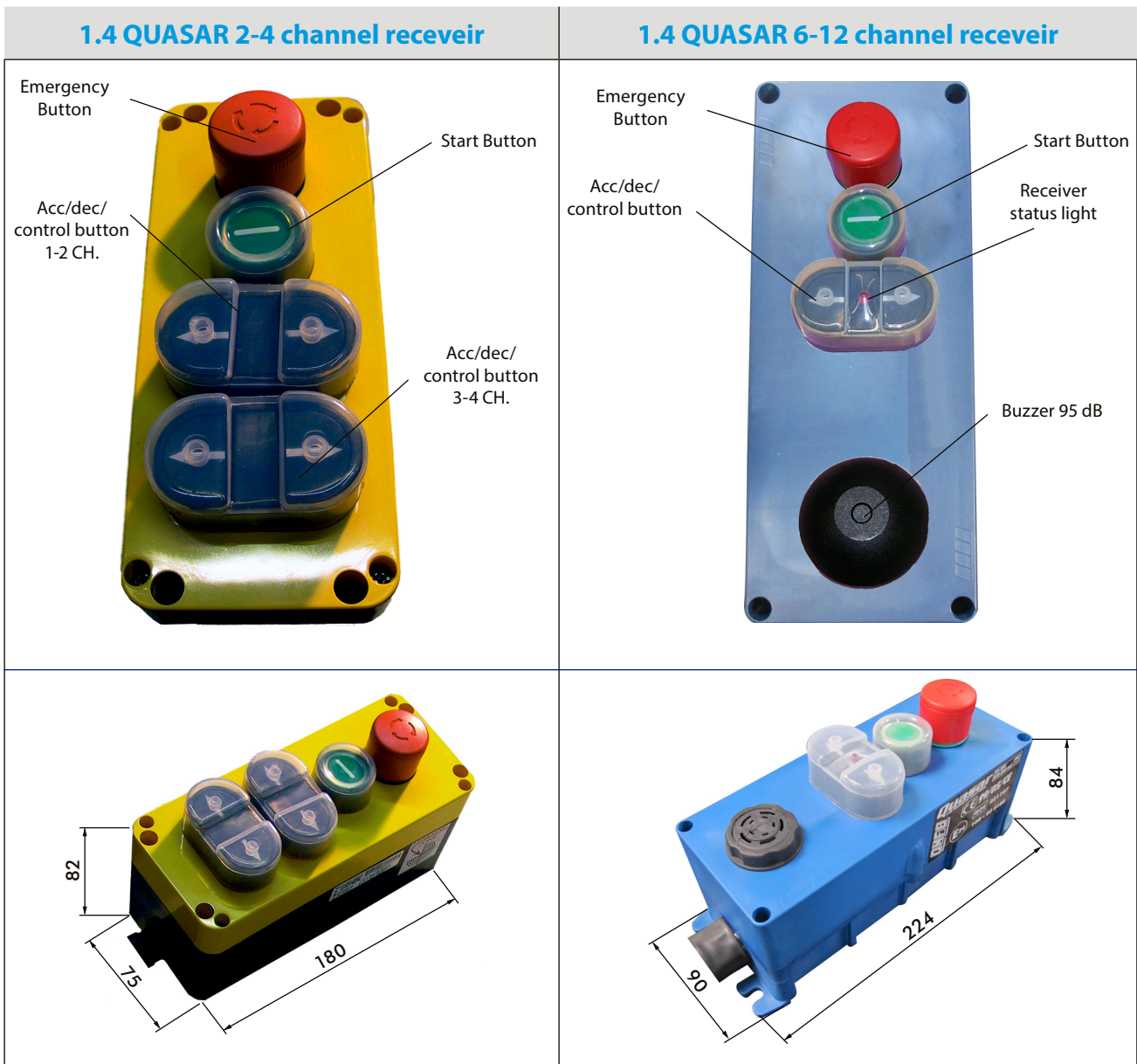

# 1. GENERAL COMMENTS

## 1.5 QUASAR transmitter

To control configurations with 2, 2+2, 4, 6, 8, 10, and 12 channels.



Battery charger connection

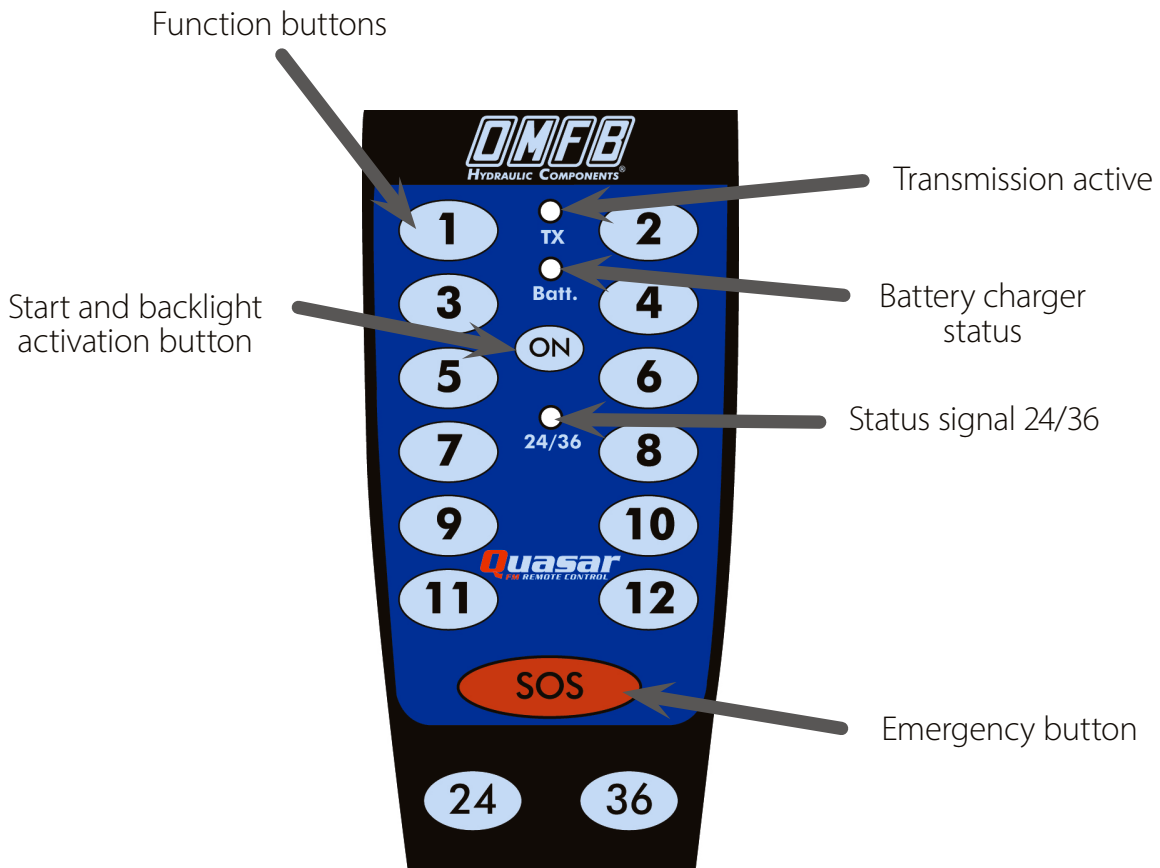

## 2. INSTALLATION AND MECHANICAL FASTENING OF THE RECEIVER

### 2.1 General comments

The receiver **must be installed using the 2 screws already present on the receiver**, and **must not be opened or drilled** for any reason. For applications involving strong vibrations, it is recommended to insert the appropriate anti-vibration material between the external housing of the receiver and the support to which it is fastened. **Any opening, drilling or similar operations on the receiver not previously agreed upon with OMFB will void the product warranty.**

The following factors must be taken into consideration when choosing the receiver position on the vehicle:

- The red mushroom-head Emergency Stop button must be easily accessible;
- The best reception capacity is obtained by placing the receiver as high as possible off the ground;
- Whenever possible, the receiver should be clearly visible from the transmitter work area.
- The field radiates concentrically from the antenna; in the case of receivers without external antenna, the latter is aligned with the receiver box.

### 2.2 Positioning the receiver

Install the receiver with the cable input facing **down**, never upwards.

↑↑↑  
TOP  
UPPER SIDE

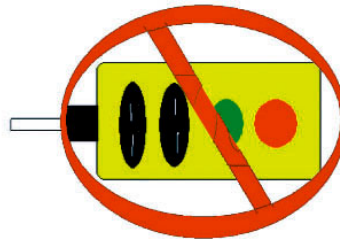

### 2.3 Fastening the receiver

To fasten the receiver you must take advantage of the prigionieri already present on the receiver box. **Do not drill any holes in the box, under penalty of voiding the product warranty.**

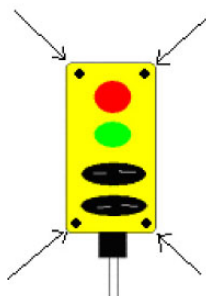

### 2.4 Insertion in additional housing

The receiver may be inserted in an additional housing **as long as it is made of plastic and not metal.**

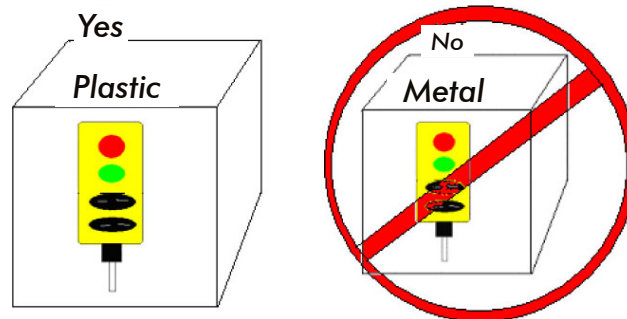

Insertion in a metal housing must absolutely be agreed upon and assessed with OMFB staff to avoid unpleasant malfunctions.

### 2.5 Electric connection

The power supply line (+12/24V batt and ground) should lead to the receiver directly from the main source (battery or stabilized power source), with cables adequately sized for the load to be carried (cross-section of at least 1 mm<sup>2</sup>), also using a **safety fuse**.

The power supply line to the receiver must be kept **locked, or under a switch dedicated** specifically to the radio remote control system, or under an appropriately sized battery disconnecter.

**It is essential that the radio remote control system never be powered while the vehicle is running: the installer is responsible for informing the system end user of this fact.**

**It is essential, while performing manoeuvre operations, that other FM radio devices (Quasar and not) are not active and / or are not working in a perimeter of 100 meters in order to avoid any interference or accidental switching.**

**During maintenance, disconnect power from the transmitter.**

**It is compulsory to remove the programming from the receiver before programming it again.**

### 2.6 Level of protection of receiver and important notes for wiring assembly

The product, as supplied by OMFB, is not to be considered IP65 as the product is equipped with a metre of sheath and wires without tin ending.

The casing of the receiver and the buttons guarantee the IP65 level of protection if the wiring is connected according to the rules of the trade.

It is the installer's responsibility to connect the wiring taking all the necessary precautions, according to the rules of the trade, using suitable derivation boxes and/or sufficiently suitable isolation systems, in order to guarantee the IP65 level of the complete product.

An incorrect wiring assembly leads to the loss of the level of protection of the receiver.

OMFB categorically passes all responsibility for the wiring of the system onto the final installer.



### 3. TECHNICAL SPECIFICATIONS

#### 3.1 Transmitter apparatus QUASAR

- Modulation FSK  $\pm 20$  KHZ
- Working frequency: 433,92 MHz $\pm$ 75KHz
- Power RF E.R.P. a 433,92 MHz: 1 $\div$ 3 mW
- Battery 2x1,2V/NiMh/2Ah
- Battery recharger 12/24V DC

#### 3.2 Receiver apparatus 6-12 channels

SUPPLY VOLTAGE	min 9 V, max 28 V
MAXIMUM CURRENT CONSUMPTION	370 mA a 10 V 563 mA a 28 V
MAXIMUM SWITCHABLE CURRENT	8 A
WORKING FREQUENCY	433,920 MHz
RF SENSITIVITY	- 100 dBm
PASS-BAND	600kHz a - 3dB
INTERFERENCE REJECTION	- 120 dB
RF EMISSION TO ANTENNA	- 80 dBm
IP PROTECTION (EN 60529)	The box and buttons assure IP65 protection level of the wrapping. The wiring is excluded: its protection level is assured by the installer
OUTPUTS	N° 12 MOSFET
CURRENT CARRYING CAPACITY	max 8 A
TEMPERATURA DI FUNZIONAMENTO	- 30 / + 80 °C

#### 3.2 Receiver apparatus 2-4 channels

SUPPLY VOLTAGE	min 9 V, max 28 V
MAXIMUM CURRENT CONSUMPTION	370 mA a 10 V 563 mA a 28 V
MAXIMUM SWITCHABLE CURRENT	8 A
WORKING FREQUENCY	433,920 MHz
RF SENSITIVITY	- 100 dBm
PASS-BAND	600kHz a - 3dB
INTERFERENCE REJECTION	- 120 dB
RF EMISSION TO ANTENNA	- 80 dBm
IP PROTECTION (EN 60529)	The box and buttons assure IP65 protection level of the wrapping. The wiring is excluded: its protection level is assured by the installer
REACTION TIME	2,5 seconds
OUTPUTS	N° 5 unstable relay type
CURRENT CARRYING CAPACITY	max 8 A
TEMPERATURA DI FUNZIONAMENTO	- 30 / + 80 °C

## 4. ELECTRICAL SPECIFICATIONS

### 4.1 Electrical specifications of the admissible load for 6-12 CH.

The output stage of radio remote controls uses unstable MOSFET.  
 The systems are sized for a **maximum load of 8 A inductive** simultaneously.  
 The MOSFET are sized to 16 A in any case, the mushroom-head emergency control, or from the transmitter, cuts off power to the outputs and thus ensures the absolute safety of the system.

### 4.1 Electrical specifications of the admissible load for 2-4 CH.

The output stage of radio remote controls uses unstable RELE'.  
 The systems are sized for a **maximum load of 8 A inductive** simultaneously.  
 The RELE' are sized to 16 A in any case, the mushroom-head emergency control, or from the transmitter, cuts off power to the outputs and thus ensures the absolute safety of the system.

### 4.2 Connecting devices to the receiver 6-12

A terminal board is used to connect devices (solenoid valves, remote switches) to the electronic board of the receiver.

In standard versions the radio remote controls are supplied with 1,50 m of cable. The cables used in the standard versions have a cross-section of 1 mm<sup>2</sup>, and the function/color pairing is as follows:

FUNCTION	CABLE
CE Motor/Valve	Blue
1	Blue1
2	Blue2
3	Blue3
4	Blue4
5	Blue5
6	Blue6
7	Blue7
8	Blue8

FUNCTION	CABLE
9	Blue9
10	Blue10
11	Blue11
12	Blue12
24	Yellow
36	Green
+12/24V	Red
-Earth	Yellow/Green

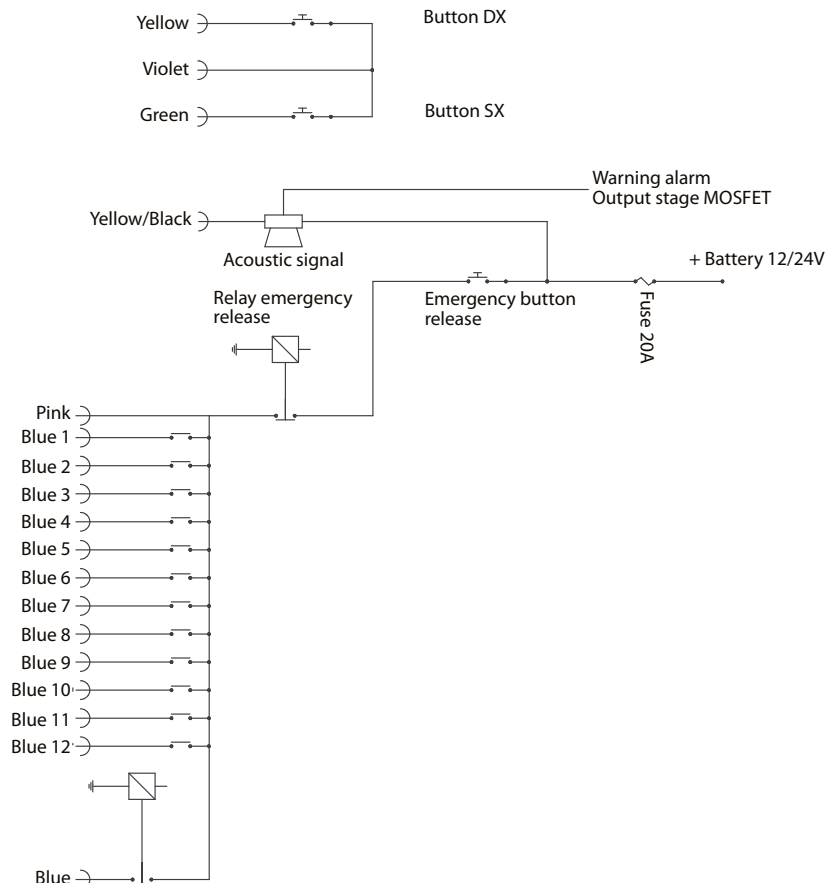

## 4. ELECTRICAL SPECIFICATIONS

### 4.2 Connecting devices to the receiver

A terminal board is used to connect devices (solenoid valves, remote switches) to the electronic board of the receiver.

In standard versions the radio remote controls are supplied with 1 m of cable, mounting two 5-pin connectors that are described in the next paragraph: the cables used in the standard versions have a cross-section of 1 mm<sup>2</sup>, and the function/color pairing is as follows:

POSITIVE POWER SUPPLY	"+"	Red
NEGATIVE POWER SUPPLY	"-"	Yellow/Green
UP 1	"UP1"	Black
DOWN 1	"DW1"	White
UP 2	"UP2"	Brown
DOWN 2	"DW2"	Purple
AUXILIARY	"AUX"	Light blue

### Output connectors

RADAR II 2-4 receiver	
<ul style="list-style-type: none"> <li>• 4 outputs to activate electrical devices (such as solenoid valves or relays), with a maximum absorption of 8 A each. The 4 outputs are enabled by the functions UP and DOWN of channel 1 and channel 2, respectively, and are not clean contacts, but reflect the supply voltage of the device (9 ÷ 28V);</li> </ul>	<p style="text-align: right;"><b>Plug 1</b></p>
<ul style="list-style-type: none"> <li>• 1 AUX output (see 4.3 for more information) with a maximum absorption of 8 A.</li> </ul>	<p style="text-align: right;"><b>Plug 2</b></p>

### 4.3 Setting the output type (single/Double-Acting)

The typical device configuration of OMFB radio remote controls is to control systems made up of electric pumps and solenoid valves.

The OMFB Quasar receiver is equipped with a series of 12 microswitches, shown in the figure: each microswitch allows the installer to set, for each individual output, the function as double-acting or single-acting, thus it allows the installer to define whether or not the AUX output must be enabled parallel with each individual output.

#### QUASAR 6-12 CH

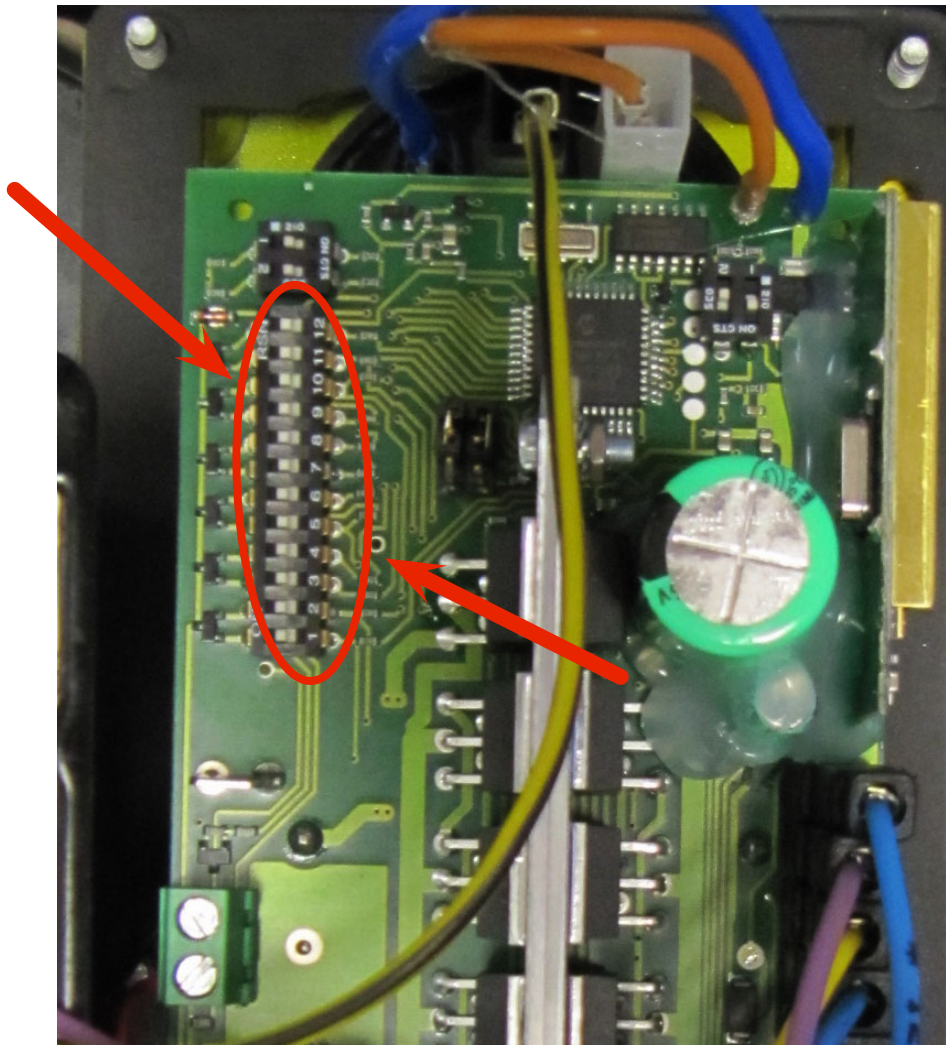

## 4. ELECTRICAL SPECIFICATIONS

### 4.3 Setting the output type (single/Double-Acting)

The typical device configuration of OMFB radio remote controls is to control systems made up of electric pumps and solenoid valves.

The OMFB Quasar receiver is equipped with a series of 10 microswitches, shown in the figure: 7-8-9-10 microswitchs allows the installer to set, for each individual output, the function as double-acting or single-acting, thus it allows the installer to define whether or not the AUX output must be enabled parallel with each individual output.

### QUASAR 2-4 CH

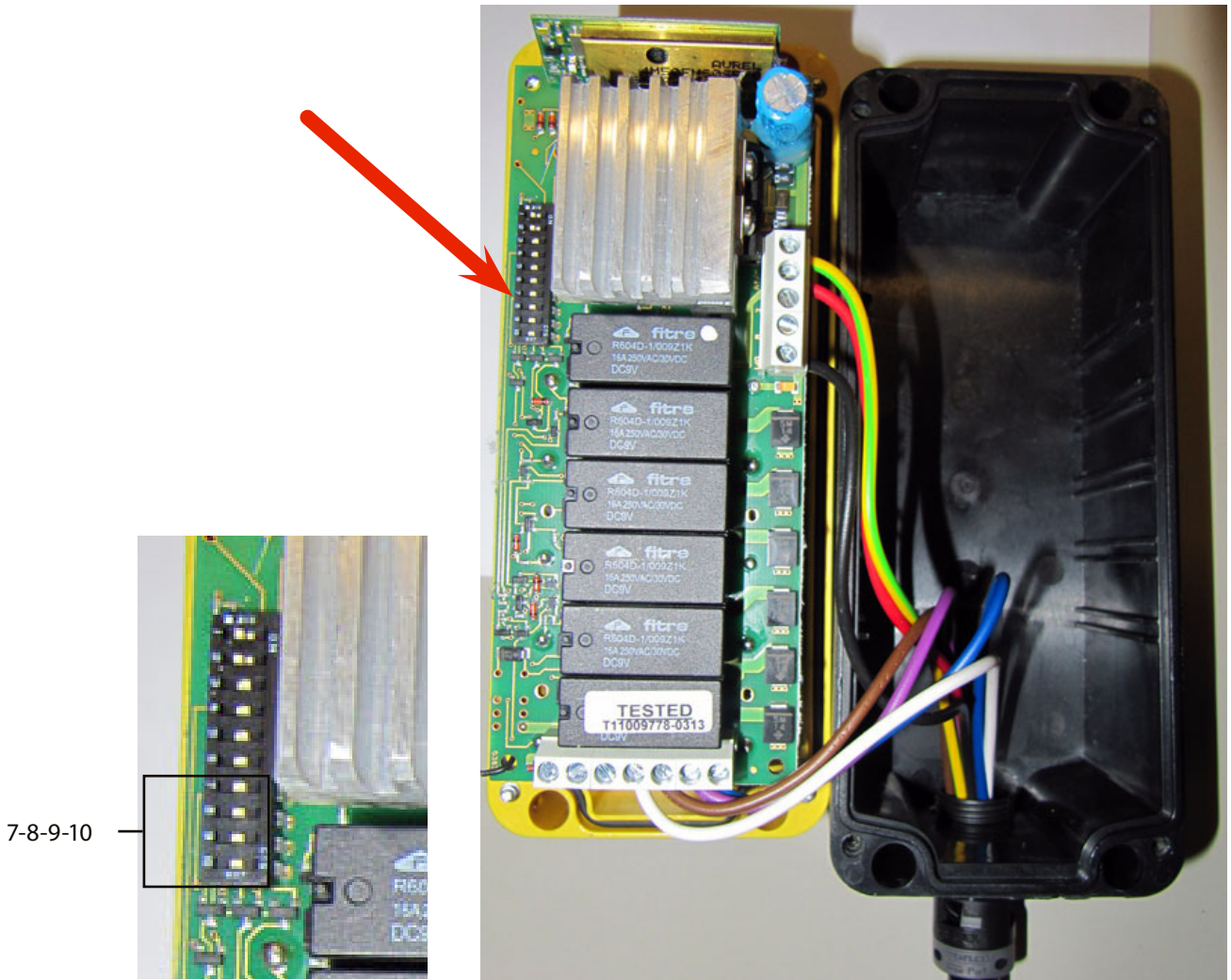

## 5. EMERGENCY STOP

### 5.1 Emergency stop engaged by the transmitter

The emergency stop command predominates over all other conditions, and thus may be activated even if the key for another transmitter function is inserted due to a breakdown or carelessness.

To deactivate the Emergency Stop function (signaled when the receiver status light goes on steady) and restore system operation, press the green Reset button.

### 5.1 Emergency stop engaged by the receiver

To activate the Emergency Stop function from the receiver press the mushroom-head STOP button.

6-12 CH - The receiver status light remains on steady, indicating receiver emergency status.

2-4 CH - The internal acoustic beeper produces a long steady sound.

To restore system operation, release the push-button by turning it clockwise and press the green Start button.

## 6. USING THE SYSTEM

### 6.1 Using the transmitter

When supplied, the transmitter has a minimum battery charge. Therefore, the battery must first be recharged for approximately 6 hours. This is done by connecting it to the universal 12V/24V battery charger supplied. The "Bat" light on the transmitter goes on, and remains on while the transmitter is being charged. It goes off when the unit is fully charged. To activate the transmitter, press the Start button and check that the "Bat" light blinks approximately once every 2 seconds, indicating that the transmitter is in Stand-by mode. If no function is activated, the transmitter turns off automatically after 30 seconds from the last use. Once the transmitter is ON, to activate the backlight, press the Start button and keep it pressed for 2 seconds. The backlight turns off temporarily when any function button is pressed, thus concentrating all available power on the radio emission and optimizing its use. To disable backlighting, press the Start button once more and keep it pressed for 2 seconds. Backlighting is also disabled when the transmitter turns off after being idle for 30 seconds. An increase in the Bat light blink rate (e.g. if the frequency is 1 blink or more a second) means that the batteries are low and need to be recharged. This is done by connecting the transmitter to the battery charger plugged into the vehicle 12V/24V outlet.

#### 6.1.1 Radiocontrols 14/24/36 channels - Special versions

(p/n 10105070047-10105070056-10105070092-10105070118-10105070183-10105070192)

For 24/36 channels radiocontrols, use the button numbered 24 (led 24/36 flashing) to activate outputs numbered from 13 to 24; use the button numbered 36 (led 24/36 with fixed light) to activate outputs numbered from 25 to 35. When led 24/36 is off, functions from 1 to 12 are active.

When led 24/36 is flashing or fixed, press button 24 or 36 in order to restore original configuration = functions 1 to 12 active).

For 14 channels radiocontrols, use the button numbered 24 to activate output numbered 13, use the button numbered 26 to activate output numbered 14.

## 6. USING THE SYSTEM

### 6.1.2 Special versions - 16 channel remote control (p/n 10105070234 -10105070243)

For the type of 16-channel remote control, press the on key to turn on the transmitter and use the outputs numbered from 1 to 8 by pressing the transmitter buttons from 1 to 8.

By pressing button 24 (LED 24/36 flashing), you can use the outputs numbered from 9 to 16 by keeping the buttons of transmitter from 1 to 8 pressed.

By pressing button 36 (LED 24/36 fixed), you can use the outputs numbered from 1 to 8 by always keeping the buttons of transmitter from 1 to 8 pressed.

With LED 24/36 off, the functions from 1 to 8 are active.

With LED 24/36 flashing or fixed to take the remote control back to the initial condition (functions active from 1 to 8), press key 24 or 36 respectively.

### 6.2 Programming procedure 6-12-16 CH FM:

**Normally the system is supplied pre-programmed. Therefore the following operations are only necessary when the transmitter needs to be replaced.** The programming procedure enables the receiver to recognize the transmitter code. To enter the system programming mode, press the green button on the receiver and keep it pressed for at least 10 seconds. The status light starts blinking, indicating that you have entered the receiver programming mode. Once the status light starts blinking, press the green button once more and keep it pressed for 5 seconds to reset any previously saved codes. In order to set a new TX once the receiver has been set in programming mode (the red light blinking), press the transmitter Start button and then press any of the function buttons. The light remains on steady for a few instants and then it goes off, indicating that the transmitter code has been acquired. Once the receiver has been set in programming mode, if it does not detect any valid code for more than 10 seconds, the system reverts to stand-by mode, keeping the current code.

Remote control 6-12 CH FM

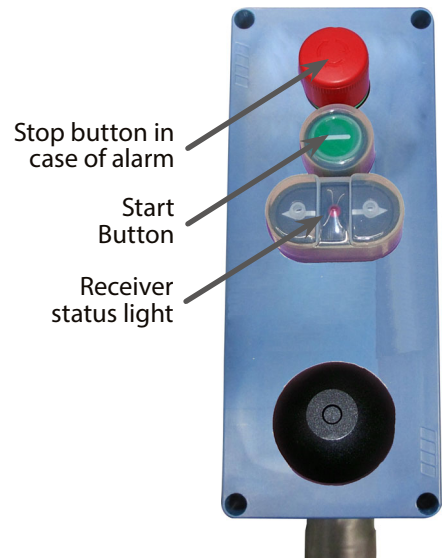

Remote control 16 CH FM



### 6.2 Programming procedure 2-4 CH FM:

**Normally the system is supplied pre-programmed. Therefore the following operations are only necessary when the transmitter needs to be replaced.** The programming procedure enables the receiver to recognize the transmitter code. To enter the system programming mode, press the green button on the receiver and keep it pressed for at least 10 seconds. The acoustic beeper starts beeping, indicating that you have entered the receiver programming mode. Once the beeper starts beeping, press the green button once more and keep it pressed for 5 seconds to reset any previously saved codes. In order to set a new TX once the receiver has been set in programming mode (beeping acoustic beeper), press the transmitter Start button and then press any of the function buttons. The acoustic beeper goes off, indicating that the transmitter code has been acquired. Once the receiver has been set in programming mode, if it does not detect any valid code for more than 10 seconds, the system reverts to stand-by mode, keeping the current code.

Start  
Button



### 6.3 Reset after emergency:

After a transmitter emergency, the reset can only be performed by pressing the green reset button on the receiver. The emergency mode is indicated with the receiver status light on steady. With the 2-4 ch versions the emergency status is confirmed by a long steady sound of the internal acoustic beeper.

### 6.4 Motor auxilliary

The Motor Auxiliary output is activated in parallel with each output signal if its Dip-Switch is set to ON. (see 4.3).



### **The Transmitter is not working, or works only at a short distance from the Receiver.**

Make sure that:

- The receiver power supply is correct both in terms of voltage (9 - 28 V) and polarity;
- The red emergency button of the receiver is not pressed, and that you have pressed the green reset button;
- The receiver is not installed in a metal housing;
- The LED on the transmitter lights when any of the commands is pressed. If not, make sure that the battery is present and charged, and replace it if necessary.
- The receiver has been programmed correctly. To be certain, repeat the steps described in the section PROGRAMMING PROCEDURES;
- The controlled devices function correctly if powered directly, cutting out the radio remote control, and if they have no short-circuits;

### **The Transmitter was dropped and now it doesn't work.**

Make sure that:

- The transmitter battery is still in its compartment;
- The battery connection is intact and ensures electrical contact;

### **IS IT POSSIBLE TO OBTAIN CLEAN CONTACTS IN PLACE OF THOSE THAT REFLECT THE SUPPLY VOLTAGE?**

No, you must use additional controlled relays at the supply voltage, and take the desired clean contact from these.

### **ONE OF THE LATEX SAFETY HOODS IS TORN.**

Send the receiver to OMFB SpA Hydraulic Components to replace and repair it, since the absence of these protections reduces the IP protection rating of the apparatus.

### **DOES THE QUASAR RADIO REMOTE CONTROL REQUIRE ANY MAINTENANCE?**

The **QUASAR** radio remote control requires no maintenance aside. However, it is recommended to keep the receiver clean, especially removing any deposits of mud or other material that could degrade its performance in the long run. Do not use hydraulic cleaners.

### **IS IT POSSIBLE TO INSERT THE RECEIVER INTO AN ADDITIONAL PLASTIC HOUSING?**

Yes, this is not subject to any particular limitations, as long as you are certain that the plastic of the housing into which the receiver is inserted has a minimal (or no) lead content.

If the problem persists, contact OMFB SpA Hydraulic Components.