

**KIT SUPPORTO DEVIATORI  
PNEUMATICI - DAF CF EURO-5  
BRACKET KIT FOR PNEUMATIC  
CONTROL SWITCH - DAF CF EURO-5**

**CODICE ORDINAZIONE  
ORDER CODE**

**10000240034**

Kit appositamente studiato per fissare i deviatori pneumatici sul supporto sedile del veicolo DAF CF EURO-5.  
Kit especially designed to mount pneumatic control switch on driver's seat of DAF CF EURO-5.

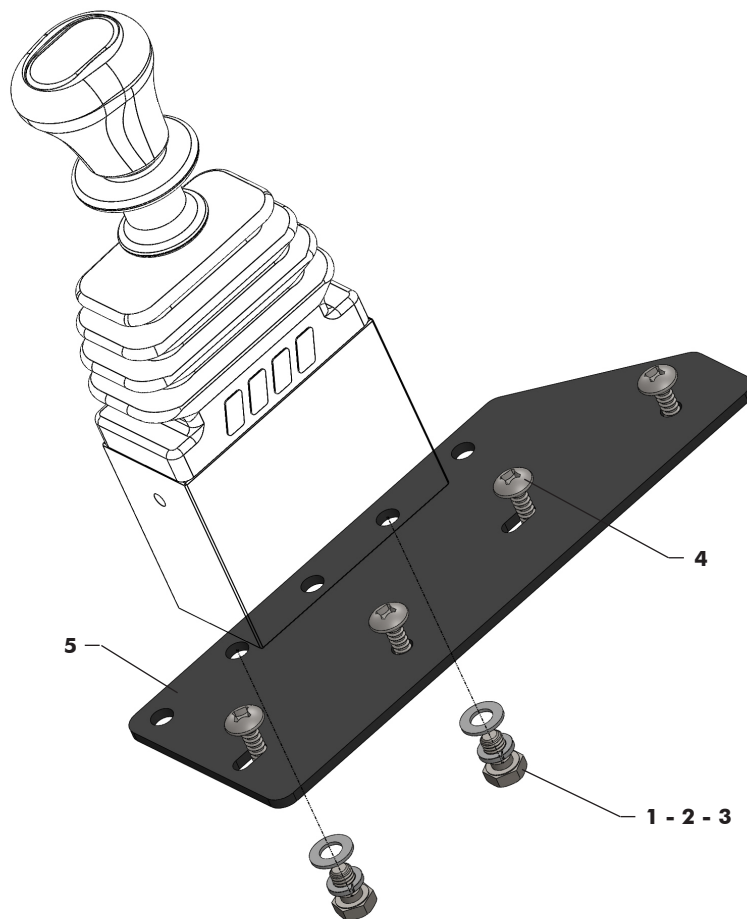

Data: Giovedì 05 dicembre 2013

Codice foglio: 99710002434 Rev: //

N°	Codice P. Number	Descrizione Description		Q.
1	50100700046	RONDELLA PIANA x M 6	WASHER x M 6	2
2	50100800036	RONDELLA ELASTICA x M 6 DIN 7980	WASHER x M 6 DIN 7980	2
3	50200200021	VITE TE M 6 x 12 UNI 5739	SCREW M6 x 12 UNI 5739	2
4	50201200127	VITE AUTOFILETTANTE 4,8 x 25 UNI 6954	SELF TAPPING SCREW 4,8 x 25 UNI 6954	4
5	53800401756	STAFFA MONTAGGIO DEVIATORE	BRACKET FOR AIR CONTROL	1



**SOLO PER DEVIATORI PNEUMATICI CON ATTACCHI LATERALI  
ONLY FOR PNEUMATIC CONTROL SWITCH WITH SIDE PORTS**

## ISTRUZIONI DI MONTAGGIO / MOUNTING INSTRUCTIONS



- 1 – Rimuovere il supporto originale della pulsantiera comando sospensioni.  
Remove the original support of suspension control unit.



- 2 – Rimuovere le due viti originali indicate in figura.  
Remove the two original screws as shown in the picture.



- 3 – Montare il deviatore pneumatico sulla piastra metallica (in una delle 3 posizioni consentite) utilizzando le 2 viti TE M6x12 e relative rondelle (2+2). Fissare quindi la piastra metallica con le 4 viti autofilettanti 4,8 x 25 fornite nel kit e come mostrato in figura. Collegare i tubi dell'aria.

*Install the pneumatic control switch onto the metal plate (in one of the three allowed positions) by using the 2 allen screws TE M6x12 with washers (2+2). Tight the air control onto the bracket by using the other 4 self tapping screws as shown in the picture. Connect the air pipe.*



**ATTENZIONE:** tutte le operazioni relative al montaggio, devono essere eseguite **IN SICUREZZA** secondo le norme vigenti.

**ATTENTION:** all the operations related to the assembling of these components have to be carried out in respect of the current **SAFETY** regulations in place

COMPANY WITH  
QUALITY SYSTEM  
CERTIFIED BY DNV GL  
= ISO 9001 =

pag.2

O.M.F.B. S.p.A. Hydraulic Components  
We reserve the right to make any changes without notice.  
Edition 2013.12 No reproduction, however partial, is permitted.  
Via Cave, 7/9 25050 Provaglio d'Iseo (Brescia) Italy Tel.: +39.030.9830611  
Fax: +39.030.9839207-208 Internet:www.omfb.it e-mail:info@omfb.it

**OMFB**  
HYDRAULIC COMPONENTS