

SUPPORTO INCLINATO N-FORCE + STAFFA PER SCANIA ANGLED BRACKET FOR N-FORCE AIR CONTROL C/W PLATE FOR SCANIA

CODICE
CODE

10000270467

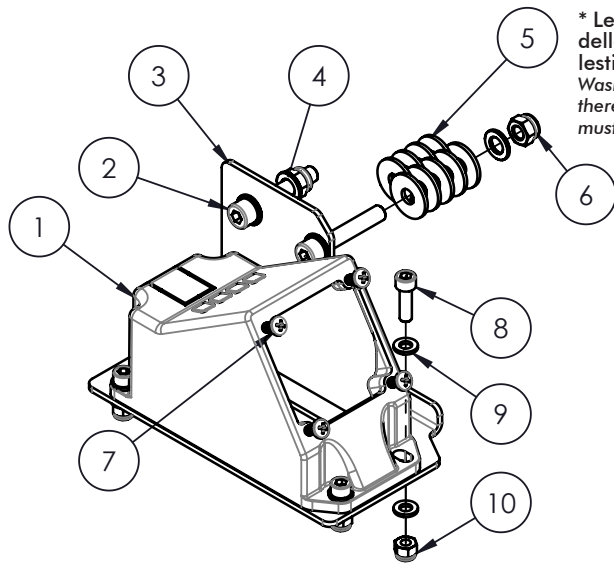

* Le rondelle servono per il pareggio dello spessore, per cui si valuti in al-
lestimento il numero ideale.
Washers are used to equalize thickness
therefore the necessary quantity to be used
must be evaluated during installation.

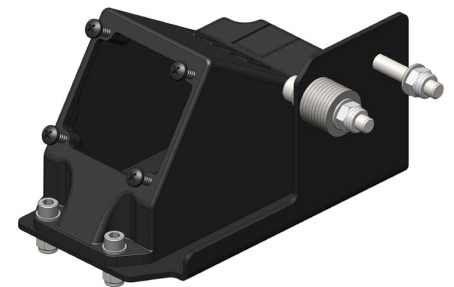

Pos.	Codice Code	Descrizione	Description	Q.
1	50900001180	Supporto plastica inclinato	Angled plastic bracket	1
2	50200300600	Vite TCE UNI 5931 M8	Screw TCE UNI 5931 M8	2
3	53800403665	Supporto N-FORCE Scania	Bracket N-FORCE Scania	1
4	50100700064	Rondella piana x M8	Washer x M8	4
5*	50100700251	Rondella piana x M8	Washer x M8	9
6	50501000034	Dado autobloccante x M8	Self-blocking nut M8	2
7	50201200127	Vite 4,8x25 ISO 7049	Screw 4,8x25 ISO 7049	4
8	50200200450	Vite TCE M6	Screw TCE M6	4
9	50100700046	Rondella piana x M6	Washer x M6	8
10	50501000016	Dado autobloccante x M6	Self-blocking nut M6	4

Data: Mercoledì 16 settembre 2020

Codice foglio:99710000356 Rev: //

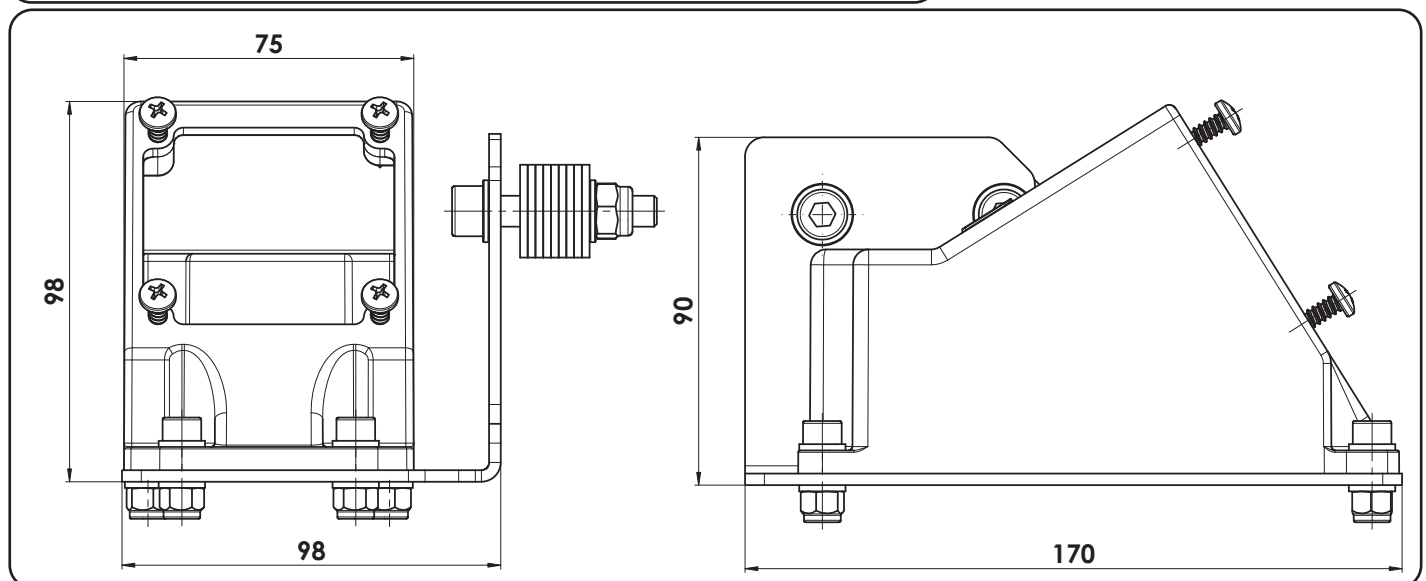

ATTENZIONE: tutte le operazioni relative al montaggio, devono essere eseguite **IN SICUREZZA** secondo le norme vigenti.
ATTENTION: all the operations related to the assembling of these components have to be carried out in respect of the current **SAFETY** regulations in place



pag.1

OMFB

HYDRAULIC COMPONENTS

O.M.F.B. S.p.A. Hydraulic Components

We reserve the right to make any changes without notice.

Edition 2020.09 No reproduction, however partial, is permitted.

Via Cave, 7/9 25050 Provaglia d'Iseo (Brescia) Italy Tel.: +39.030.9830611
Fax: +39.030.9839207-208 Internet:www.omfb.it e-mail:info@omfb.it

COMPANY WITH
QUALITY SYSTEM
CERTIFIED BY DNV GL
= ISO 9001:2015 =