

**KIT SUPPORTO N-FORCE EVO  
PER MAN TGX-TGS CABINA ALTA E BASSA  
BRACKET KIT FOR N-FORCE EVO AIR CONTROL  
TO SUIT MAN TGX/TGS LOW AND HIGH CABIN**

**CODICE  
CODE**

**10000270289**

Kit appositamente studiato per fissare i deviatori pneumatici serie N-Force EVO a fianco del sedile sui veicoli MAN TGX e TGS cabina alta e bassa.

*Kit especially designed for mounting the air controls series N\_FORCE EVO next to driver's seat for MAX TGX and TGS low and high cabin trucks.*

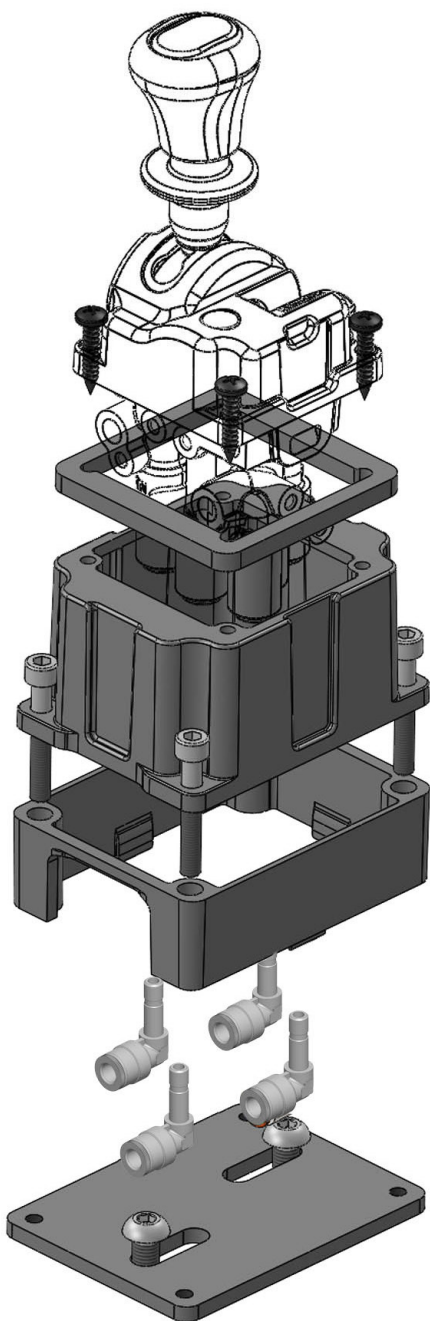

**MONTAGGIO ULTIMATO  
SU CABINA BASSA  
ASSEMBLING COMPLETED  
ON LOW CABIN**



Data: Lunedì 03 ottobre 2016

Codice foglio: 99710000289 Rev: AA



**ATTENZIONE:** tutte le operazioni relative al montaggio, devono essere eseguite **IN SICUREZZA** secondo le norme vigenti.

**ATTENTION:** all the operations related to the assembling of these components have to be carried out in respect of the current **SAFETY** regulations in place



Rimuovere la plastica indicata con la freccia a fianco del sedile.  
Remove the plastic part indicated by the arrow on the side of the seat.



Eliminare il supporto indicato.  
Disregard the indicated support.

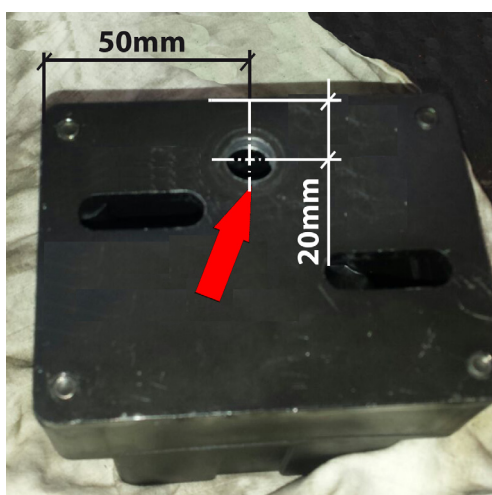

Fare un foro  $\varnothing 10$  sul fondo del nostro supporto come indicato.  
Posizionare il supporto stesso e fare un segno sulla lamiera sottostante  
in corrispondenza del foro appena eseguito.  
Drill a  $\varnothing 10$  hole on the bottom of our bracket as shown.  
Place the bracket and mark the hole just drilled on the metal sheet below.



Nel foro sulla lamiera, inserire un inserto filettato da M6x1. Rimontare quindi il supporto di plastica completo ed avvitarlo.  
*In the hole on the metal sheet place an M6x1 insert. Remount the complete bracket and tighten it.*



Collegare i tubi dell'aria e montare il comando in posizione.  
*Connect the air pipes and mount the air control in its position.*

Far passare i tubi dell'aria. Risistemare la copertura e rimettere la plastica a lato sedile. Fare un'apertura seguendo il profilo del supporto in plastica sottostante.  
*Slide through the air pipes. Re-fit the cover and plastic on the side of the seat. Make an opening following the profile of the plastic support below.*



## MONTAGGIO ULTIMATO SU CABINA ALTA ASSEMBLING COMPLETED ON HIGH CABIN

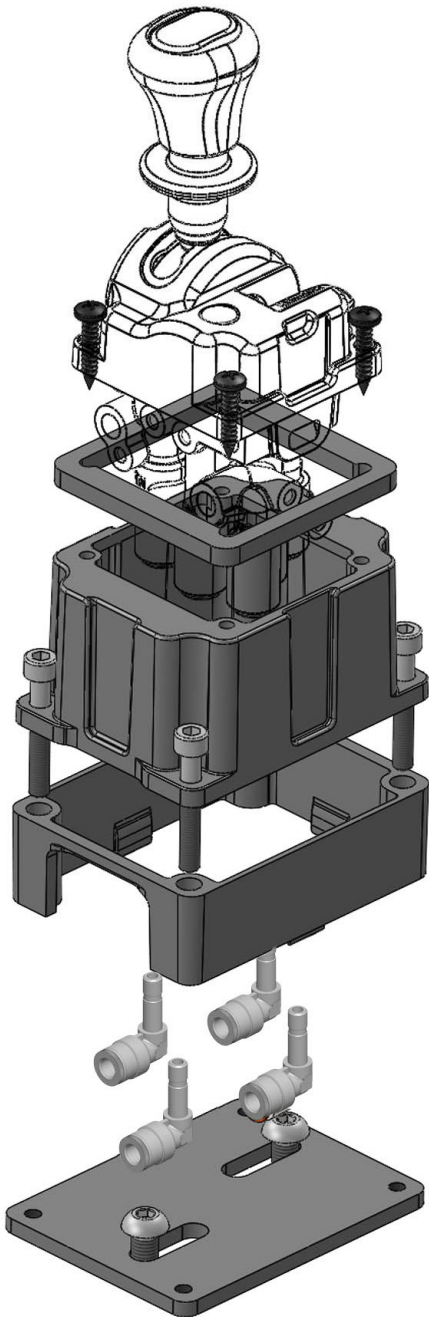

### MONTAGGIO / MOUNTING

Rimuovere il vano portaoggetti in plastica svitando le due viti di fissaggio, forare nella posizione indicata per far passare i tubi dell'aria per l'impianto.

Remove the coin plastic holder undoing the two fixing screws; drill into the given position and display the air pipes.



Fissare la piastra di supporto all'interno del vano portaoggetti utilizzando le due viti M 8x35 a testa ribassata, fissare il supporto in plastica alla piastra con le 4 viti a brugola M 6 x 40.

Montare il deviatore pneumatico utilizzando i raccordi pneumatici a 90° e le viti autofilettanti inclusi nel kit.

Fix the bracket plate inside the plastic holder by using the two M8x35 low-head screws and then fix the plastic holder to the plate by using the 4 Allen screws M6x40.

Assembly the air control by using 90° elbow air fittings and self-locking screws included in the kit.



**ATTENZIONE:** tutte le operazioni relative al montaggio, devono essere eseguite **IN SICUREZZA** secondo le norme vigenti.

**ATTENTION:** all the operations related to the assembling of these components have to be carried out in respect of the current **SAFETY** regulations in place