

**SUPPORTO INCLINATO - 2^a serie - N-FORCE
PER SCANIA E6 SERIE R-S**

**(Trattore a 2 assi - supporto sedile chiuso)
Bracket kit - 2nd series - for N-FORCE installation
on SCANIA E6 R-S Series
(2-axes Tractor - driver seat with closed bottom cover)**

**CODICE ORDINAZIONE
ORDER CODE**

10000270378

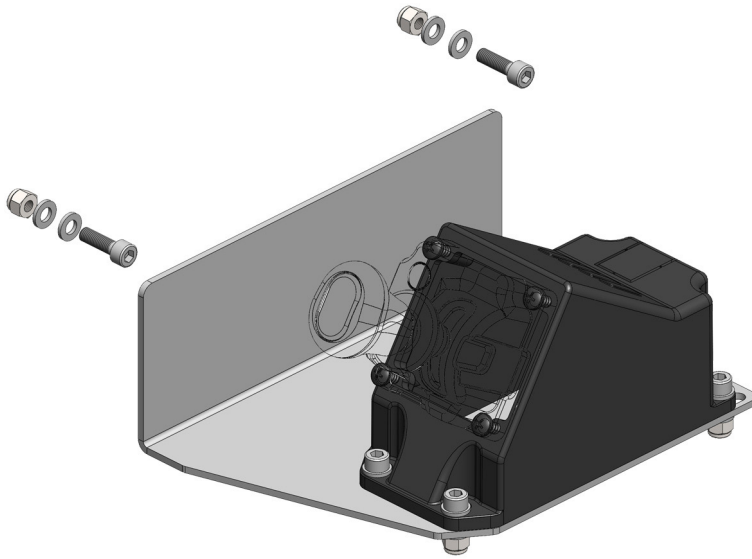

Kit appositamente studiato per fissare i deviatori pneumatici serie N-FORCE sul supporto sedile del veicolo SCANIA EURO 6 - 2^a serie.

Assembly kit especially designed to mount air controls series N-FORCE on the bracket driver's seat of SCANIA EURO 6 - 2nd series.

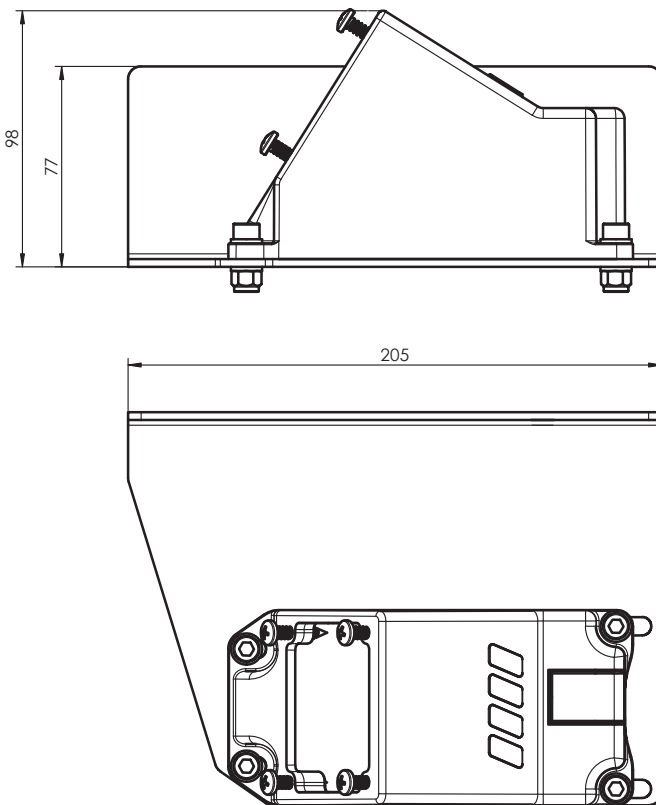

Data: Mercoledì 4 aprile 2018

Codice foglio:99710000278 Rev: //



ATTENZIONE: tutte le operazioni relative al montaggio, devono essere eseguite **IN SICUREZZA** secondo le norme vigenti.

ATTENTION: all the operations related to the assembling of these components have to be carried out in respect of the current **SAFETY** regulations in place

pag.1

O.M.F.B. S.p.A. Hydraulic Components

We reserve the right to make any changes without notice.

Edition 2018.04 No reproduction, however partial, is permitted.

Via Cave, 7/9 25050 Provaglio d'Iseo (Brescia) Italy Tel.: +39.030.9830611

Fax: +39.030.9839207-208 Internet:www.omfb.it e-mail:contatti@omfb.it

**COMPANY WITH
QUALITY SYSTEM
CERTIFIED BY DNV GL
= ISO 9001:2015 =**

OMFB

HYDRAULIC COMPONENTS

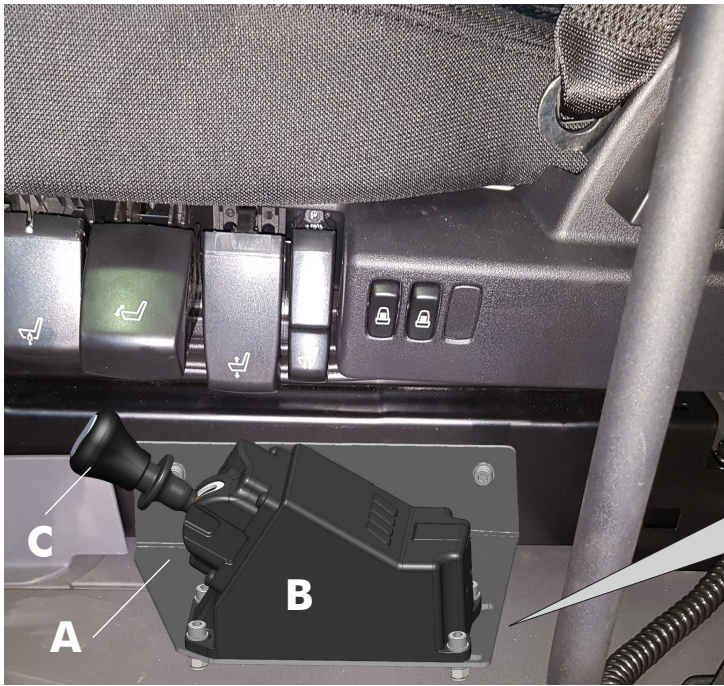

- 1 - Montare la piastra **A** al sedile. Montare il supporto **B** sulla piastra **A**. Collegare i tubi dell'aria al deviatore pneumatico N-FORCE **C** e fissarlo al supporto **B** con le 4 viti autofilettanti.
- 1 - Mount the plate **A** to driver's seat. Mount the bracket **B** on plate **A**. Connect the air pipe into the air control N-FORCE **C** and fix it on the bracket **B** by using the 4 self-tapping screws.



In caso di impossibilità o difficoltà di utilizzo o realizzo di fori filettati sul supporto del sedile, è consigliato l'uso degli inserti filettati inclusi nella confezione. Per il montaggio degli stessi è necessario realizzare fori con punta Ø9 ed utilizzare l'apposito attrezzo di montaggio.
In case of difficulties while making or using the threaded holes on the seat's support, it is recommended to use the inserts included in the package. For mounting these inserts it is necessary to drill holes Ø9 and using the specifying mounting tool.

pag.2