

KIT SUPPORTO N-FORCE/KIP-AIR PER MAN TGX-TGS

CODICE
CODE

10000270234

BRACKET KIT FOR N-FORCE/KIP-AIR
CONTROL FOR MAN TGX-TGS CABINS

Kit appositamente studiato per fissare i deviatori pneumatici serie N-Force / Kip-Air a fianco del sedile sui veicoli MAN TGX e TGS.

Kit especially designed for mounting the air controls series N-FORCE and KIP-AIR next to driver's seat for MAX TGX and TGS trucks.

ISTRUZIONI MONTAGGIO MOUNTING INSTRUCTIONS

Rimuovere il vano portaoggetti in plastica svitando le due viti di fissaggio, forare nella posizione indicata e far passare i tubi dell'aria per l'impianto.

Remove the coin plastic holder undoing the two fixing screws; drill into the given position and display the air pipes.

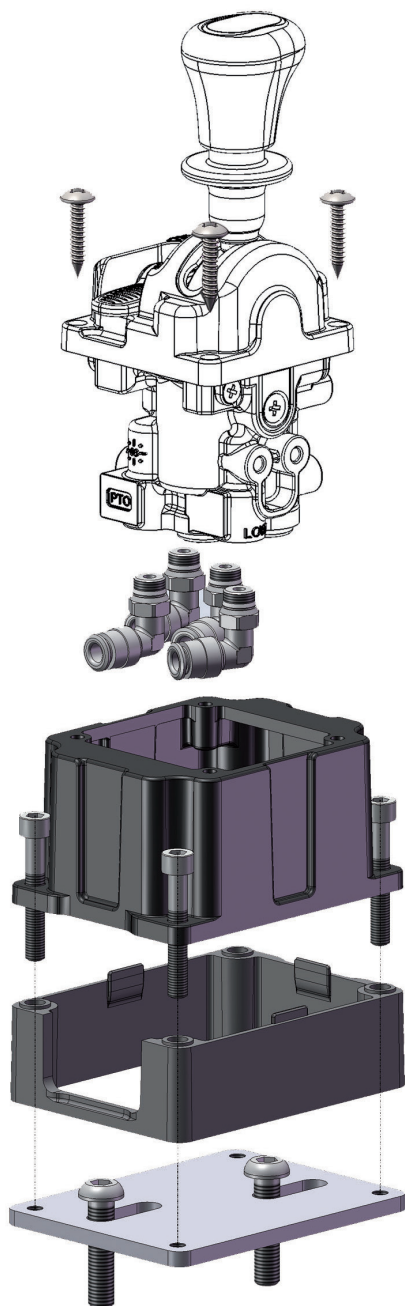

Fissare la piastra di supporto all'interno del vano portaoggetti utilizzando le due viti M 8x35 a testa ribassata, fissare il supporto in plastica alla piastra con le 4 viti a brugola M 6 x 40. Montare il deviatore pneumatico utilizzando i raccordi pneumatici a 90° e le viti autofilettanti inclusi nel kit.

Fix the bracket plate inside the plastic holder by using the two M8x35 low-head screws and then fix the plastic holder to the plate by using the 4 Allen screws M6x40. Assembly the air control by using 90° elbow air fittings and self-locking screws included in the kit.



ATTENZIONE: tutte le operazioni relative al montaggio, devono essere eseguite **IN SICUREZZA** secondo le norme vigenti.

ATTENTION: all the operations related to the assembling of these components have to be carried out in respect of the current **SAFETY** regulations in place

Data: Giovedì 08 giugno 2012

Codice foglio: 99710000234 Rev: //

pag.1

O.M.F.B. S.p.A. Hydraulic Components

We reserve the right to make any changes without notice.

Edition 2012.06 No reproduction, however partial, is permitted.

Via Cave, 7/9 25050 Provaglio d'Iseo (Brescia) Italy Tel.: +39.030.9830611
Fax: +39.030.9839207-208 Internet:www.omfb.it e-mail:contatti@omfb.it

COMPANY WITH
QUALITY SYSTEM
CERTIFIED BY DNV GL
= ISO 9001:2015 =