

SUPPORTO INCLINATO N-FORCE + STAFFA PER DAF XF 2016/04

CODICE ORDINAZIONE
ORDER CODE

10000270332

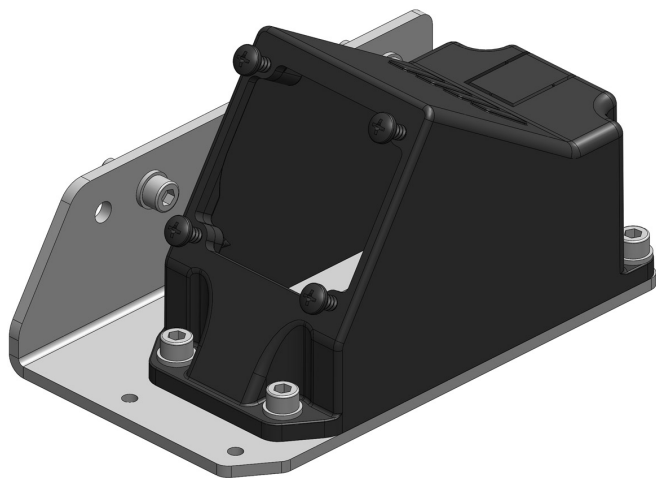

Kit appositamente studiato per fissare i deviatori pneumatici serie N-FORCE sul supporto sedile del veicolo DAF XF 2016/04.

Kit especially designed to mount air controls type N-FORCE on driver's seat of DAF XF 2016/04.

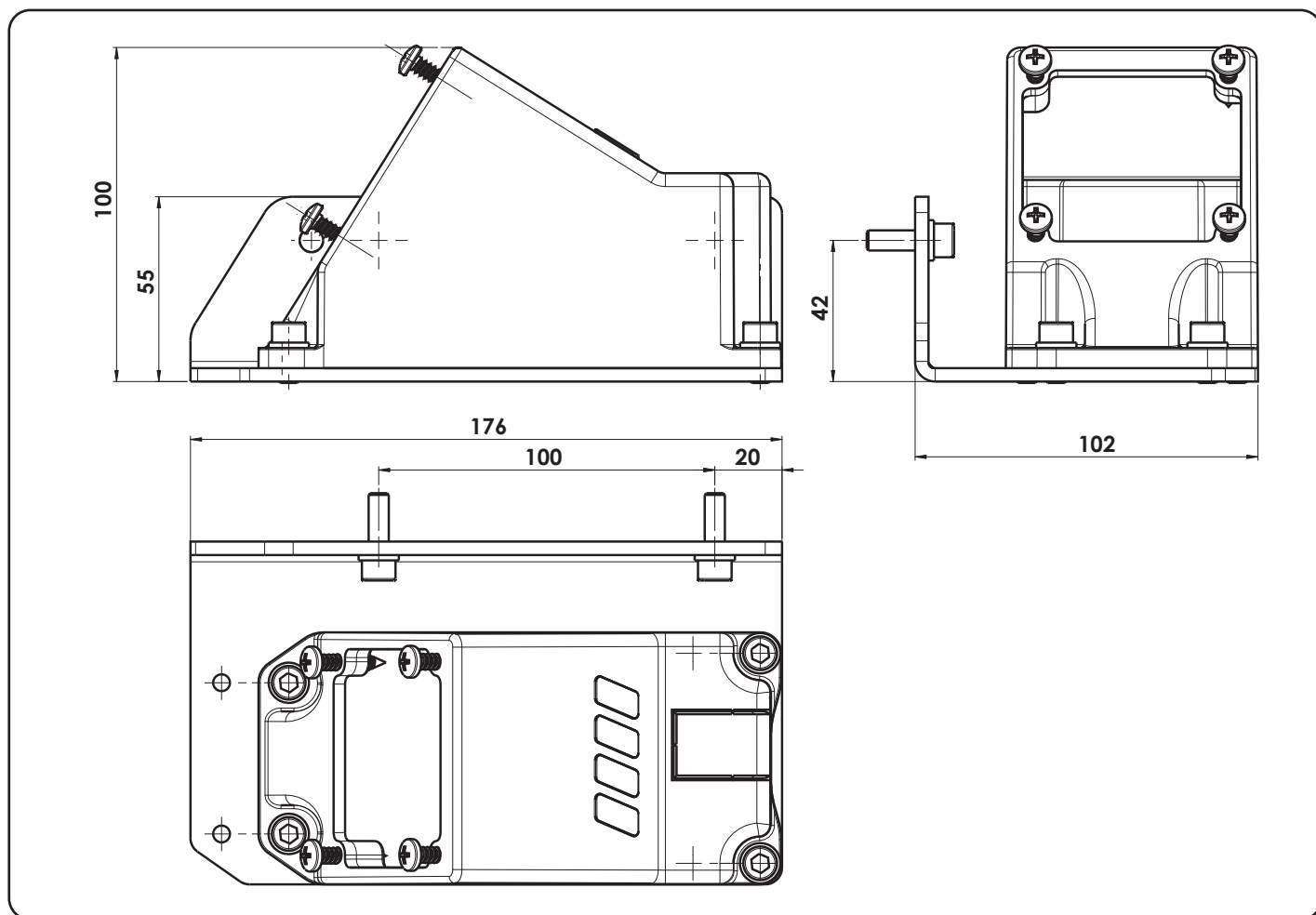

Data: Lunedì 02 gennaio 2017

Codice foglio: 99710000232 Rev: AA



ATTENZIONE: tutte le operazioni relative al montaggio, devono essere eseguite **IN SICUREZZA** secondo le norme vigenti.

ATTENTION: all the operations related to the assembling of these components have to be carried out in respect of the current **SAFETY** regulations in place

pag.1

O.M.F.B. S.p.A. Hydraulic Components

We reserve the right to make any changes without notice.

Edition 2016.11 No reproduction, however partial, is permitted.

Via Cave, 7/9 25050 Provaglia d'Iseo (Brescia) Italy Tel.: +39.030.9830611
Fax: +39.030.9839207-208 Internet: www.omfb.it e-mail: info@omfb.it

COMPANY WITH
QUALITY SYSTEM
CERTIFIED BY DNV GL
= ISO 9001:2015 =

ISTRUZIONI DI MONTAGGIO / MOUNTING INSTRUCTIONS

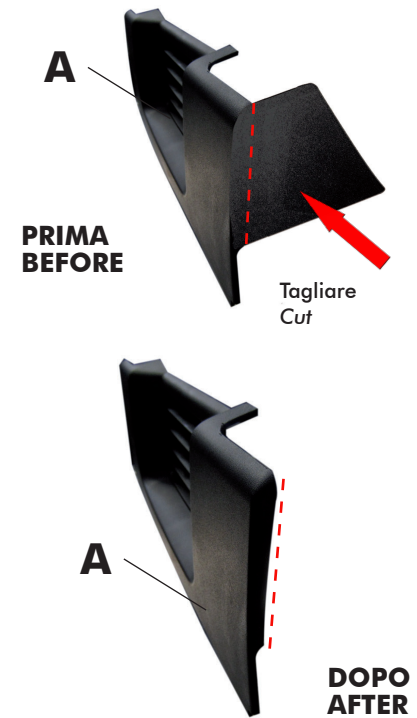
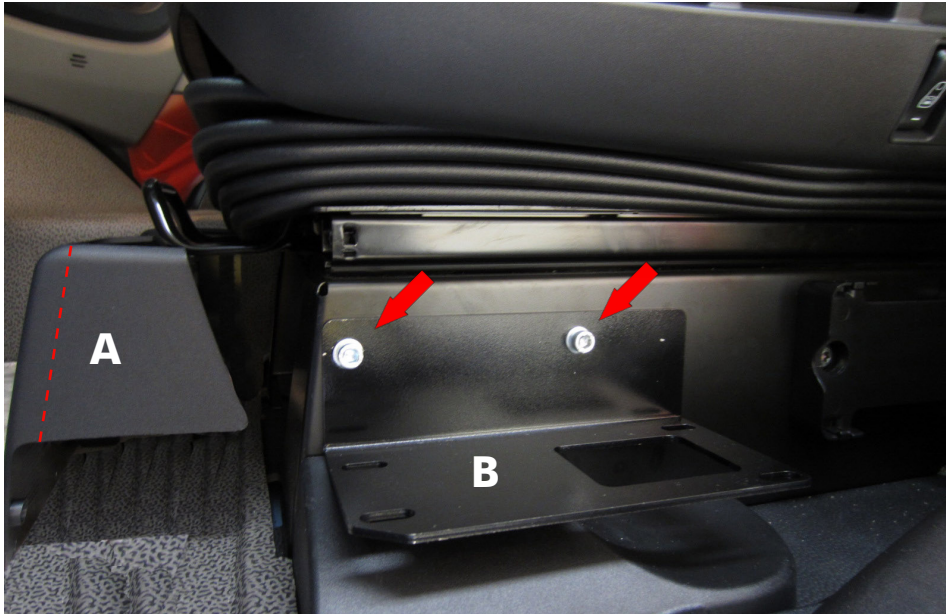

1 - Rimuovere il particolare **A** e tagliare la plastica come indicato in figura.
Nei 2 fori filettati M6 presenti nel sedile, fissare la piastra **B**.

1 - Remove the part **A** and cut the plastic part as shown in the picture. Insert the bracket **B** into the two threaded holes M6.



No vite
No screw

2 - Montare il supporto **C** sulla piastra **B** con 3 viti M6.

Collegare i tubi dell'aria al deviatore pneumatico N-FORCE **D** e fissarlo al supporto **C** con le 4 viti autofilettanti.

2 - Mount the bracket **C** on the plate **B** by using the 3 screws M6. Connect the air pipe into the air control N-FORCE **D** and fix it on the bracket **C** by using the 4 self-tapping screws.



In caso di impossibilità o difficoltà di utilizzo o realizzo di fori filettati sul supporto del sedile, è consigliato l'uso degli inserti filettati inclusi nella confezione. Per il montaggio degli stessi è necessario realizzare fori con punta Ø9 ed utilizzare l'apposito attrezzo di montaggio.

In case of difficulties while making or using the threaded holes on the seat's support, it is recommended to use the inserts included in the package. For mounting these inserts it is necessary to drill holes Ø9 and using the specifying mounting tool.

pag.2

COMPANY WITH
QUALITY SYSTEM
CERTIFIED BY DNV GL
= ISO 9001:2015 =

O.M.F.B. S.p.A. Hydraulic Components
We reserve the right to make any changes without notice.
Edition 2016.11 No reproduction, however partial, is permitted.
Via Cave, 7/9 25050 Provaglio d'Iseo (Brescia) Italy Tel.: +39.030.9830611
Fax: +39.030.9839207-208 Internet:www.omfb.it e-mail:info@omfb.it

