

**KIT DI MONTAGGIO
PER CAMBI
ZF ECOMID 9S... 16S...**
**MOUNTING KIT FOR ZF ECOMID
9S... 16S... GEARBOX**

CODICE KIT
KIT CODE **09703610020**

CODICE PTO
PTO CODE **010036**

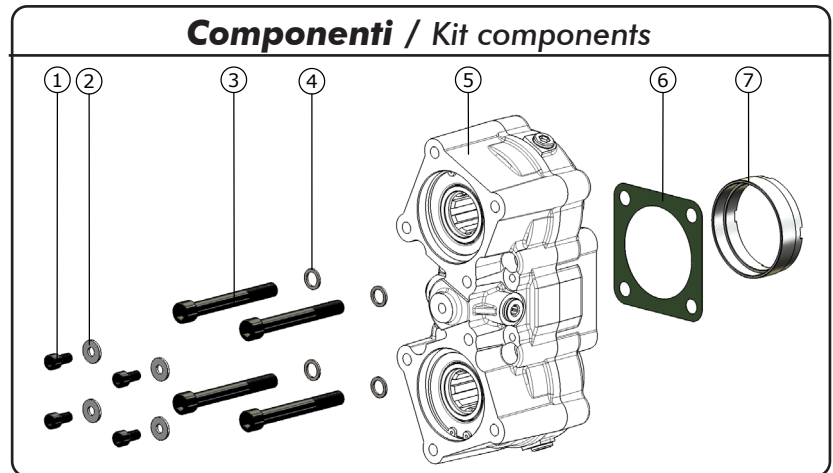
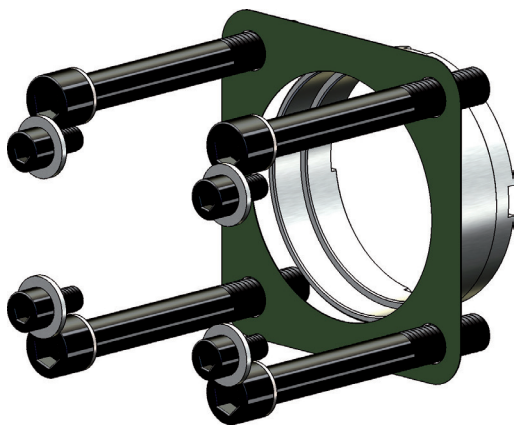

Pos.	Codice / Code	Qt.	Descrizione / Description	
1	50200300520	4	Vite TCE M 8x14	Screw TCE M 8x14
2	50100710080	4	Rondella piana	Flat washer
3	50200500715	4	Vite TCE M 12x100	Screw TCE M 12x100
4	50102500124	4	Rondella acciaio	Steel washer
5	010036	1	PTO - non inclusa nel kit	PTO-not included in the kit
6	50700100086	1	Guarnizione finestra	Window gasket
7	53400200391	1	Anello 75x85	Ring 75x85



In fase di montaggio sul cambio, eliminare l'anello \varnothing esterno 80 - spessore 29, contenuto nel kit albero 93-6-..... Utilizzare l'anello contenuto in questo kit 09703610020.

While fitting, please disregard the ring having external \varnothing 80mm - thickness 29, included in the quill-shaft 093006-..... Please use the ring included in the present kit 09703610020.

Spazio disponibile per applicazioni / Prop shaft clearance

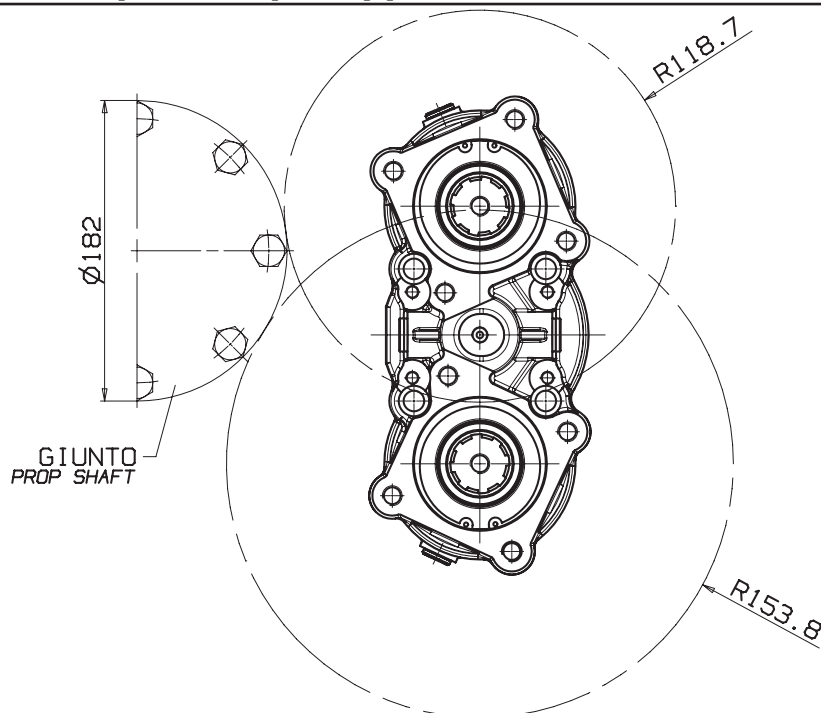

pag.1