

KIT DI MONTAGGIO PER CAMBI ZF ECOLITE MOUNTING KIT FOR ZF ECOLITE GEARBOXES

CODICE KIT
KIT CODE

97-30-10017

CODICE PTO
PTO CODE

12-30

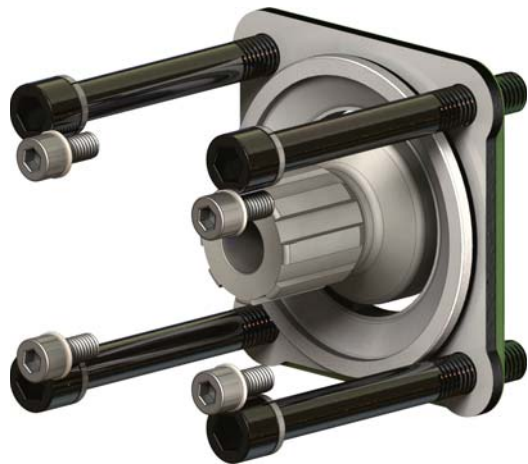

Componenti / Kit components

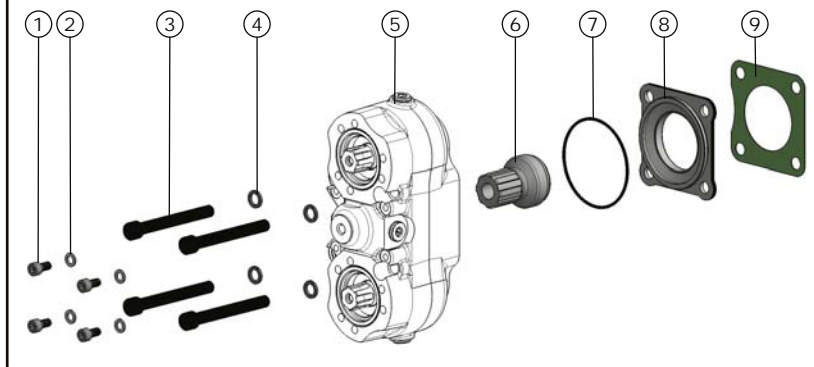

Pos.	Codice / Code	Qt.	Descrizione / Description	
1	502-003-00520	4	Vite TCE M 8x14	Screw TCE M 8x14
2	501-007-00279	4	Rondella piana	Flat washer
3	502-005-01054	4	Vite TCE M 12x105	Screw TCE M 12x105
4	501-008-00063	4	Rondella elastica	Steel washer
5	012-030	1	PTO - non inclusa nel kit	PTO-not included in the kit
6	525-002-00327	1	Ingranaggio spostabile	Sliding gear
7	506-006-03350	1	Guarnizione OR	O-Ring
8	528-007-00748	1	Flangia	Flange
9	507-001-00077	1	Guarnizione finestra	Window gasket

Spazio disponibile per applicazioni / Prop shaft clearance

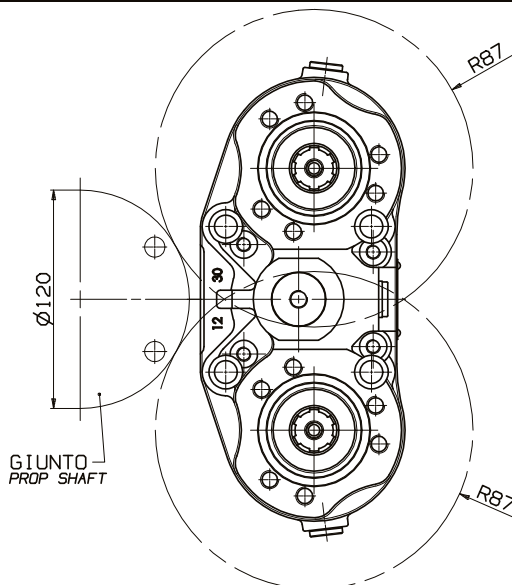

pag.7