

# KIT DI MONTAGGIO PER CAMBI ZF ECOSPLIT - ZF AS TRONIC

**CODICE KIT**  
KIT CODE

**97-36-10011**

**MOUNTING KIT FOR ZF ECOSPLIT -  
ZF ASTRONIC GEARBOX**

**CODICE PTO**  
PTO CODE

**10-36**

Codice fascicolo: 997-400-01036

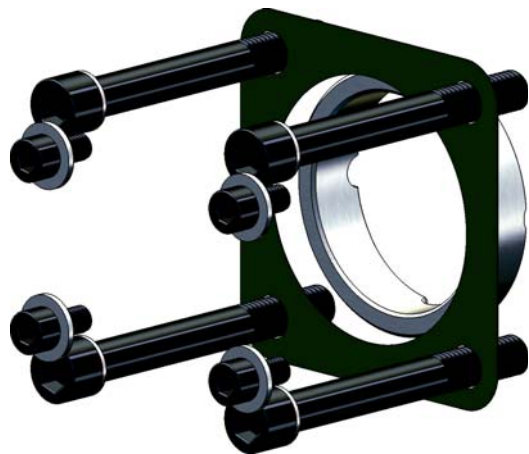

## Componenti / Kit components

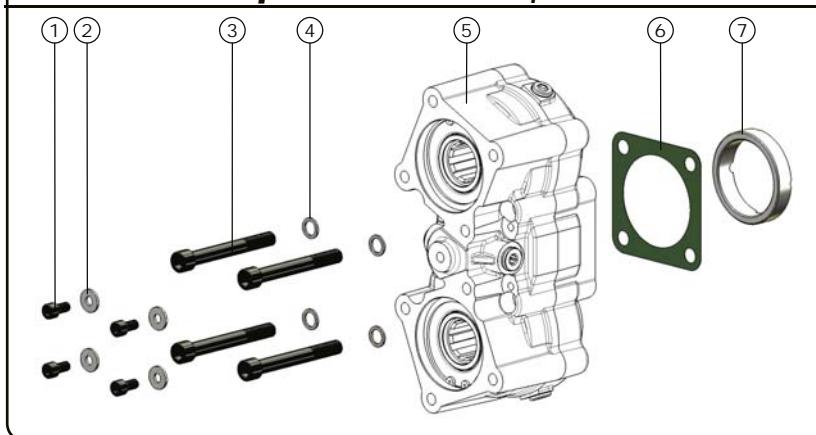

Pos.	Codice / Code	Qt.	Descrizione / Description	
1	502-003-00520	4	Vite TCE M 8x14	Screw TCE M 8x14
2	501-007-10080	4	Rondella piana	Flat washer
3	502-005-00715	4	Vite TCE M 12x100	Screw TCE M 12x100
4	501-025-00124	4	Rondella acciaio	Steel washer
5	010-036	1	PTO - non inclusa nel kit	PTO-not included in the kit
6	507-001-00086	1	Guarnizione finestra	Window gasket
7	534-002-00382	1	Anello 66x80	Ring 66x80



In fase di montaggio sul cambio, eliminare l'anello  $\varnothing$  esterno 80 - spessore 29, contenuto nel kit albero 93-6-17 e 93-6-53. Utilizzare l'anello contenuto in questo kit 97-36-10011.  
While fitting, please disregard the ring having external  $\varnothing$  80mm - thickness 29, included in the quill-shaft 09300600017 and 09300600053. Please use the ring included in the present kit 09703610011.

## Spazio disponibile per applicazioni / Prop shaft clearance

**ZF Ecosplit**

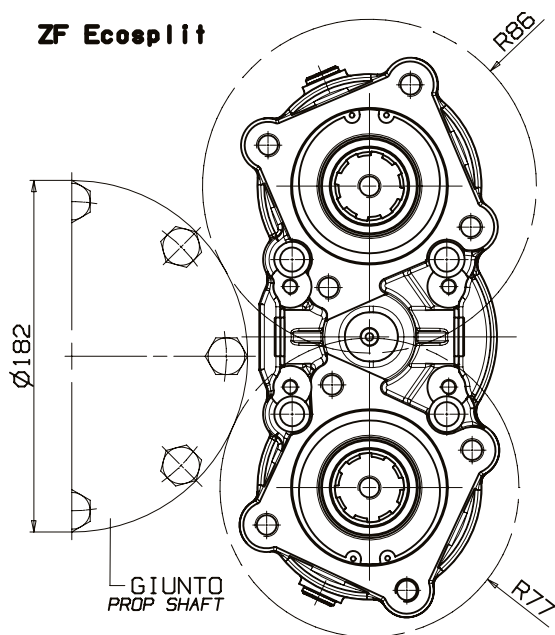

**ZF Astronic**

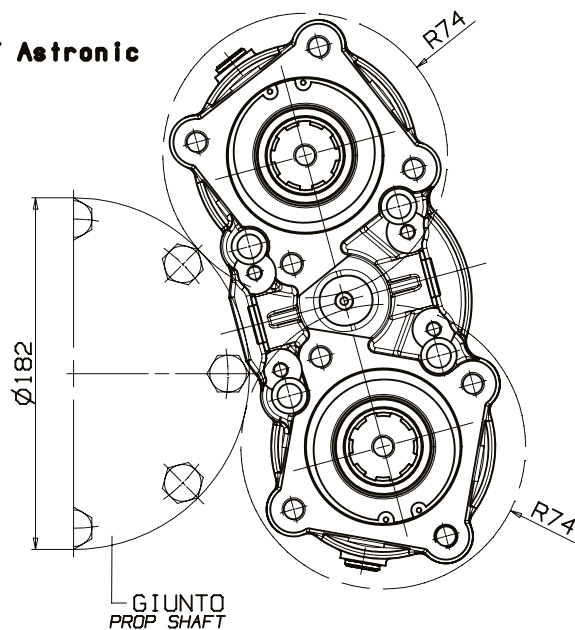

Data: Venerdì 24 febbraio 2012

Codice foglio: 997-097-10011 Rev:AA

pag.5

**OMFB**  
HYDRAULIC COMPONENTS

O.M.F.B. S.p.A. Hydraulic Components  
We reserve the right to make any changes without notice.  
Edition 2008.09 No reproduction, however partial, is permitted.  
Via Cave, 7/9 25050 Provaglio d'Iseo (Brescia) Italy Tel.: +39.030.9830611  
Fax: +39.030.9839207-208 Internet:www.omfb.it e-mail:info@omfb.it

COMPANY WITH  
QUALITY SYSTEM  
CERTIFIED BY DNV GL  
= ISO 9001 =