

ALBERO DI CORREDO CON LUBRIFICA QUILL SHAFT WITH LUBRICATION

CODICE
CODE

093916

Detroit DT12 OD-OC-DC
Mercedes G291-12, G340-12
Mercedes G291-12+Voith, G340-12+Voith

LUBRIFICA INTERNA
INTERNAL LUBRICATION
STANDARD

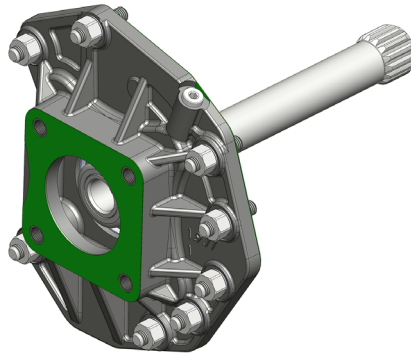

LUBRIFICA ESTERNA
EXTERNAL LUBRICATION

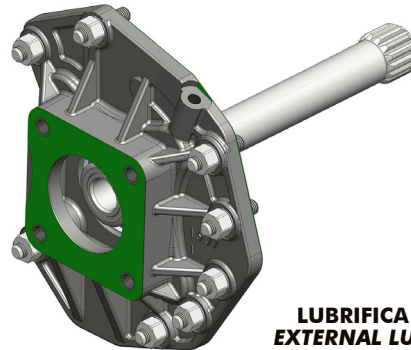

99740009310

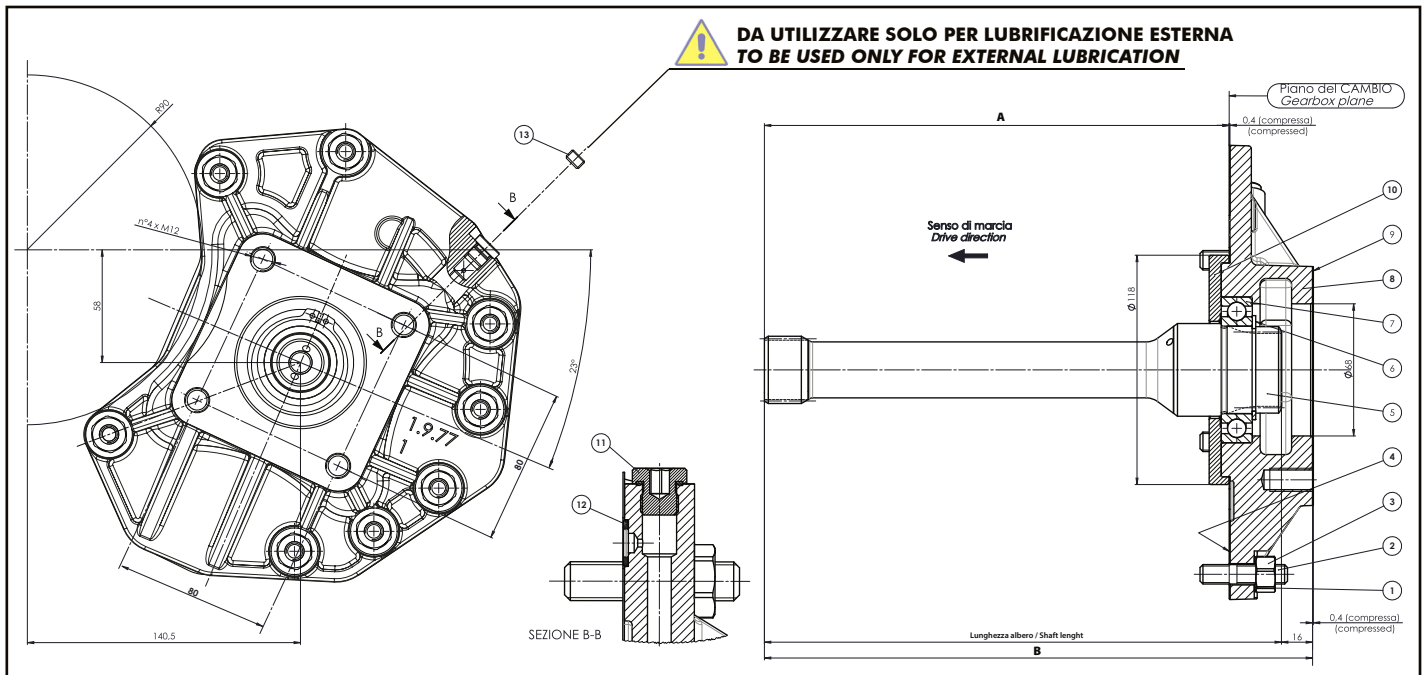

Kit completo Complete kit	Albero corredo Quill shaft	Tipo di cambio Gearbox type	A	B	Lunghezza albero Shaft length
09391610336	52100001291	Detroit DT12 OD-OC-DC Mercedes G291-12, G340-12	239	282	266
09391610425	52100001317	Mercedes G291-12+Voith, G340-12+Voith	267	310	294

N°	Codice / Code	Descrizione / Description	Q.
1	50101800105	Rondella elastica A10 UNI 8840 / Washer A10 UNI 8840	8
2	50300400198	Prigioniero M10x30 UNI 5911 / Stud M10x30 UNI 5911	8
3	50500400050	Dado M10 CH.17 UNI 5587 / Nut M10 CH.17 UNI 5587	8
4	50700101389	Guarnizione piastra PTO-CAMBIO / PTO - gearbox gasket	1
5	52100001291	Albero di corredo / Quill shaft Detroit DT12 OD-OC-DC / Mercedes G291-12, G340-12	1
	52100001317	Albero di corredo / Quill shaft Mercedes G291-12+Voith, G340-12+Voith	
6	50100200425	Anello elastico 45E / Circlip 45E	1
7	51000145755	Cuscinetto a sfere 45x75x16 / Ball bearing 45x75x16	1
8	52800701567	Flangia CAMBIO-PTO / Gearbox - PTO flange	1
9	50700100077	Guarnizione finestra ISO 7707 / Gasket	1
10	53400000179	Anello centraggio / Centering ring	1
11	11500900016	Tappo acciaio TCEI 1/8" / Plug	1
12	50600600108	Guarnizione OR 108 (1.78x8.73) - OR 108 gasket (1.78x8.73)	1
13	50401000018	Grano conico 1/16" NPTF / Tapered grub screw 1/16" NPTF	1

pag.35

OMFB
HYDRAULIC COMPONENTS

O.M.F.B. S.p.A. Hydraulic Components
We reserve the right to make any changes without notice.
Edition 2007.12 No reproduction, however partial, is permitted.
Via Cave, 7/9 25050 Provaglio d'Iseo (Brescia) Italy Tel.: +39.030.9830611
Fax: +39.030.9839207-208 Internet:www.omfb.it e-mail:contatti@omfb.it

**COMPANY WITH
QUALITY SYSTEM
CERTIFIED BY DNV GL
= ISO 9001:2015 =**

11/04/2022

99709391636 Rev: AA

La flangia fornita è predisposta **DI SERIE** per una **LUBRIFICAZIONE INTERNA** delle PTO montate.
The flange is prepared for **INTERNAL LUBRICATION** to the PTO fitted together **AS A STANDARD**.

**LUBRIFICA INTERNA
(CONFIGURAZIONE STANDARD OMFB)
INTERNAL LUBRICATION
(OMFB STANDARD CONFIGURATION)**

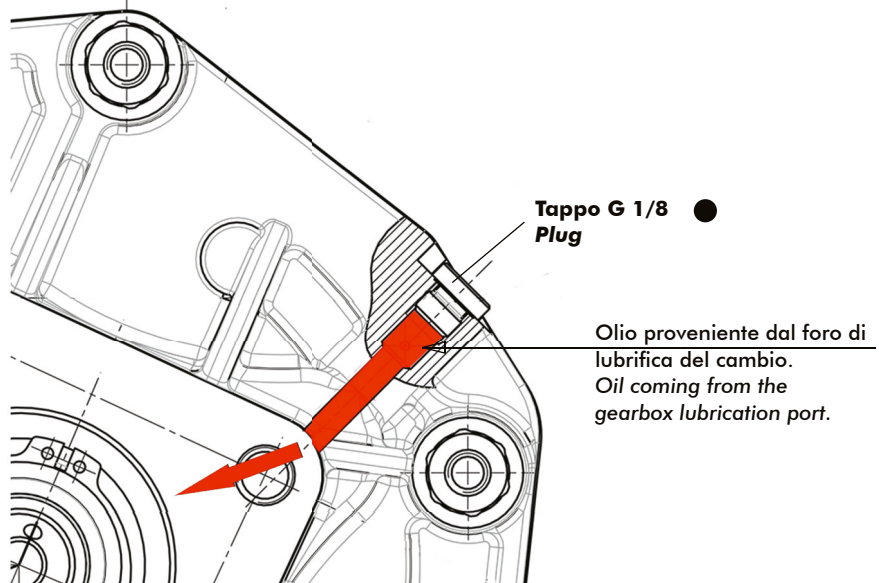

Prima di iniziare il montaggio, è necessario porre attenzione a quanto indicato di seguito:
in caso di montaggio di PTO doppia uscita, singola uscita in posizione orizzontale o singola uscita in posizione verticale con l'uscita verso l'alto, è **NECESSARIO** lubrificare le PTO stesse mediante kit di lubrifica appositamente predisposti. Per questo è **INDISPENSABILE** rimuovere ed eliminare il tappo G 1/8 ● e chiudere, mediante il grano conico fornito ■, il passaggio di olio all'interno delle PTO, in modo da costringerne il flusso nel tubo esterno. L'eventuale kit di lubrifica si individua e si monta come indicato in **Tabella 1**.





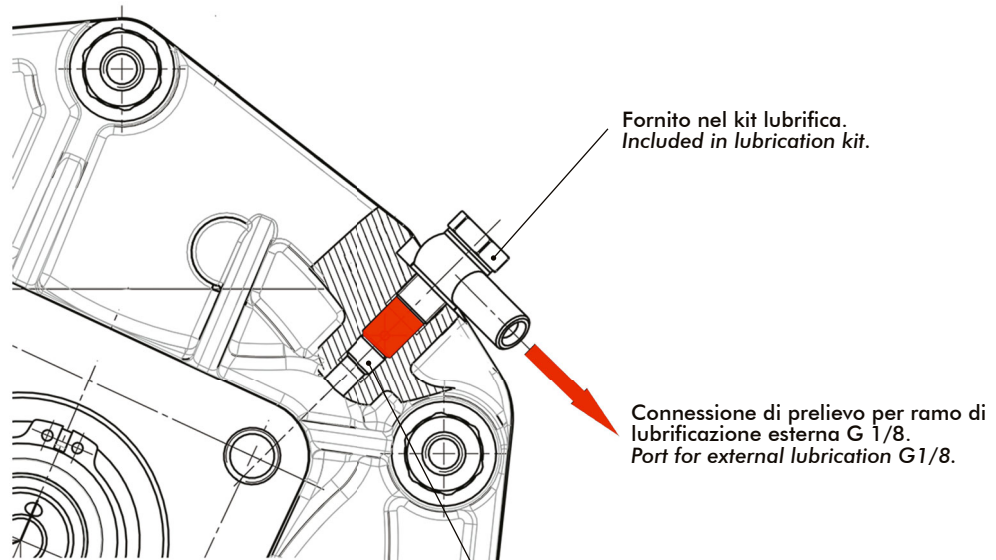







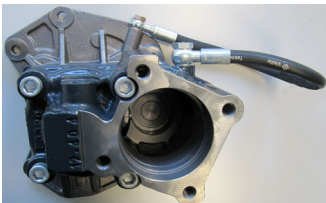

Before starting the mounting operation it is necessary to follow carefully this procedure:
in case of mounting of double output PTO's, single output PTO's in horizontal or vertical UP position it is necessary to lubricate those PTO's by using the specific lubrication kits. To do so it is **STRICTLY** necessary remove and dispose the G1/8 plug ●; close the PTO internal oil flow by using the tapered grub screw ■ supplied in the kit in such a way to force the oil flow to the external pipe. The proper lubrication kit can be identified and fitted as shown in the **Table 1**.

**CONFIGURAZIONE
LUBRIFICA ESTERNA
EXTERNAL LUBRICATION
CONFIGURATION**

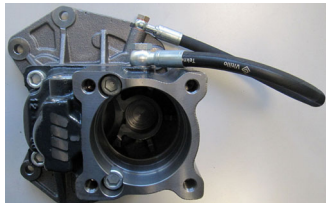

ATTENZIONE: in questo caso è necessario chiudere il ramo di lubrificazione interna con il grano conico fornito 1/16"NPT (50401000018). ■

ATTENTION: in this case it is necessary to close the PTO internal oil flow by using the tapered grub screw 1/16"NPT (50401000018) supplied. ■

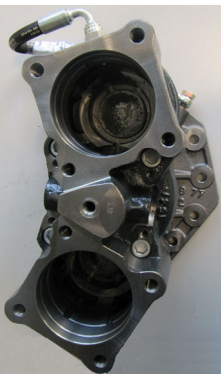
PTO	MONTAGGIO PTO PTO MOUNTING	KIT LUBRIFICA LUBE KIT	IMMAGINE MONTAGGIO MOUNTING PICTURES
POWERFUL	<p>Montaggio verticale uscita in basso</p> <p>Vertical mounting low output</p> 	<p>NON NECESSARIO</p> <p>NOT NECESSARY</p>	
	<p>Montaggio orizzontale uscita laterale</p> <p>Horizontal mounting side output</p> 	 <p>09400100225 OCCHIELLO-OCCHIELLO WITH EYE-WITH EYE</p>	
	<p>Montaggio verticale uscita in alto</p> <p>Vertical mounting up output</p> 	 <p>09400100234 DIRITTO-CON OCCHIELLO STRAIGHT-WITH EYE</p>	
POWERTRUCK	<p>Montaggio verticale uscita in basso</p> <p>Vertical mounting low output</p> 	<p>NON NECESSARIO</p> <p>NOT NECESSARY</p>	
	<p>Montaggio orizzontale uscita laterale</p> <p>Horizontal mounting side output</p> 	 <p>09400100225 OCCHIELLO-OCCHIELLO WITH EYE-WITH EYE</p>	
	<p>Montaggio verticale uscita in alto</p> <p>Vertical mounting up output</p> 	 <p>09400100243 OCCHIELLO-90° WITH EYE-90°</p>	
<p>PTO DOPPIA USCITA Ø68</p> <p>DOUBLE OUTPUT PTO Ø68</p> <p>010034 010036 010037 010039</p>		 <p>09400100243 OCCHIELLO-90° WITH EYE-90°</p>	

99740009310

11/04/2022

99709391636 Rev: AA

Tabella / Table 1