

ALBERO DI CORREDO QUILL SHAFT HEAVY DUTY

CODICE
CODE

09301080053

"ZF AS-TRONIC NO INTARDER"

**ZF AS-TRONIC
12AS 1630-16AS 2430**

02/03/2021

Albero di corredo da utilizzare per il montaggio di pompe pesanti e/o impieghi gravosi. Il fissaggio al cambio con 9 fori consente di distribuire su più punti il momento peso di PTO e pompa. La flangia è costruita per prelevare olio in pressione dal foro appositamente presente sul cambio ed utilizzarlo per la lubrificazione interna o esterna della PTO.

Quill shaft kit to be used for heavy duty pumps and/or applications. The fitment to the gearbox based on 9 holes spreads the mass moment of PTO/pump assembly equally over more points. The flange is designed to take out pressurised oil from the gearbox through the dedicated port available on the transmission and to get use of it either for internal or external PTO lubrication.

99740009310

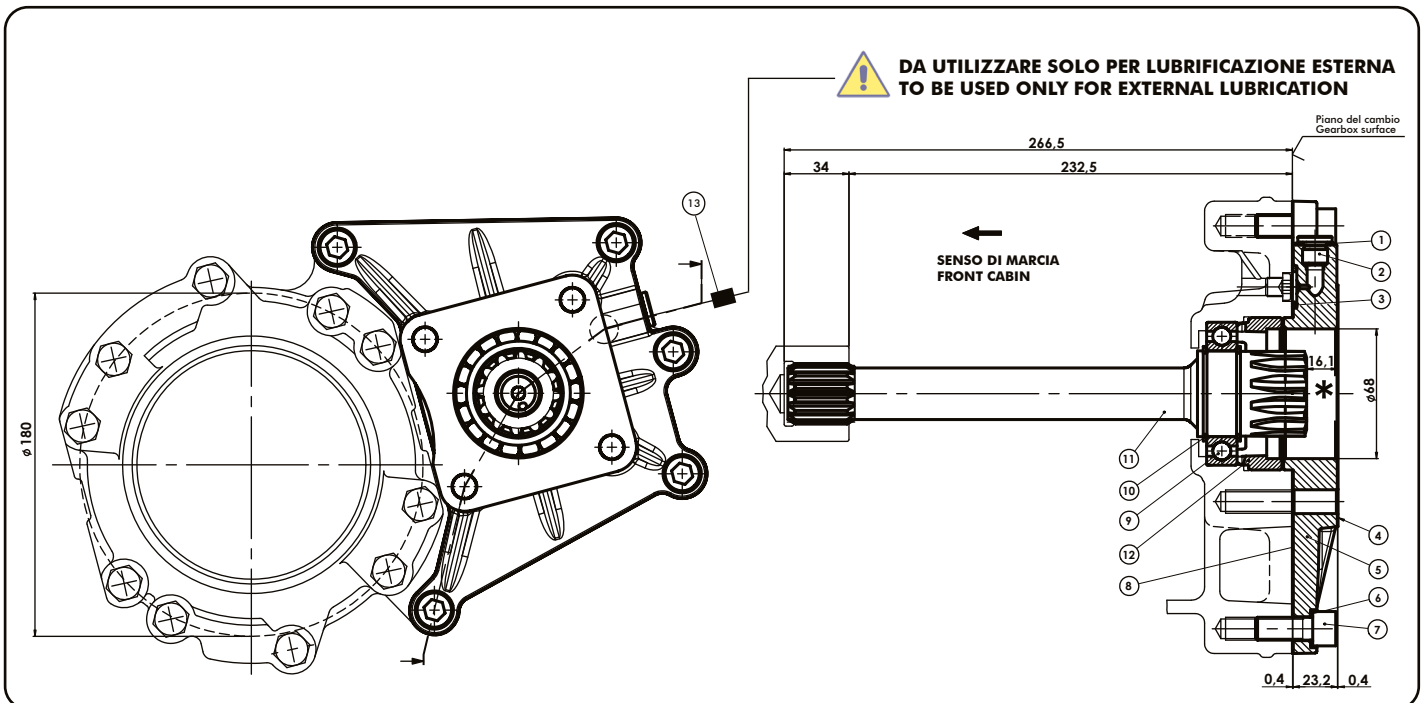
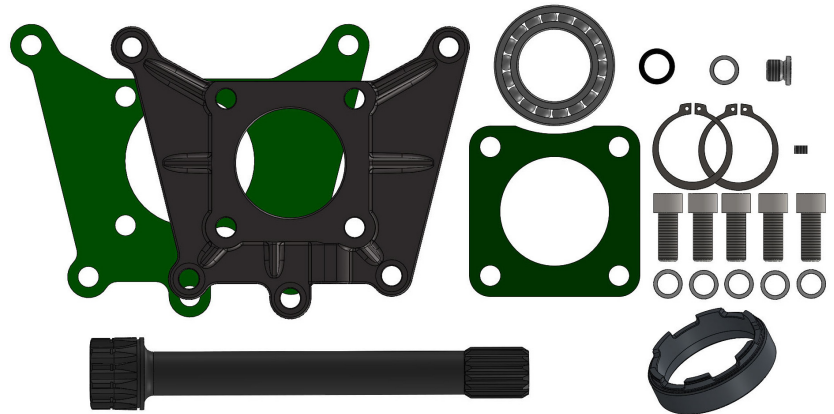

31/03/2014

99709310053 Rev. AA

N°	Codice / Code	Descrizione / Description	Q.
1	11600900158	RONDELLA ALLUMINIO/ALUMINIUM WASHER 13,5X18X1,5 (1/4")	1
2	11500600117	TAPPO CIECO ACCIAIO/ STEEL PLUG TCE 1/4" DIN 908	1
3	50600600172	GUARNIZIONE O-R / OR 122 3068 (2.62 X 17.13) FKM/FPM	1
4	50700100077	GUARNIZIONE / GASKET ISO 7707 ø68	1
5	51500701671	FLANGIA / FLANGE PTO-CAMBIO/GEARBOX	1
6	50102000129	RONDELLA SCHNORR / SCHNORR WASHER x M 12 TIPO/TYPE S	5
7	50200500546	VITE / SCREW TCE UNI 5931 M12 x30	5
8	50700101218	GUARNIZIONE / GASKET PTO-CAMBIO/GEARBOX	1
9	51000145755	CUSCINETTO A SFERE / BALL BEARING 45x75x16 EUR. 6009	1
10	50100200425	ANELLO SEEGER / SEEGER 45 E UNI 7435	2
11	52100001228	ALBERO CORREDO / QUILL SHAFT Z14 L 272mm	1
12	53400300390	ANELLO DISTANZIALE / SPACER RING	1
13	50401000018	GRANO CONICO 1/16" NPTF / TAPERED GRUB SCREW	1

pag.123

OMFB
HYDRAULIC COMPONENTS

O.M.F.B. S.p.A. Hydraulic Components
We reserve the right to make any changes without notice.
Edition 2007.12 No reproduction, however partial, is permitted.
Via Cave, 7/9 25050 Provaglio d'Iseo (Brescia) Italy Tel.: +39.030.9830611
Fax: +39.030.9839207-208 Internet:www.omfb.it e-mail:contatti@omfb.it

COMPANY WITH
QUALITY SYSTEM
CERTIFIED BY DNV GL
= ISO 9001:2015 =

La flangia fornita è predisposta **DI SERIE** per una **LUBRIFICAZIONE INTERNA** delle PTO montate.
The flange is prepared for **INTERNAL LUBRICATION** to the PTO fitted together **AS A STANDARD**.

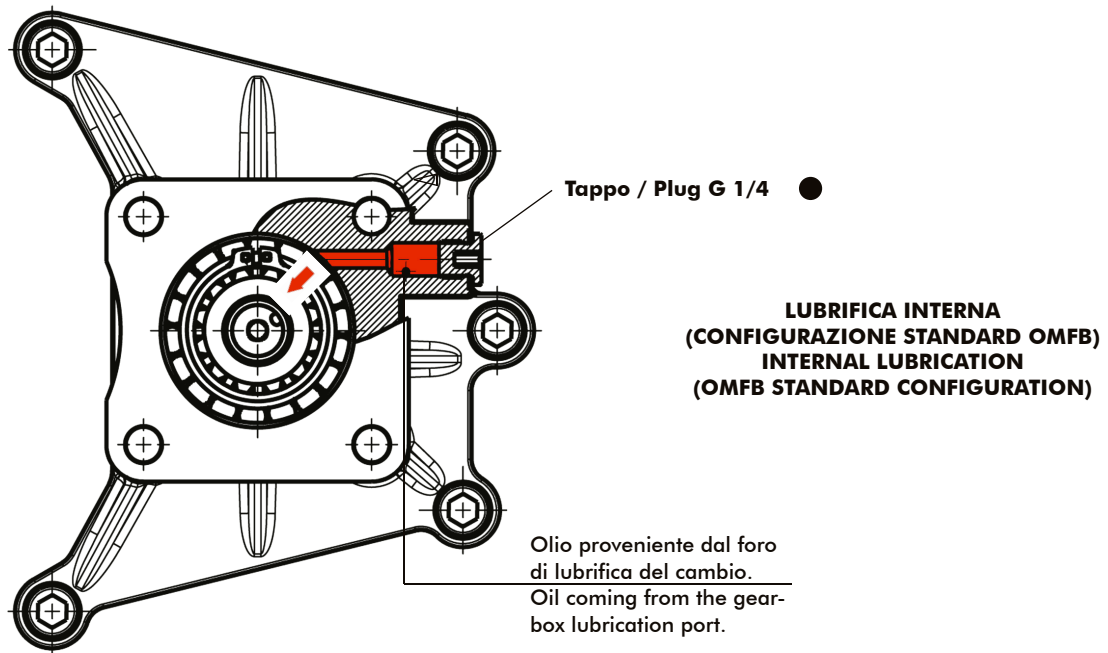

Prima di iniziare il montaggio, è necessario porre attenzione a quanto indicato di seguito:
in caso di montaggio di PTO doppia uscita, singola uscita in posizione orizzontale o singola uscita in posizione verticale con l'uscita verso l'alto, è **NECESSARIO** lubrificare le PTO stesse mediante kit di lubrifica appositamente predisposti. Per questo è **INDISPENSABILE** rimuovere ed eliminare il tappo G 1/4 ● e chiudere, mediante il grano conico fornito ■, il passaggio di olio all'interno delle PTO, in modo da costringerne il flusso nel tubo esterno. L'eventuale kit di lubrifica si individua e si monta come indicato in **Tabella 1**.

Before starting the mounting operation it is necessary to follow carefully this procedure:
in case of mounting of double output PTO's, single output PTO's in horizontal or vertical UP position it is necessary to lubricate those PTO's by using the specific lubrication kits. To do so it is **STRICTLY** necessary remove and dispose the G1/4 plug ●; close the PTO internal oil flow by using the tapered grub screw ■ supplied in the kit in such a way to force the oil flow to the external pipe. The proper lubrication kit can be identified and fitted as shown in the **Table 1**.

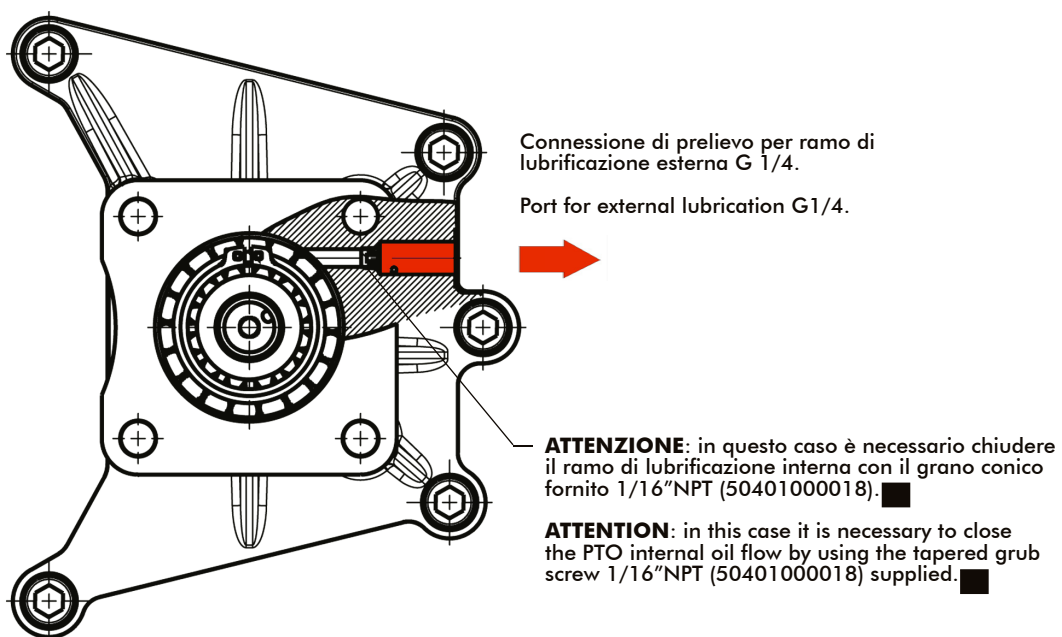

**CONFIGURAZIONE LUBRIFICA ESTERNA
EXTERNAL LUBRICATION CONFIGURATION**













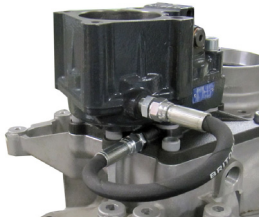



PTO	MONTAGGIO PTO PTO MOUNTING	KIT LUBIFICA LUBRICATION KIT	IMMAGINE MONTAGGIO MOUNTING PICTURES
POWERFUL	Montaggio verticale uscita in basso Vertical mounting low output 	NON NECESSARIO NOT NECESSARY	
	Montaggio orizzontale uscita laterale Horizontal mounting side output 	 09400100181 DIRITTO-DIRITTO STRAIGHT-STRAIGHT	
	Montaggio verticale uscita in alto Vertical mounting up output 	 09400100190 CON OCCHIELLO-CON OCCHIELLO WITH EYE-WITH EYE	
010071 010072 010073	Montaggio verticale uscita in basso Vertical mounting low output 	NON NECESSARIO NOT NECESSARY	
	Montaggio orizzontale uscita laterale Horizontal mounting side output 	 09400100181 DIRITTO-DIRITTO STRAIGHT-STRAIGHT	
	Montaggio verticale uscita in alto Vertical mounting up output 	 09400100118 DIRITTO-CON OCCHIELLO STRAIGHT-WITH EYE	
PTO DOPPIA USCITA Ø68 DOUBLE OUTPUT PTO Ø68 01003612173 01003912170		 09400100118 DIRITTO-CON OCCHIELLO STRAIGHT-WITH EYE	

Tabella / Table 1

PREPARAZIONE E MONTAGGIO PTO / PTO MOUNTING & PREPARATION

1) Smontare il coperchio posteriore originale e rimuovere eventuali tracce di pasta/prodotto sigillante e di vernice dalla zona indicata.

Togliere il tappo M10 nel cambio.

*Take out the original rear cover and remove any presence of sealant or painting. **Remove the M10 plug from the gearbox.***

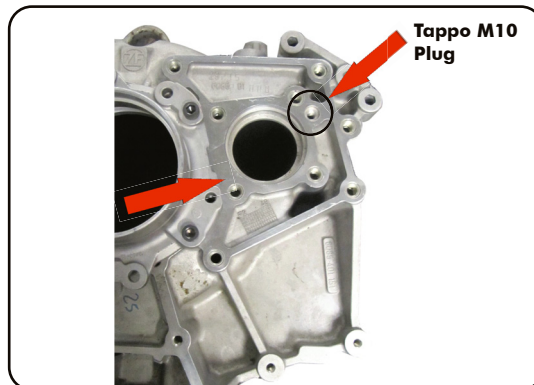

2) Montare l'albero di corredo completo nel cambio.
Fit in the gearbox the complete quill shaft.

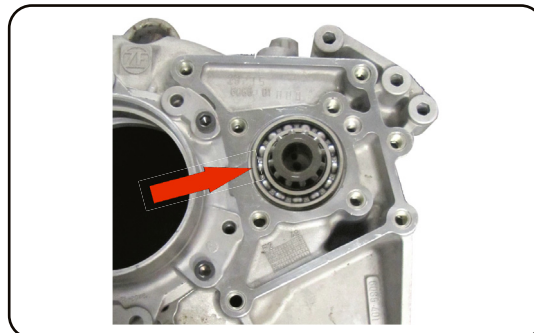

3) Posizionare la guarnizione.
Mount the gasket.

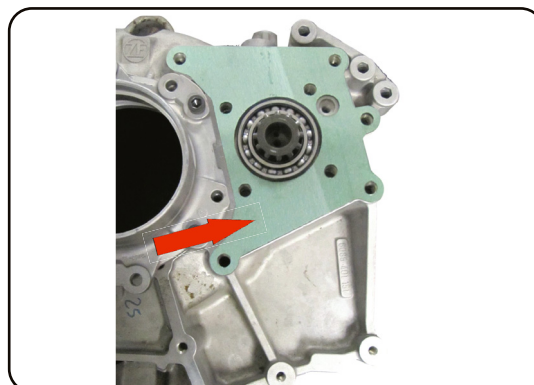

4) Montare nella flangia la guarnizione OR.
Fit the OR gasket in the flange.



In questa fase, **SE NECESSARIA LUBRIFICA ESTERNA**, rimuovere il tappo G 1/4 e montare il grano filettato 1/16" NPT.

IF EXTERNAL LUBRICATION IS REQUIRED, please remove the G1/4 plug and fit the tapered grub screw 1/16"NPT.

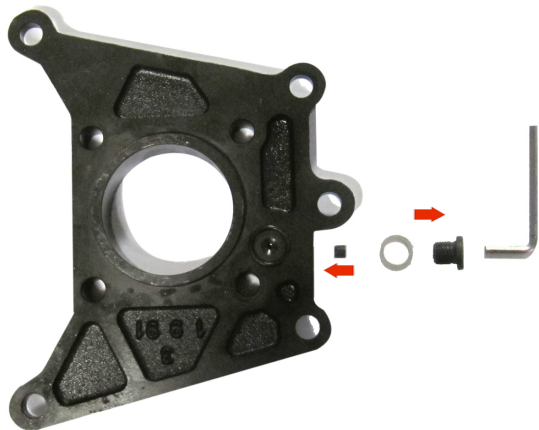

02/03/2021

99740009310

31/03/2014

99709310053 Rev: AA

- 5) Montare la flangia rispettando le coppie di serraggio.
Fit the flange watching the tightening torque.

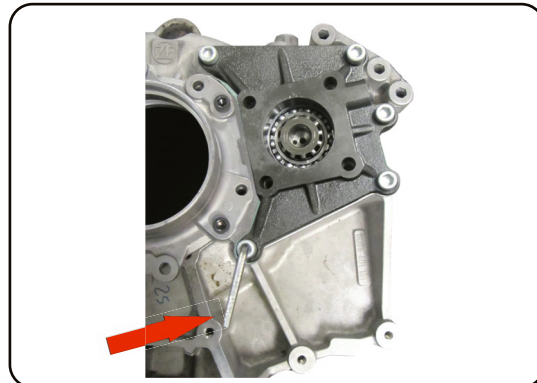

- 6) Controllare la quota indicata con * nell'ingombro. Se diversa, il nostro Servizio Tecnico Commerciale è a completa disposizione per qualsiasi ulteriore chiarimento.

*Make sure about the given value * of the drawing. If different please contact our Technical Sales Office.*

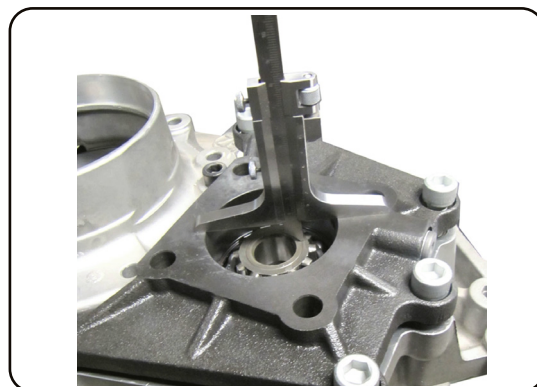

- 7) Se necessario montare il tubo di lubrifica (vedere Tabella 1).
If necessary fit the lubrication hose (see table 1).

- 8) Montare la guarnizione indicata in figura.
Fit the gasket as shown in picture.

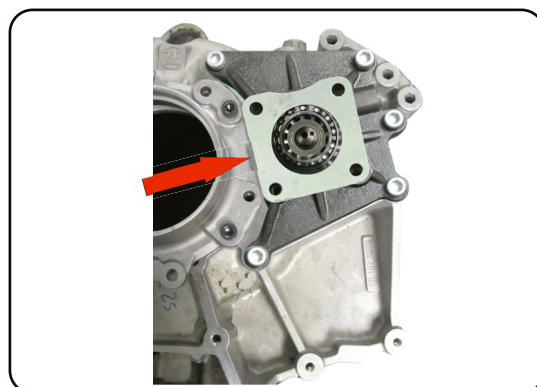

- 9) Montare la PTO.
Mount the PTO.

Per ulteriori informazioni sul montaggio della PTO, consultare l'istruzione allegata alla PTO.
In order to get more information concerning PTO installation please check the Instructions sheet delivered with the PTO.

COPPIA DI SERRAGGIO						
Diametro filetto - Vite (mm)	M8	M10	M12	UNC 3/8	UNC 7/16	
Coppia chius. viti e dadi (Nm)	25	50	80	25	60	
Coppia di chius. prigionieri (Nm)	10	20	30	10	20	



Per i cambi in alluminio la coppia di serraggio deve essere diminuita del 30%.
Nota per la coppia di serraggio: le coppie di serraggio indicate sono puramente indicative e non sostituiscono le indicazioni date dal costruttore del veicolo o dal costruttore del cambio.

TIGHTENING TORQUE						
Thread diameter - Screw (mm)	M8	M10	M12	UNC 3/8	UNC 7/16	
Screws and nuts torque (Nm)	25	50	80	25	60	
Studs torque (Nm)	10	20	30	10	20	



For aluminium gearboxes the tightening torque needs to be reduced by 30%.
Note on the tightening torque: the tightening torques reported are only meant as a guide and do not replace the indications given by the vehicle's manufacturer or the gearbox manufacturer.

02/03/2021

99740009310

31/03/2014

99709310053 Rev.: AA