

# ALBERO DI CORREDO QUILL SHAFT

"ZF ECOSPLIT + INTARDER  
SU VEICOLI 4 ASSI"  
"ZF ECOSPLIT + INTARDER  
ON 4 AXLES VEHICLES"

**09301044028**  
**09301044046**

**ZF**



Kit albero adatto solo per PTO tipo  
**HIGH-POWER** cod. 010044.....

In fase di montaggio della PTO sul cambio si  
raccomanda di rispettare le istruzioni allegate  
cod. istruzione 99700101757.

Quill shaft suitable only for PTO **HIGH-POWER**  
p/n 010044.....  
Please follow attached instructions p/n  
99700101757.

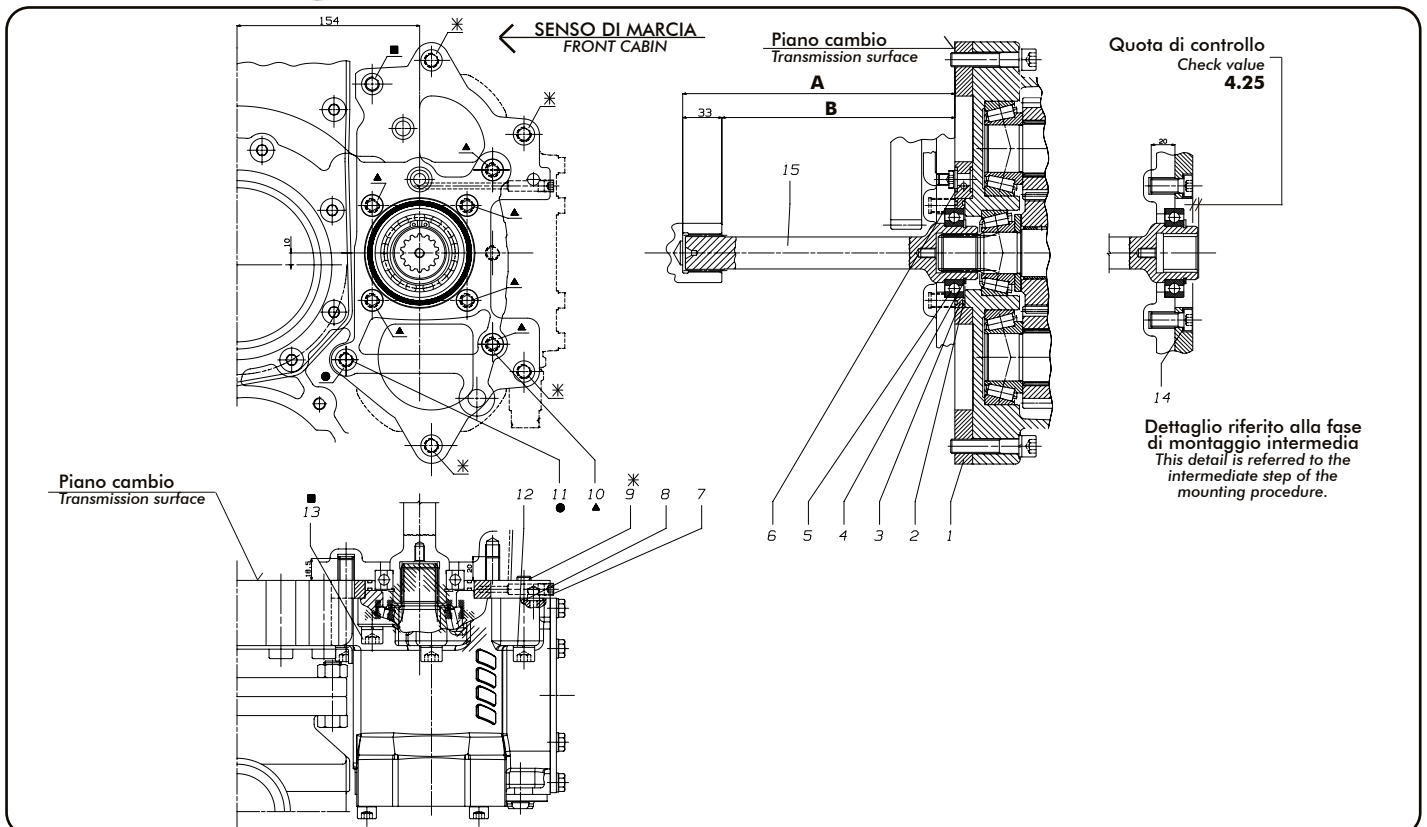

N°	Codice / Code	Descrizione / Description	Q.
1	51500701537	Flangia intermedia fissaggio PTO / Intermediate flange PTO anchorage	1
2	50600608026	Guarnizione Øi 80.6 corda 2.62 FKM/FPM / Gasket	2
3	53400200524	Anello di centraggio / Centering ring	1
4	50100200425	Anello seeger / Seeger ring E 45	1
5	51000145755	Cuscinetto a sfere / Ball bearing 45x75x16 EUR. 6009	1
6	50600603062	O-ring 3062 FKM/FPM	2
7	50401000063	Grano conico G 1/8" / Plug	1
8	50600600332	O-ring 3043 FKM/FPM	1
9 *	50200500608	Vite TCE / TCE Screws M12x60 UNI 5931	4
10 ▲	50200000792	Vite TCE / TCE Screws M12x28 DIN 7984	6
11 ●	50200500635	Vite TCE / TCE Screws M12x75 UNI 5931	1
12	50100800063	Rondella elastica x M12 / Washer for M12 DIN 7980	6
13 ■	50200500573	Vite TCE / TCE Screws M12x45 UNI 5931	1
14	50102000129	Rondella elastica x M12 SCHNORR / Washer	6
15	Vedi tabella See table	Albero di corredo / Quill shaft	1

Codice / Code	Cambio / Gearbox	Albero / Quill shaft	A	B
09301044028	ZF ECOSPLIT 16S-151 4 ASSI + IT	52100001068	229.5	196.5
09301044046	ZF ECOSPLIT 16S-251 4 ASSI + IT	52100001362	265.05	232.05

pag.97