

# ALBERO DI CORREDO QUILL SHAFT "EATON TWINSPLITTER + RETARDER VOITH R115 TS-TSO 11612.....13612"

CODICE  
CODE

**09300400037**

**EATON**



02/03/2021

99740009310

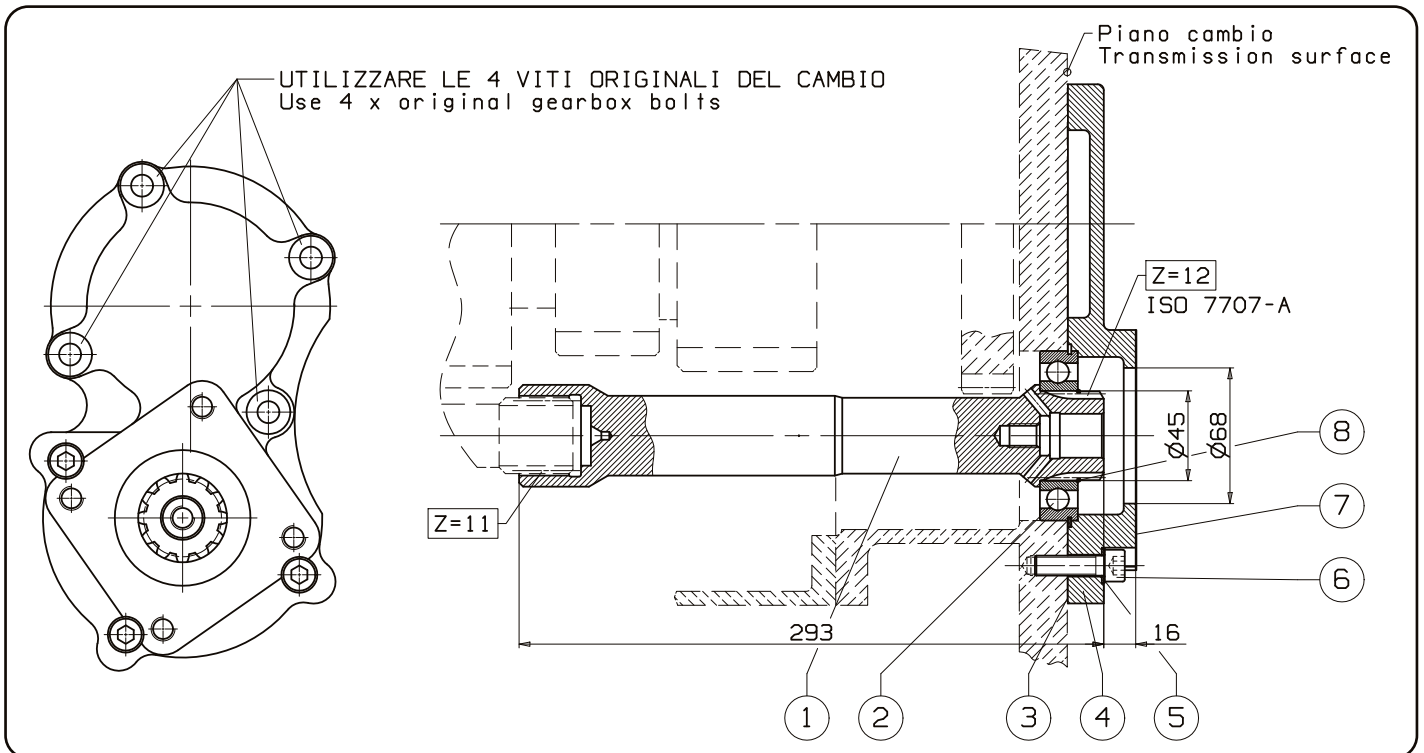

12/11/2013

99709304037 Rev: AA

N°	Codice Code	Descrizione Description	Q.
1	52100000809	Albero di corredo / Quill shaft	1
2	51000300489	Cuscinetto a sfere / Ball bearing 45x85x19	1
3	50700100424	Guarnizione twinsplitter posteriore / Rear twinsplitter gasket	1
4	52800700086	Flangia accoppiamento cambio-pto / Shift-PTO coupling flange	1
5	50101800105	Rosetta elastica convessa / Washer	3
6	50200400565	Vite TCE / TCE Screws M10x35 UNI 6931	3
7	50700100077	Guarnizione / Gasket	1
8	51200000068	Anello ferma cuscinetto / Bearing back-up ring	1

pag.9

**OMFB**  
HYDRAULIC COMPONENTS

O.M.F.B. S.p.A. Hydraulic Components  
We reserve the right to make any changes without notice.  
Edition 2007.12 No reproduction, however partial, is permitted.  
Via Cave, 7/9 25050 Provaglio d'Iseo (Brescia) Italy Tel.: +39.030.9830611  
Fax: +39.030.9839207-208 Internet:www.omfb.it e-mail:contatti@omfb.it

COMPANY WITH  
QUALITY SYSTEM  
CERTIFIED BY DNV GL  
= ISO 9001:2015 =

1) Smontare il coperchio posteriore originale e rimuovere eventuali tracce di pasta/prodotto sigillante e di vernice dalla zona indicata. Inserire l'albero di corredo nel cambio e montare la flangia di accoppiamento.

1) Take out the original rear cover and remove any presence of sealant or painting. Fit in the gearbox the complete quill shaft and flange.

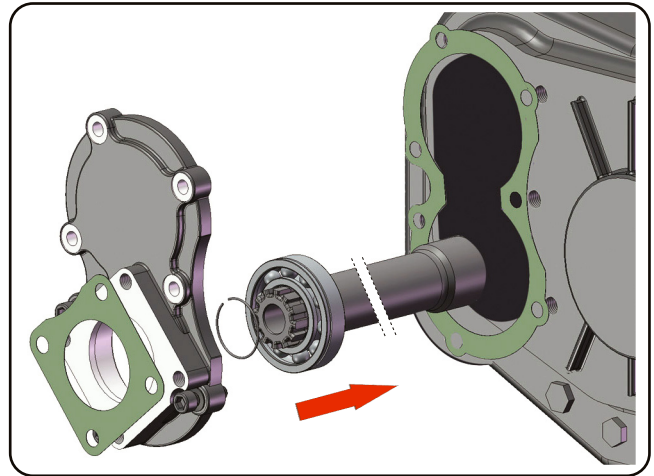

02/03/2021

99740009310

**COPPIA DI SERRAGGIO**

Diametro filetto - Vite (mm)	M8	M10	M12	UNC 3/8	UNC 7/16
Coppia chius. viti e dadi (Nm)	25	50	80	25	60
Coppia di chius. prigionieri (Nm)	10	20	30	10	20



Per i cambi in alluminio la coppia di serraggio deve essere diminuita del 30%.

Nota per la coppia di serraggio: le coppie di serraggio indicate sono puramente indicative e non sostituiscono le indicazioni date dal costruttore del veicolo o dal costruttore del cambio.

**TIGHTENING TORQUE**

Thread diameter - Screw (mm)	M8	M10	M12	UNC 3/8	UNC 7/16
Screws and nuts torque (Nm)	25	50	80	25	60
Studs torque (Nm)	10	20	30	10	20



For aluminium gearboxes the tightening torque needs to be reduced by 30%.

Note on the tightening torque: the tightening torques reported are only means as a guide and do not replace the indications given by the vehicle's manufacturer or the gearbox manufacturer.

Per ulteriori informazioni sul montaggio della PTO, consultare l'istruzione allegata alla PTO.

In order to get more information concerning PTO installation please check the Instructions delivered with the PTO.

12/11/2013

99709304037 Rev: AA