

ALBERO DI CORREDO QUILL SHAFT "ZF 16S 112 ECOSPLIT 1° SERIE"

CODICE
CODE

09300200020

ZF

02/03/2021

99740009310

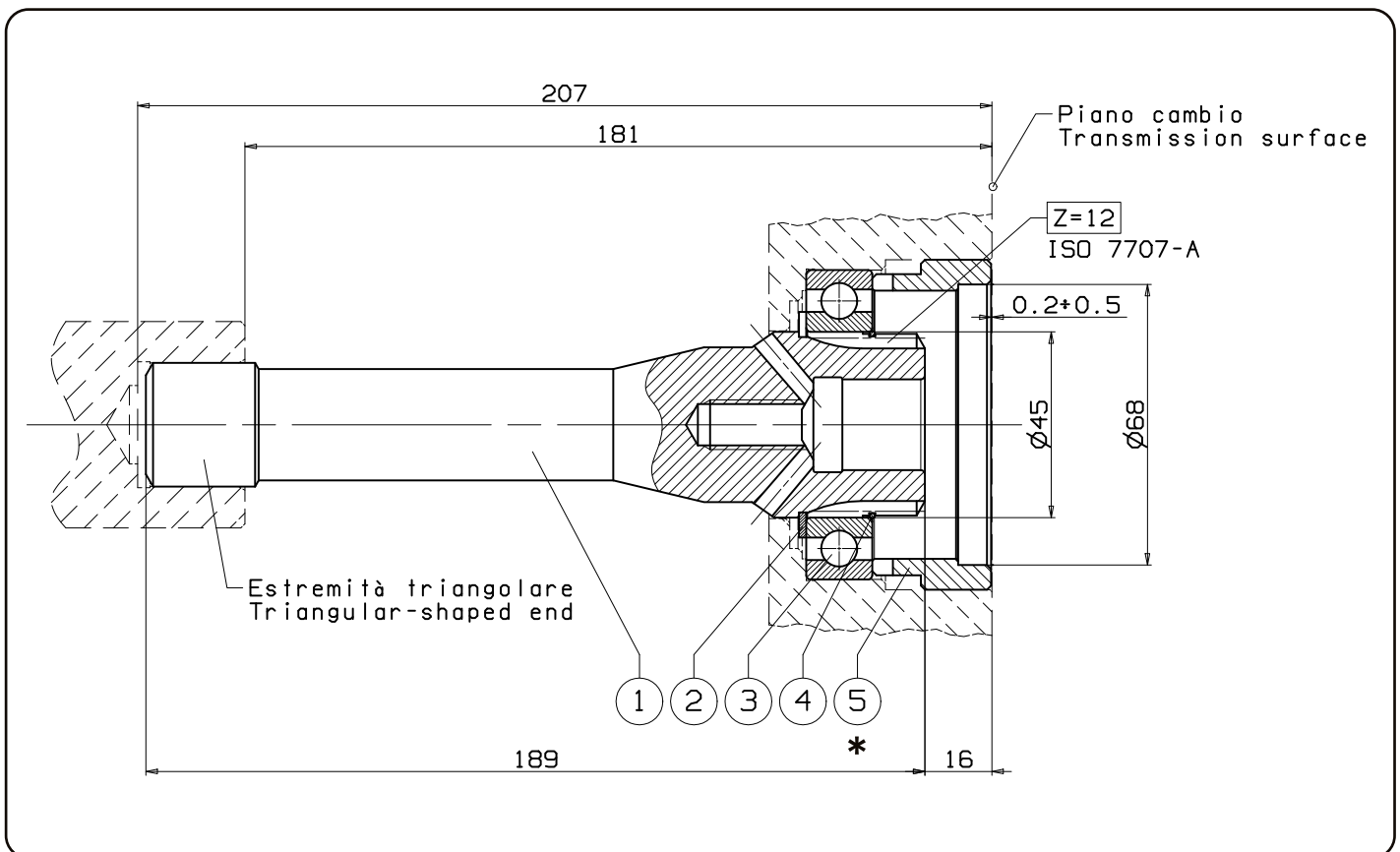
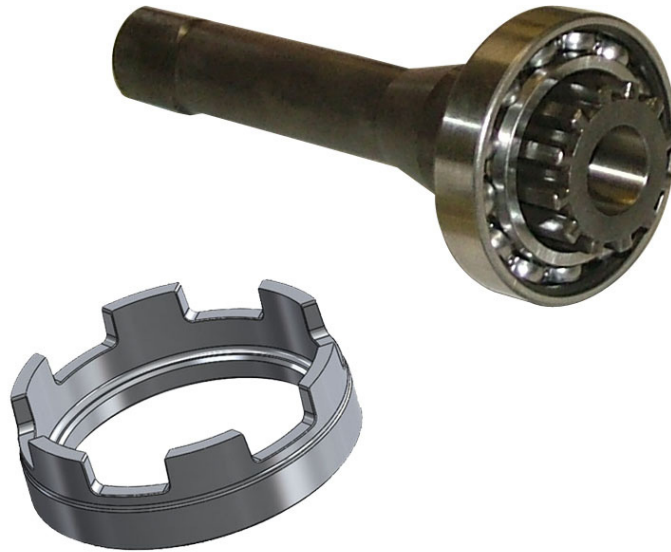

12/11/2013

99709302020 Rev: AA

N°	Codice Code	Descrizione Description	Q.
1	5210000149	Albero di corredo / Quill shaft	1
2	50100200425	Anello seeger / Circlip E 45	1
3	51000145755	Cuscinetto a sfere / Ball bearing 45x75x16	1
4	51200000068	Anello ferma cuscinetto / Bearing back-up ring	1
5	53400200079	Anello centraggio - guida PTO / Centering ring - PTO guide	1

pag.59

OMFB
HYDRAULIC COMPONENTS

O.M.F.B. S.p.A. Hydraulic Components
We reserve the right to make any changes without notice.
Edition 2007.12 No reproduction, however partial, is permitted.
Via Cave, 7/9 25050 Provaglio d'Iseo (Brescia) Italy Tel.: +39.030.9830611
Fax: +39.030.9839207-208 Internet:www.omfb.it e-mail:contatti@omfb.it

COMPANY WITH
QUALITY SYSTEM
CERTIFIED BY DNV GL
= ISO 9001:2015 =

1) Smontare il coperchio posteriore originale e rimuovere eventuali tracce di pasta/prodotto sigillante e di vernice dalla zona indicata.

Take out the original rear cover and remove any presence of sealant or painting.

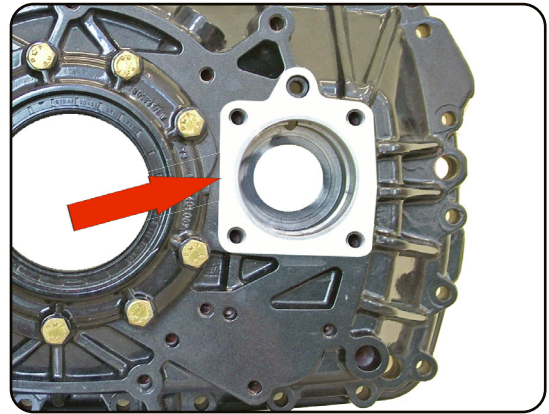

2) Inserire l'albero di corredo nel cambio, verificando che l'anello * sia interno di 0,2-0,5 mm rispetto al Piano del cambio. Montare la PTO interponendo la guarnizione a corredo.

*Fit in the gearbox the complete quill shaft. Check that Ring * is situated 0.2-0.5mm inside respect to gearbox surface. Fit the PTO placing the supplied gasket.*

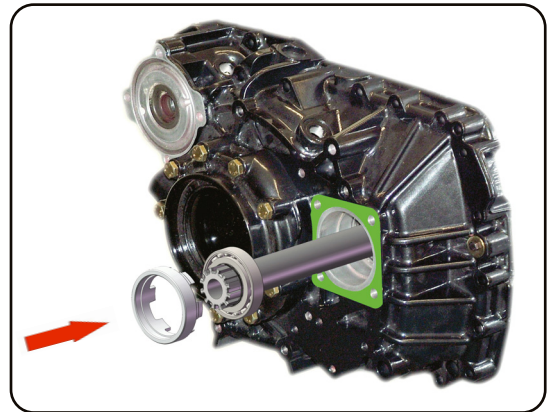

COPPIA DI SERRAGGIO

Diametro filetto - Vite (mm)	M8	M10	M12	UNC 3/8	UNC 7/16
Coppia chius. viti e dadi (Nm)	25	50	80	25	60
Coppia di chius. prigionieri (Nm)	10	20	30	10	20



Per i cambi in alluminio la coppia di serraggio deve essere diminuita del 30%.

Nota per la coppia di serraggio: le coppie di serraggio indicate sono puramente indicative e non sostituiscono le indicazioni date dal costruttore del veicolo o dal costruttore del cambio.

TIGHTENING TORQUE

Thread diameter - Screw (mm)	M8	M10	M12	UNC 3/8	UNC 7/16
Screws and nuts torque (Nm)	25	50	80	25	60
Studs torque (Nm)	10	20	30	10	20



For aluminium gearboxes the tightening torque needs to be reduced by 30%.

Note on the tightening torque: the tightening torques reported are only means as a guide and do not replace the indications given by the vehicle's manufacturer or the gearbox manufacturer.

Per ulteriori informazioni sul montaggio della PTO, consultare l'istruzione allegata alla PTO.
In order to get more information concerning PTO installation please check the Instructions delivered with the PTO.