

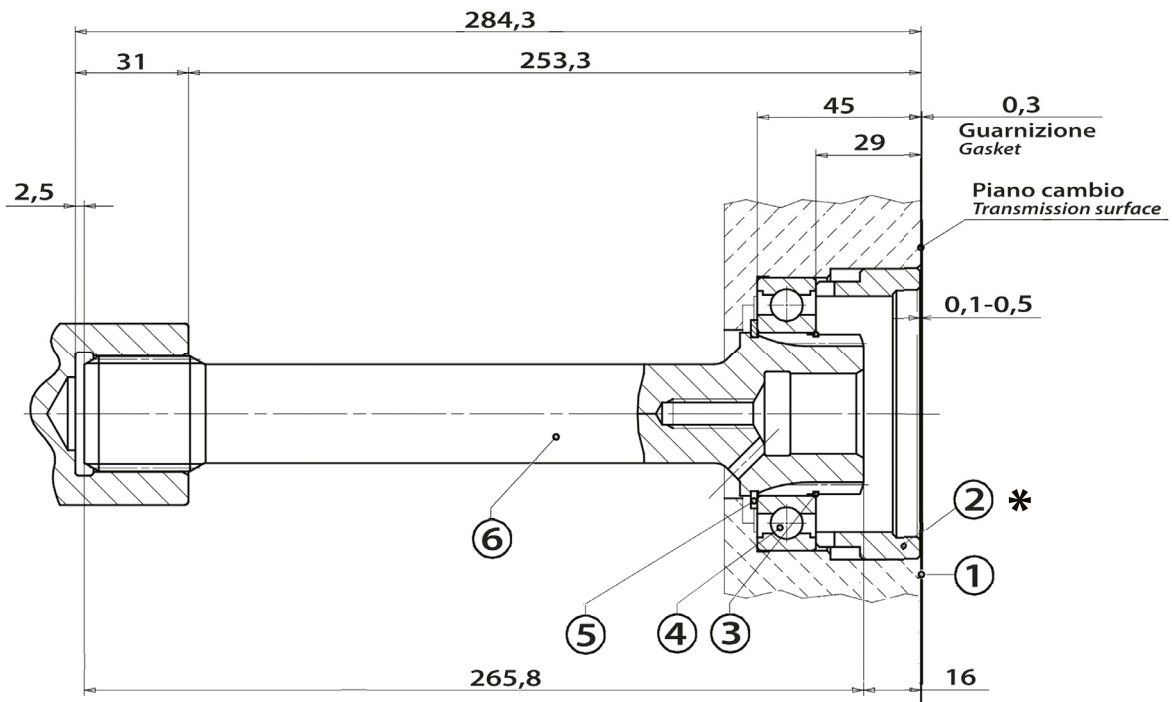

**Ingombro / Dimensions**



N°	Codice Code	Descrizione Description	Q.
1	50700100077	Guarnizione / Gasket	1
2	53400200079	Anello centraggio - guida PTO / PTO guiding ring	1
3	51200000068	Anello ferma cuscinetto / Bearing back-up ring	1
4	51000145755	Cuscinetto a sfere 45x75x16 / Ball bearing 45x75x16	1
5	50100200425	Anello seeger E 45 / Circlip E 45	1
6	52100001072	Albero di corredo / Quill shaft	1

- 1) Smontare il coperchio posteriore originale.  
*Take out the original rear cover*

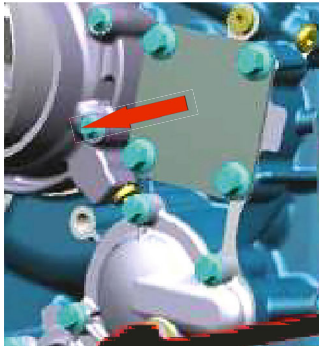

- 2) Rimuovere eventuali tracce di pasta/prodotto sigillante e di vernice dalla zona indicata.  
*Remove any presence of sealant or painting.*



- 3) Inserire l'albero di corredo nel cambio, verificando che l'anello \* sia interno di 0,1-0,5 mm rispetto al Piano del cambio. Montare la PTO interponendo la guarnizione a corredo.

*Fit in the gearbox the complete quill shaft. Check that Ring \* is situated 0.1-0.5mm inside respect to gearbox surface. Fit the PTO placing the supplied gasket.*

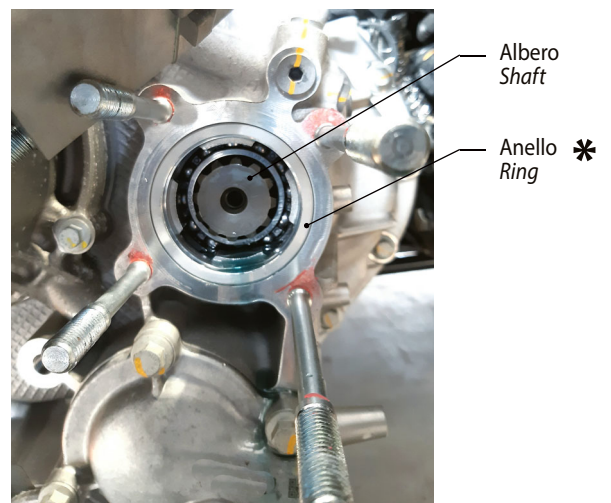

- 4) Montare la PTO interponendo la guarnizione a corredo.  
*Fit the PTO placing the supplied gasket.*

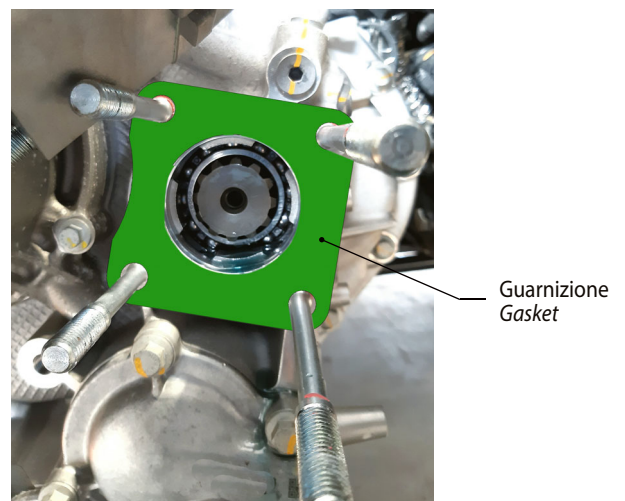

**COPPIA DI SERRAGGIO**

Diametro filetto - Vite (mm)	M8	M10	M12	UNC 3/8	UNC 7/16
Coppia chius. viti e dadi (Nm)	25	50	80	25	60
Coppia di chius. prigionieri (Nm)	10	20	30	10	20



Per i cambi in alluminio la coppia di serraggio deve essere diminuita del 30%.  
Nota per la coppia di serraggio: le coppie di serraggio indicate sono puramente indicative e non sostituiscono le indicazioni date dal costruttore del veicolo o dal costruttore del cambio.

**TIGHTENING TORQUE**

Thread diameter - Screw (mm)	M8	M10	M12	UNC 3/8	UNC 7/16
Screws and nuts torque (Nm)	25	50	80	25	60
Studs torque (Nm)	10	20	30	10	20



For aluminium gearboxes the tightening torque needs to be reduced by 30%.  
Note on the tightening torque: the tightening torques reported are only means as a guide and do not replace the indications given by the vehicle's manufacturer of the gearbox manufacturer.

Per ulteriori informazioni sul montaggio della PTO, consultare l'istruzione allegata alla PTO.  
*In order to get more information concerning PTO installation please check the Instructions delivered with the PTO.*