

**ISTRUZIONI MONTAGGIO KIT
SCARICO AUSILIARIO G 1 PER
SERBATOI INT. 115mm
EXTRA RETURN KIT 1" FOR OIL
TANKS WITH 115 mm MOUNTING
PLATE MOUNTING INSTRUCTIONS**

**CODICE KIT
KIT CODE**

13590400056

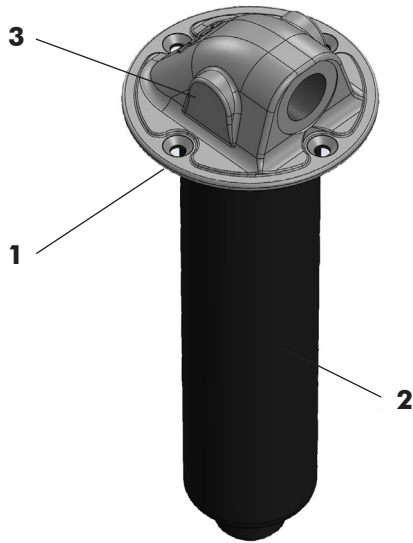

**Kit montato
Mounted kit**

Pos.	Codice / Code	Descrizione / Description	Q.
1	50600002916	Guarnizione 4 fori 4 holes gasket	1
2	50900001859	Contenitore H=323mm filtro immerso Submerged filter plastic recipient H=323mm	1
3	54600200074	Calotta serbatoio Oil tank cap	1

**ISTRUZIONI DI MONTAGGIO
MOUNTING INSTRUCTIONS**

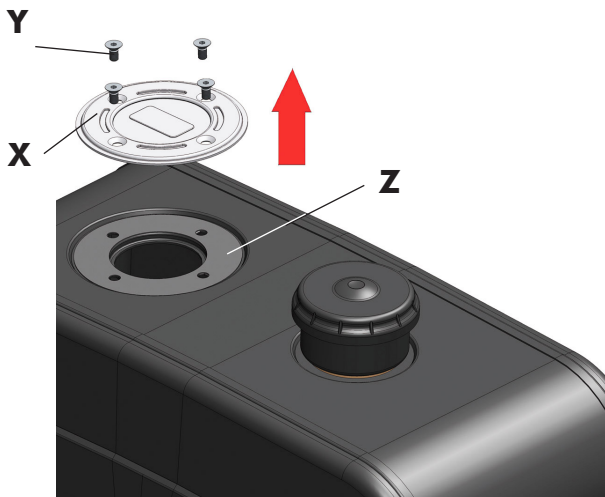

A) Togliere il coperchio X del serbatoio conservando le viti originali Y ed eliminare la guarnizione Z.

Remove the cover X from the oil tank keeping the genuine screws Y whilst dispose of gasket Z.

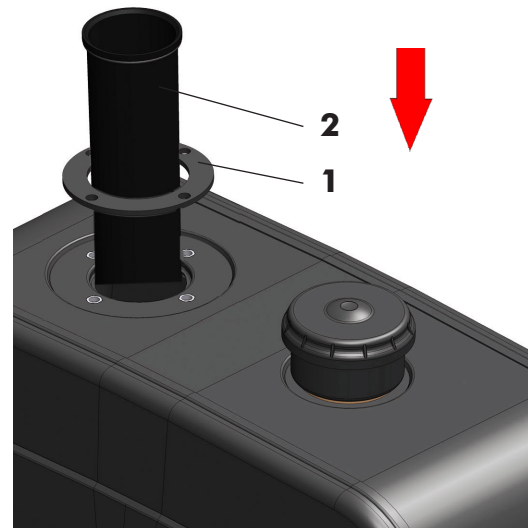

B) Posizionare la nuova guarnizione 1 e inserire il contenitore di plastica pos. 2.

Place the new gasket 1 and insert the plastic recipient pos. 2.

Data: Martedì 28 luglio 2020

Codice foglio: 99700113565 Rev: AB

pag.1



C) Avvitare (nella posizione desiderata) la calotta pos. **3** sul serbatoio, riutilizzando le 4 viti **Y**.
*Using 4 original screws **Y**, tighten the cap pos. **3** (in the suitable position) onto the oil tank.*

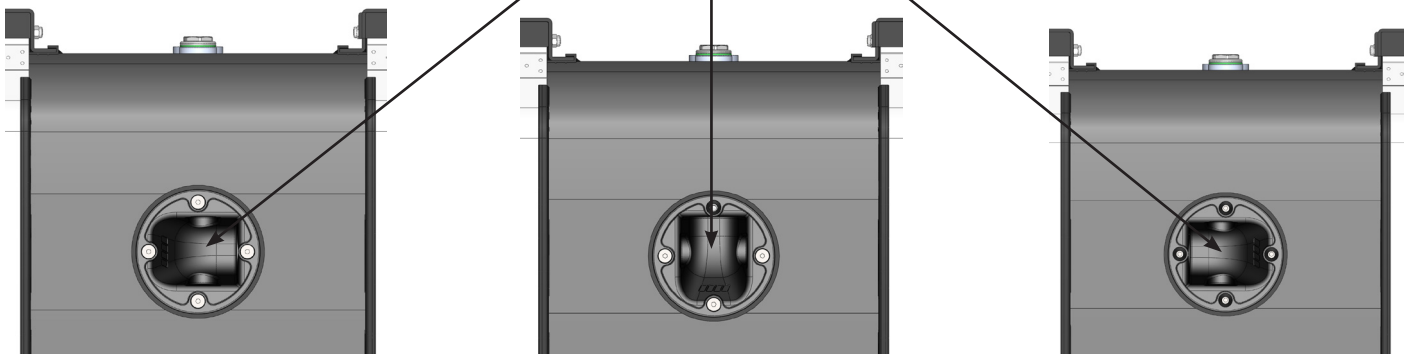

D) Fissare l'adesivo nella posizione indicata.
Attach the sticker on indicated position.