

General	4...
General description	5...
PDI open centre inlet section function	9...
PDI closed centre inlet section function	13...
PDI inlet sections code numbers	18...
PIU solenoid LS unloading valves	23...
PDW working sections code numbers	25...
PDE end sections code numbers	29...
PDS flow control spool	33...
PDR spool centered set	35...
PDS pressure control spool	40...
Modules and code numbers	42...
Shock and suction valves	47...
PDL Electrical LS _{A/B} unloading	49...
PDLD Proportional Electrical LS _{A/B} unloading	53...
PEAC111 Proportional closed loop spool control input signal 0,5 Udc	54...
PEAC112 Proportional closed loop spool control input signal control 0 ÷ 10 V	62...
PEAC116 Proportional closed loop spool control input signal control 4 ÷ 20 mA	70...
PEAC011 Proportional open loop spool control input signal 0,5 Udc	78...
PEAC012 Proportional open loop spool control input signal 0 ÷ 10 V	85...
PEAC016 Proportional open loop spool control input signal 4 ÷ 20 mA	92...
PEAD1 Proportional open loop spool control input signal PWM and ON-OFF	99...
PEAP1 Proportional open loop spool control input signal PWM and ON-OFF	105...
Overall dimension drawing	112...
Product selection chart	132...
Composition form	138...
PDV114 Series	141...
PDV315 Series	297...
CAN - Bus components	
Electronic joysticks	
PDV ATEX version	
Hydraulic remote controls	

General

The **PDV** technology platform, is the latest step in proportional directional valves configuration.

It takes mobile machine control to next level of performance, reliability, and feature stringent technical demands, exacting quality standard, and safety regulations.

Based on load sensing technology, are new breakthrough products with up-graded hydraulic functions that fulfil the ever increasing market demands for improved machines productivity, safety requirements, energy efficient and environmental operations.

They provides also a wide choice of control options, and are meant to be used in hazardous area also, according to **Atex 2014/34/UE Directive and IECEx** protocol.

Safety Conformity assessment

FMEA and **FMEDA**, (failure modes effects and diagnostic analysis), are systematic analysis technique applied in early phases of a given system development, in order to detect weak points early.

When it comes to more complex products and assemblies involving a combination of both electrical and hydraulic parts, the need to ensure that adequate surveillance over the design and manufacturing of key parts is paramount, to be compliance with the on-going series Standards **IEC 61508**.

Evaluation of the achieved performance level PL and relationship with SIL

Parts of machinery control systems that are assigned to provide safety functions are called safety-related parts of control systems and these can consist in hydraulic valves with hardware and software, and can either be separate from the machine control system or an integral part of it.

PDV units, can be requested to be applied as "logic units to ensure safety functions in accordance with Machine Directive EN 13849".

For the purpose of this part of Machine Directive, the ability of safety-related parts to perform a safety function is expressed through the determination of the performance level.

To make the assessment of the quantifiable aspects of the PL easier, this part of EN 13849 provides a simplified method based on the definition of five designated architectures that fulfil specific design criteria and behaviour under a fault condition.

Therefore, the machine builder or system integrator have full accountability for making the final products selection and assuring that all performance, safety and warning requirements of the application are being met.

PDV74 is a hydraulic proportional directional valve, designed to offer a wide range of control options and flexibility.

The **PDV74** modular system enables bankable groups to perform many individual tasks, to meet and exceed the changing control needs of the off-highway machines of today, and well into the future to maximize the efficiency, controllability and reliability of vehicles.

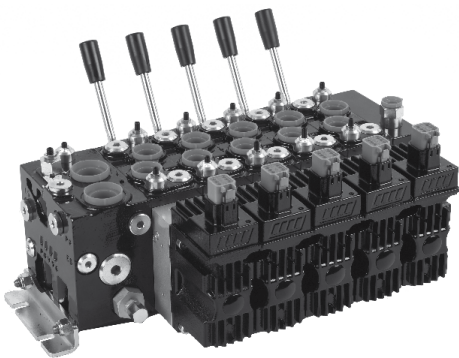
**PDV74 main features:**

- Load sensing up-stream pressure compensation
- High flow/low pressure drop capability in a compact size
- Integrated pump unloading system
- Integrated cut-off pump system
- Open/closed centre shifting system
- Precise metering capabilities
- LSA-LSB electrical unloading
- LSA-LSB electrical working pressure remote control
- Constant flow regardless of pressure
- Working sections symmetrical flow
- Optional priority inlet for steering or different priority functions
- Optional dual hydraulic pilot and electrohydraulic control
- ATEX and IECEx configuration
- CAN-Bus communication
- EMC immunity ensures high safety with regard to electro-magnetic compatibility

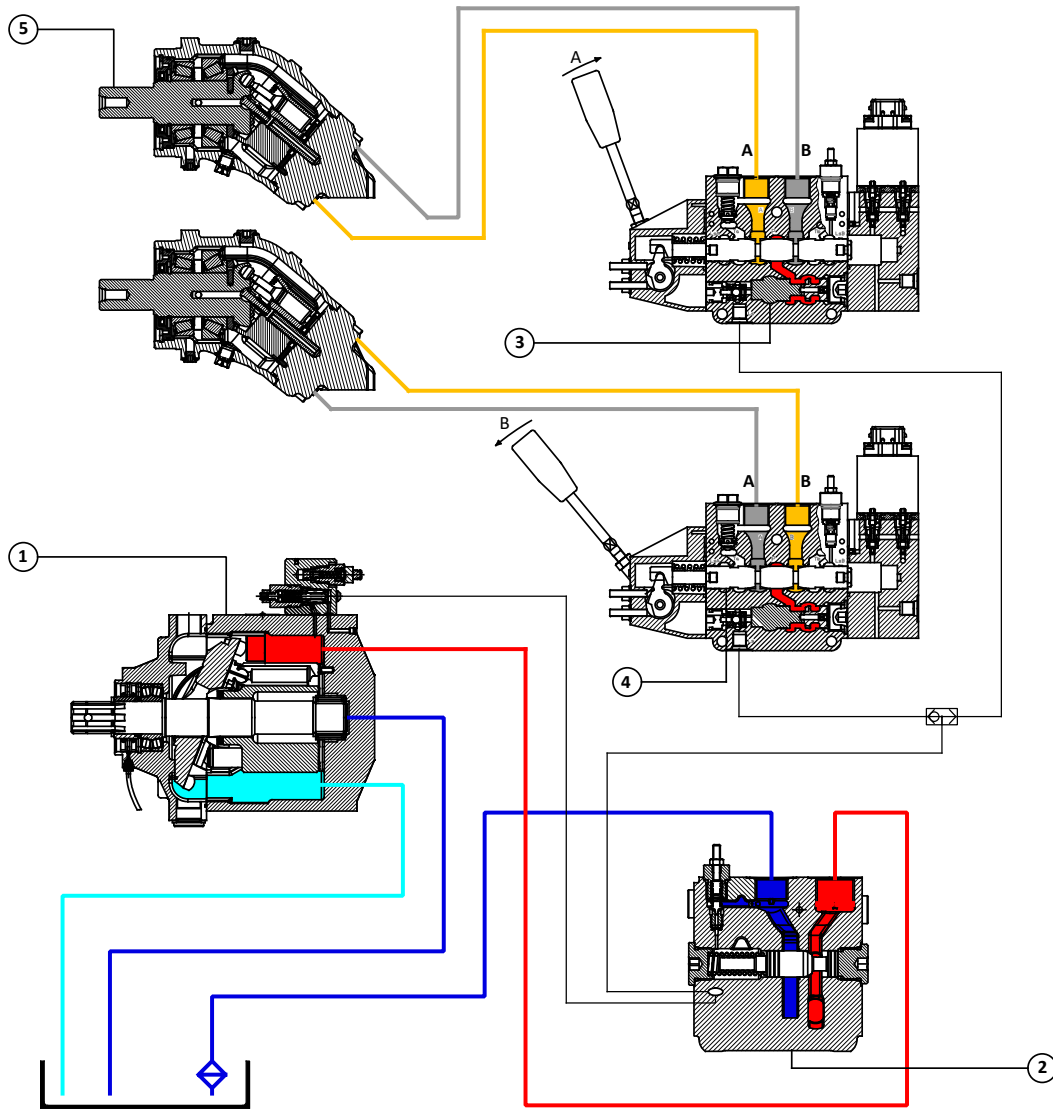

High pressure port of **PPV** piston pump ① supply the closed centre inlet section of **PDV74** proportional valve ② which in turn feeds the down-stream working sections.

The **PDS** spool neutral position ④ unload the LS pump signal to tank, so that the swashplate angle is towards the minimum displacement and pressure in stand-by setting.

The spool position determines the flow demands (speed rotation) of the two **HPM** motors ⑤.

The PDS main spool compares the pressure drop before and after the spool notches (differential pressure Δp), and therefore, the pump flow remain constant.

If the differential pressure increase, the pump swashplate is swivelled back towards the minimum displacement, and if the differential pressure decrease, the swashplate angle increase towards the max flow displacement until balance is restored within the valve.

Actuators load determines the working pressure, and the built-in pressure compensator ③ enable simultaneously function regardless of different working pressure.

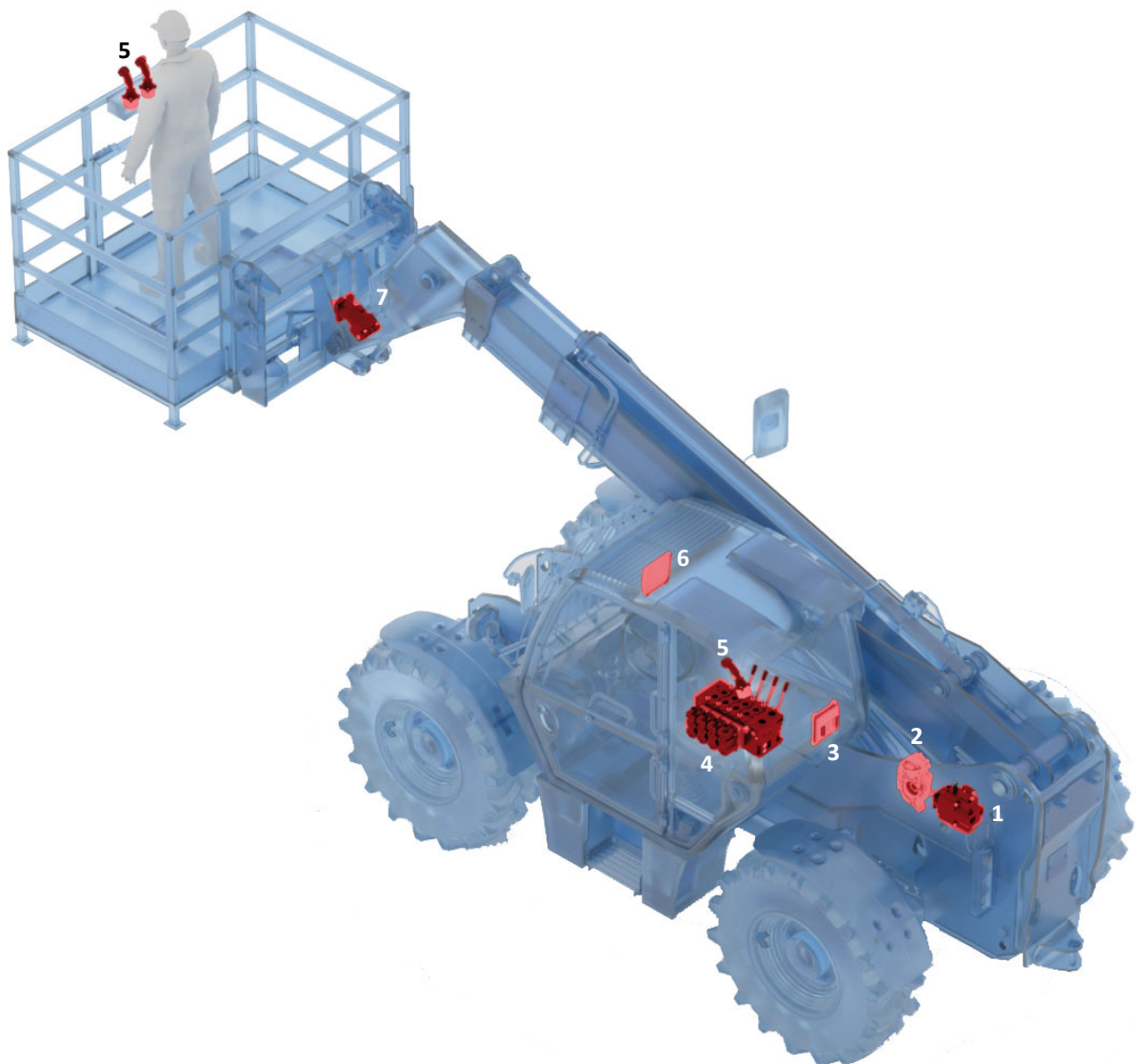

1. PPV90 load sensing piston pump
2. Pump splitter gear box
3. I/O controller PHSI7101008
4. PDV74/6 closed centre inlet
5. Electronic double axis joystick PEJD
6. Graphic display PDHI703000
7. PPM40 piston motor

The hydraulic features listed in this chart, are typical measured data obtained by using mineral based hydraulic oil according to DIN 51524 with a viscosity of 21 mm²/sec [102 SUS] and a temperature of 50 °C [122 °F]

Oil flow rate	PDI inlet section, P port		160 l/min (max)	42 US gal/min
	PDIM - Mid inlet section, P port		250 l/min	66 US gal/min
	A, B port with pressure compensator		130 l/min	34 US gal/min
	A, B port without pressure compensator		140 l/min	37 US gal/min
Max. pressure	P port	Pressure relief valve setting	400 bar	5800 psi
		Working pressure	370 bar	5370 psi
	A, B port		370 bar	5370 psi
	Ty port, directly to tank			
	T port	Static	25 bar	363 psi
Dynamic		37 bar	537 psi	
Max. pilot pressure oil supply			18 ÷ 22 bar	260 ÷ 320 psi
Oil temperature	Recommended		30 ÷ 65 °C	86 °F ÷ 149 °F
	Min		-30 °C	-22 °F
	Max		90 °C	194 °F
Ambient temperature			-30 ÷ 60 °C	-22 ÷ 140 °F
Oil viscosity	Operating range		12 ÷ 75 mm ² /sec	65 ÷ 347 SUS
	Min		4 mm ² /sec	39 SUS
	Max		460 mm ² /sec	2128 SUS
Spool stroke	Standard		7 mm	0,28 in
	Flow control proportional range		5,5 mm	0,22 in
	Pressure control propotional range		7 mm	0,28 in
Daed band spool	Flow control		1,5 mm	0,06 in
	Pressure control		1,5 mm	0,06 in
Max internal leakage A/B port at 100 bar [1450 psi] and 21 mm ² /sec		A/B T without shock valves	21 cm ³ /min	1,28 in ³ /min
		A/B T with shock valves	25 cm ³ /min	1,53 in ³ /min
Filtration	Max. contamination: class 9 according to NAS 1638 (20/18/15 according to ISO 4406)			

PDH module - hydraulic control

Pilot pressure	Spool start movement	4 bar / 58 psi
	Spool end stroke	15 bar / 218 psi
Max. pilot pressure		30 bar / 436 psi

PDV74 internal filters, mesh 100 µm

Mineral oil hydraulic fluid: according to DIN 51524 and 51525 or ISO 6743/4 PDV74 can also be used with phosphate esters (HFDR), water-glycol (HFC) or water oil (HFB) mixes, subject to our Technical Dept. approval

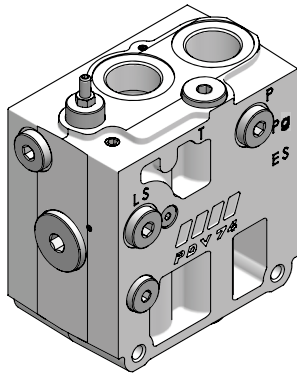

Hydraulic diagram

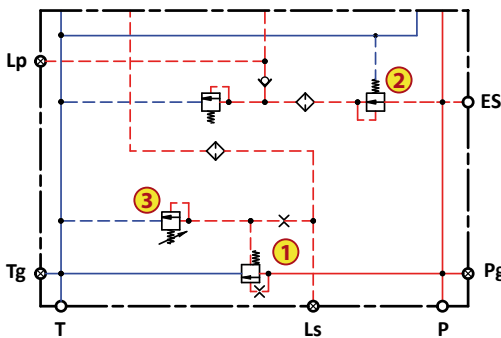

Designed for use with fixed displacement pumps.

Inlet comes standard with pressure compensated 3-way flow regulator (1), that when pump is started and working sections spools are in neutral position, it's unloaded to tank, and the oil flow being supplied from the pump, passes through the 3-way flow regulator to tank with minimal off-load pressure drop (see diagram below).

When one or more of the spools are actuated, the highest working pressure signal is fed to the 3-way flow regulator, that maintains the Δp at a constant level, so that the flow rate is independent of the load, and proportional to the opened spool area. The built in pressure reducing valve (2), act as the pilot pressure supply for the electrical actuators, as well as, the hydraulic remote controls.

When the main PDS spools are actuated, the exceeding pump flow is being sent to tank at the highest load pressure value. If the working pressure reaches the setting of the upstream max pressure pilot relief valve (3), the 3-way flow regulator will be opened to tank, thus limiting the working pressure inside the complete PDV.

On this configuration, the level of safety degrees for the complete PDV valve is really low, therefore, operator's great supervision is strictly request.

Neutral flow-pressure drop in PDI, open centre

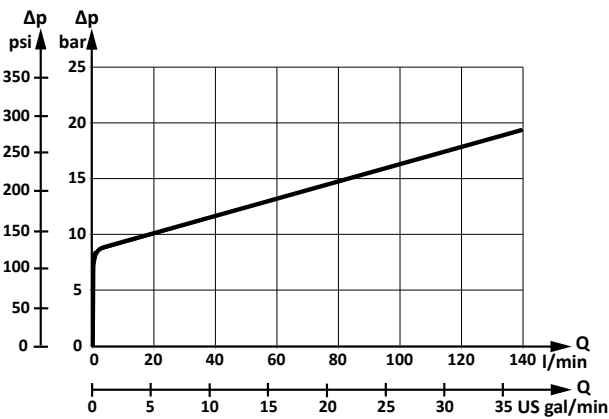

Pressure relief valve characteristic in PDI, open centre

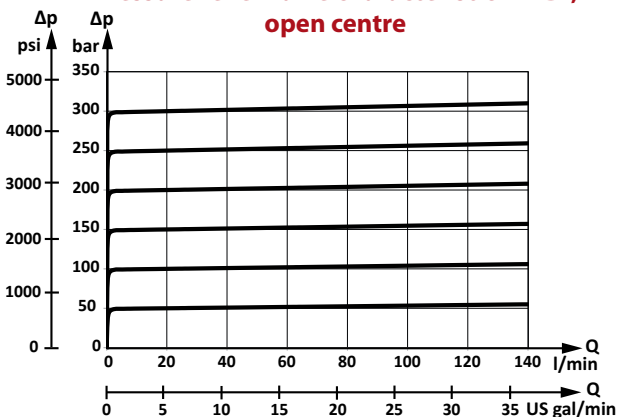

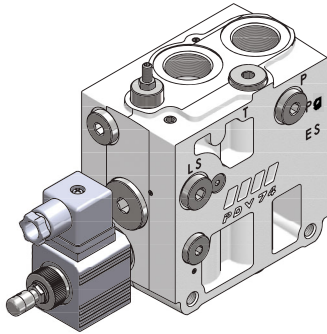

Hydraulic diagram

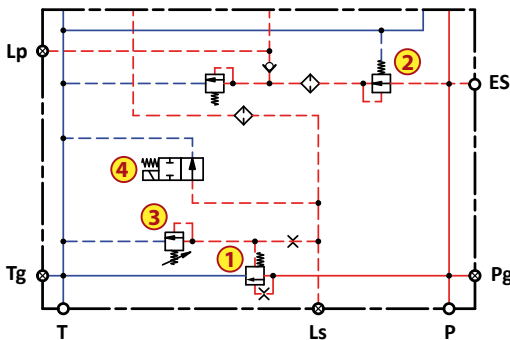

Neutral flow-pressure drop in PDI, open centre

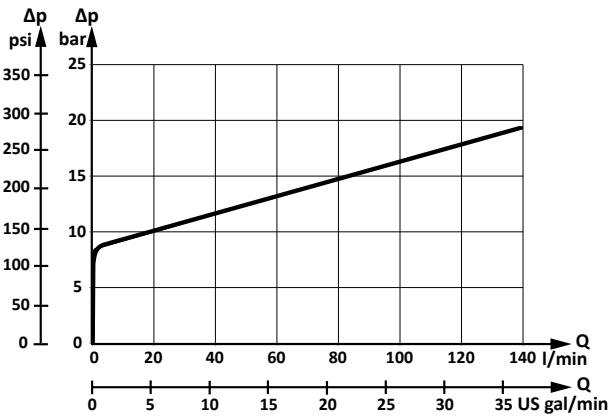

Pressure relief valve characteristic in PDI, open centre

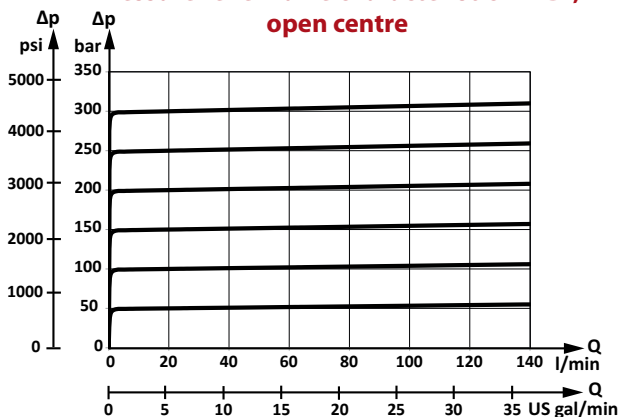

Designed for use with fixed displacement pumps.

Inlet comes standard with pressure compensated 3-way flow regulator ①, that when pump is started and working sections spools are in neutral position, it's unloaded to tank, and the oil flow being supplied from the pump, passes through the 3-way flow regulator to tank with minimal off-load pressure drop (see diagram below).

When one or more of the spools are actuated, the highest working pressure signal is fed to the 3-way flow regulator, that maintains the Δp at a constant level, so that the flow rate is independent of the load, and proportional to the opened spool area. The built in pressure reducing valve ②, act as the pilot pressure supply for the electrical actuators, as well as, the hydraulic remote controls.

When the main PDS spools are actuated, the exceeding pump flow is being sent to tank at the highest load pressure value. If the working pressure reaches the setting of the upstream max pressure pilot relief valve ③, the 3-way flow regulator will be opened to tank, thus limiting the working pressure inside the complete PDV.

According to an electrical signal coming from the remote controls or I/O controller, the PDU solenoid unloading valve ④, enable the LS signal to be relieved to tank, and the effect of this configuration is an almost pressureless system, where the activated actuators will be automatically catted off. The pressure in the system will be reduced to the sum of the tank port pressure, plus the neutral flow pressure drop through the 3-way flow regulator.

Care must be given, because all the actuators whose working pressure is lower than the pressure drop through the 3-way regulator, might be still operated.

Also with the use of PDU emergency solenoid unloading valve, the level of safety degrees for the complete PDV valve is quite low, therefore, operator's supervision is required.

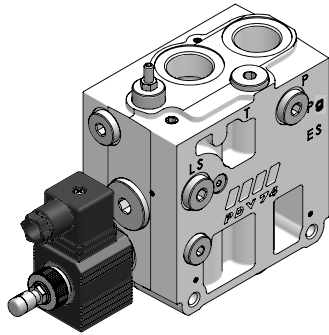

Hydraulic diagram

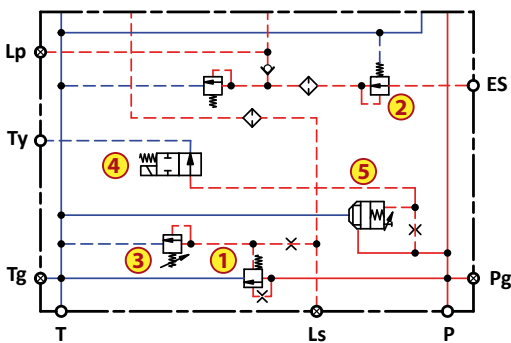

Designed for use with fixed displacement pumps.

Inlet comes standard with pressure compensated 3-way flow regulator ①, that when pump is started and working sections spools are in neutral position, it's unloaded to tank, and the oil flow being supplied from the pump, passes through the 3-way flow regulator to tank with minimal off-load pressure drop (see diagram below).

When one or more of the spools are actuated, the highest working pressure signal is fed to the 3-way flow regulator, that maintains the Δp at a constant level, so that the flow rate is independent of the load, and proportional to the opened spool area. The built in pressure reducing valve ②, act as the pilot pressure supply for the electrical actuators, as well as, the hydraulic remote controls.

When the main PDS spools are actuated, the exceeding pump flow is being sent to tank at the highest load pressure value. If the working pressure reaches the setting of the upstream max pressure pilot relief valve ③, the 3-way flow regulator will be opened to tank, thus limiting the working pressure inside the complete PDV.

By means of an electrical signal coming from the remote controls or I/O controller, the PDU solenoid valve ④, operates the poppet type pilot operated valve ⑤, which in turn, allows the full flow coming from the pump to be relieved to tank, bypassing the 3-way flow regulator ①.

The effect of this condition is a complete and safely pressureless system, where all actuators will be automatically catted-off, and the pressure into the system will be reduced to the sum of the tank port pressure, plus the pressure drop through the poppet unloading valve (see characteristic curve below)

When the inlet section comes with this configuration and the pump unloading system is connected with the active fault monitoring spool actuators, the level of safety degree protection for the complete hydraulic system becomes very high, operator free, and helps OEM to meet the PL (Performance Level) required to be comply with the safety demands of Machinery Directive 2006/42/EC.

Neutral flow-pressure drop in PDI, open centre

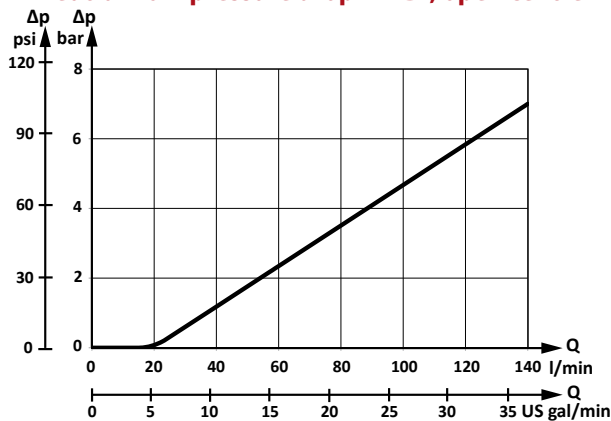

Pressure relief valve characteristic in PDI, open centre

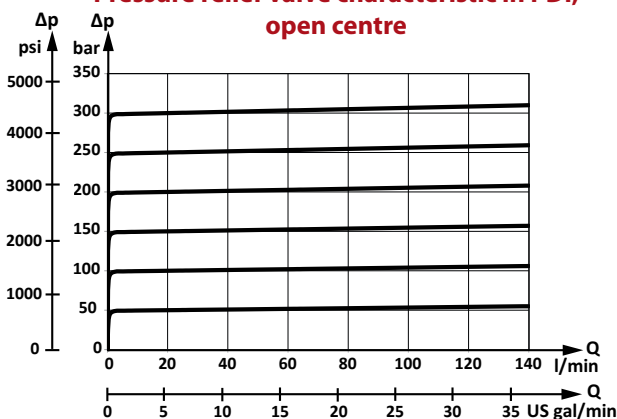

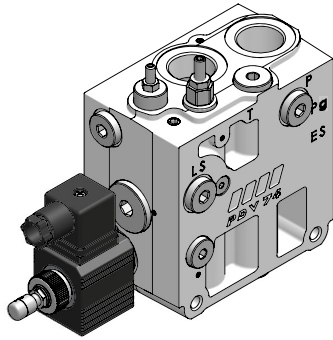

Hydraulic diagram

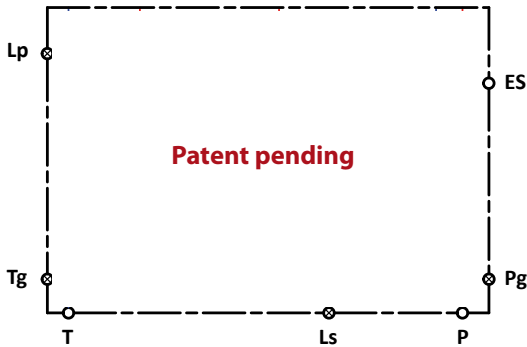

Designed to be configured either as open centre (fixed displacement pumps) or closed centre version (variable displacement pumps)

Inlet comes standard with pressure compensated 3-way flow regulator ①, that when pump is started and working sections spools are in neutral position, it's unloaded to tank, and the oil flow being supplied from the pump, passes through the 3-way flow regulator to tank with minimal off-load pressure drop (see diagram below).

When one or more of the spools are actuated, the highest working pressure signal is fed to the 3-way flow regulator, that maintains the Δp at a constant level, so that the flow rate is independent of the load, and proportional to the opened spool area. The built in pressure reducing valve ②, act as the pilot pressure supply for the electrical actuators, as well as, the hydraulic remote controls.

When the main PDS spools are actuated, the exceeding pump flow is being sent to tank at the highest load pressure value. If the working pressure reaches the setting of the upstream max pressure pilot relief valve ③, the 3-way flow regulator will be opened to tank, thus limiting the working pressure inside the complete PDV.

By acting clockwise on the pilot shifting spool ④, without changing any components, the inlet section circuit will be transformed into closed centre configuration.

In this configuration the load sensing pilot pressure is led to pump control via the LS connection. When a main spool is actuated, the pump regulator will adjust the displacement so that the set differential pressure (stand-by pressure) between P and LS signal is maintained.

The pressure relief valve 3 is to be set at 35 bar above maximum cut-off pressure set on the pump.

The LS control performs as a constant pressure control also, decreasing pump displacement when system pressure reaches the PC setting.

The pressure compensating function has the priority over the load sensing function.

Neutral flow-pressure drop in PDI, open centre

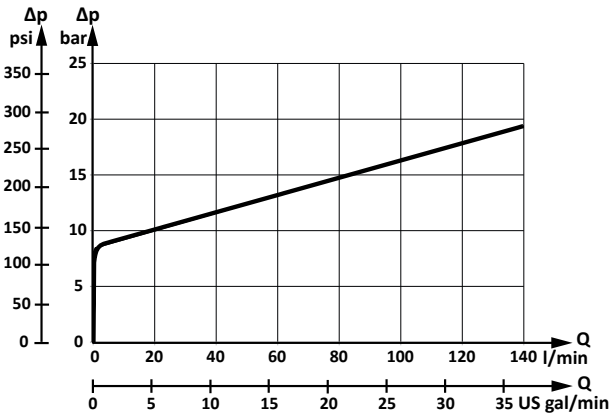

Pressure relief valve characteristic in PDI, open centre

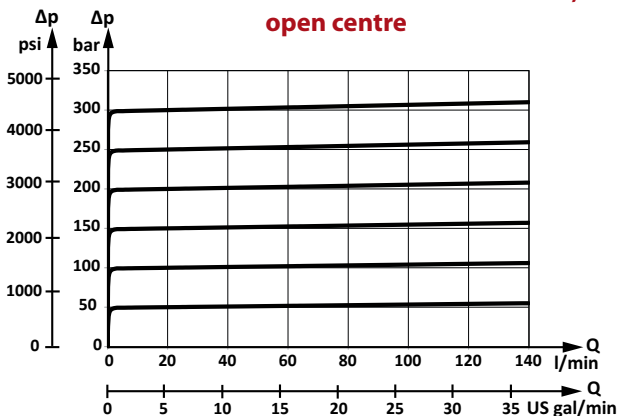

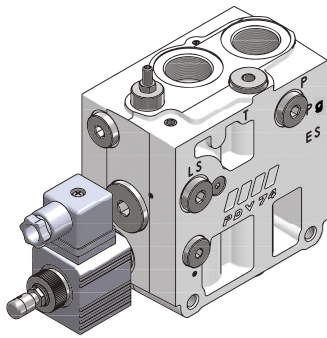

Hydraulic diagram

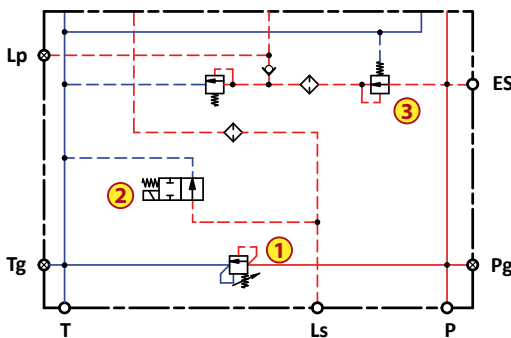

Pressure relief valve characteristic in PDI, open centre

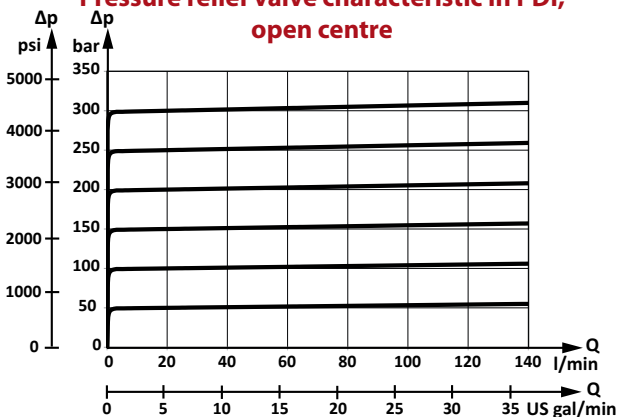

Designed for use with LS variable displacement pumps.

Inlet comes standard without pressure compensated 3-way flow regulator.

When pump is started and PDV spools are in neutral position, the LS pump signal is unloaded to tank.

When one or more of the spools are actuated, the highest signal is sent to the pump regulator that control the pump swashplate angle.

The PDS main spool compares the pressure drop before and after the spool notches (differential pressure Δp), and therefore, the pump flow remain constant.

The position of the PDS spool determines the flow demand. If the differential pressure increase, the pump swashplate is swivelled back towards the minimum displacement, and if the differential pressure decrease, the swashplate angle increase towards the max flow displacement until balance is restored within the valve.

The inlet section can comes with an optional pressure relief valve ① that should be set at pressure about 35 bar above maximum system pressure set on the pump regulator.

According to an electrical signal coming from the remote controls or I/O controller, the PIU solenoid unloading valve ② enable the LS signal to be relieved to tank.

The effect of this configuration is an almost pressureless system, where the activated actuators will be automatically catted off, and the pressure in the system will be reduced to the sum of the tank port pressure, plus the differential pressure of the pump, therefore, care must be given, because all the actuators whose working pressure is lower than the remaining pressure might be still operated.

The built in pressure reducing valve ③, act as the pilot pressure supply for the electrical actuators, as well as, the hydraulic remote controls.

Also with the use of PIU emergency solenoid unloading valve, the level of safety degrees for the complete PDV valve is quite low, therefore, operator's great supervision is required.

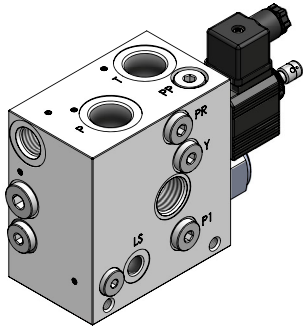

Hydraulic diagram

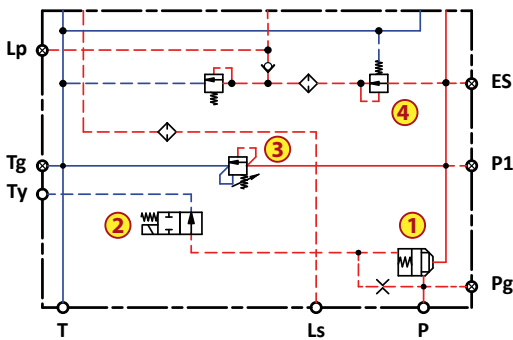

Pressure drop cut-off system in PDI, closed centre

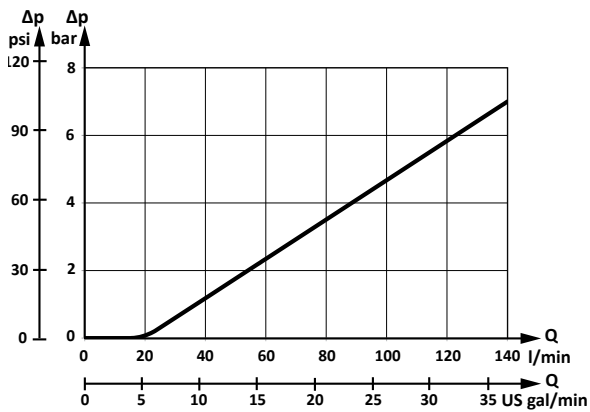

Pressure relief valve characteristic in PDI, closed centre

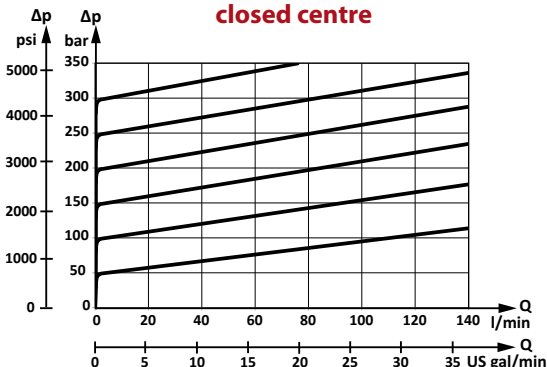

Designed for use with LS variable displacement pumps.

This version of inlet comes standard with a double stage cut-off pump system ①, that when activated according to an electrical signal ②, all down-stream working section will be perfectly and safely sealed from pressure and flow, protecting the complete hydraulic machines control against the negative effect of the remaining stand by pressure.

Inlet comes standard without pressure compensated 3-way flow regulator.

When pump is started and PDV spools are in neutral position, the LS pump signal is unloaded to tank.

When one or more of the spools are actuated, the highest signal is sent to the pump regulator that control the pump swashplate angle.

The PDS main spool compares the pressure drop before and after the spool notches (differential pressure Δp), and therefore, the pump flow remain constant.

The position of the PDS spool determines the flow demand. If the differential pressure increase, the pump swashplate is swivelled back towards the minimum displacement, and if the differential pressure decrease, the swashplate angle increase towards the max flow displacement until balance is restored within the valve.

The inlet section can comes with an optional pressure relief valve ③ that should be set at pressure about 35 bar above maximum system pressure set on the pump regulator.

The built in pressure reducing valve ④, act as the pilot pressure supply for the electrical actuators, as well as, the hydraulic remote controls.

When the inlet section comes with this configuration and the cut-off pump system is connected with the active fault monitoring spool actuators, the level of safety degree protection for the complete hydraulic system becomes very high, operator free, and helps OEM to meet the PL (Performance Level) required to be comply with the safety demands of Machinery Directive 2006/42/EC.

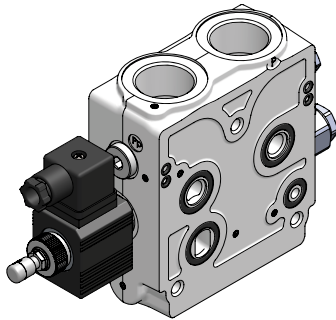

Hydraulic diagram

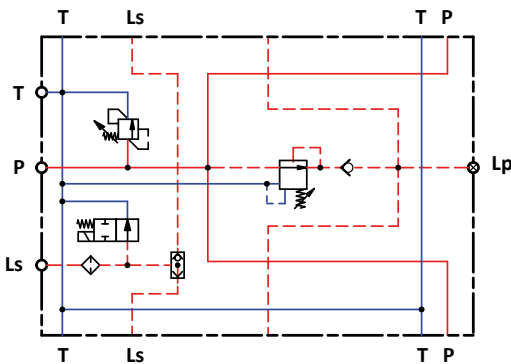

Pressure relief valve characteristic in PDI, closed centre

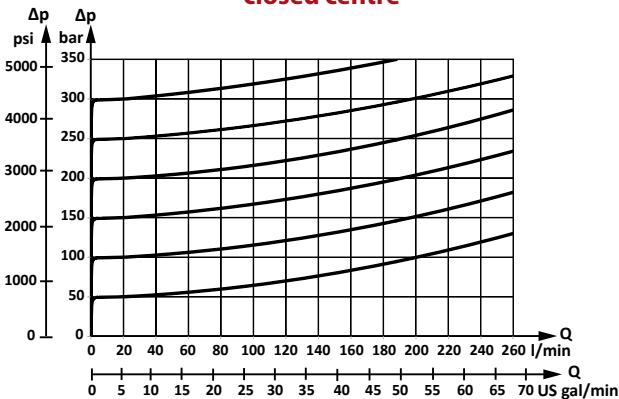

Designed for use with LS variable displacement pumps.

PDIM is a MID inlet section that allows the PDV74 to be supplied with a larger variable pump flow capacity with a lower pressure drop.

PDIM enable to PDW to be mounted on both sides of the pump side module, therefore, the PDW fitted on PMID left side, the A-B work port position are reversed.

Inlet comes standard without pressure compensated 3-way flow regulator.

When pump is started and PDV spools are in neutral position, the LS pump signal is unloaded to tank.

When one or more of the spools are actuated, the highest signal is sent to the pump regulator that control the pump swashplate angle.

The PDS main spool compares the pressure drop before and after the spool notches (differential pressure Δp), and therefore, the pump flow remain constant.

The position of the PDS spool determines the flow demand. If the differential pressure increase, the pump swashplate is swivelled back towards the minimum displacement, and if the differential pressure decrease, the swashplate angle increase towards the max flow displacement until balance is restored within the valve.

The inlet section may comes with an optional pressure relief valve that should be set at pressure about 35 bar above maximum system pressure set on the pump regulator.

According to an electrical signal coming from the remote controls or I/O controller, the PIU solenoid unloading valve enable the LS signal to be relieved to tank.

The effect of this configuration is an almost pressureless system, where the activated actuators will be automatically catted off, and the pressure in the system will be reduced to the sum of the tank port pressure, plus the differential pressure of the pump, therefore, care must be given, because all the actuators whose working pressure is lower than the remaining pressure might be still operated.

Also with the use of PIU emergency solenoid unloading valve, the level of safety degrees for the complete PDV valve is quite low, therefore, operator's great supervision is required.

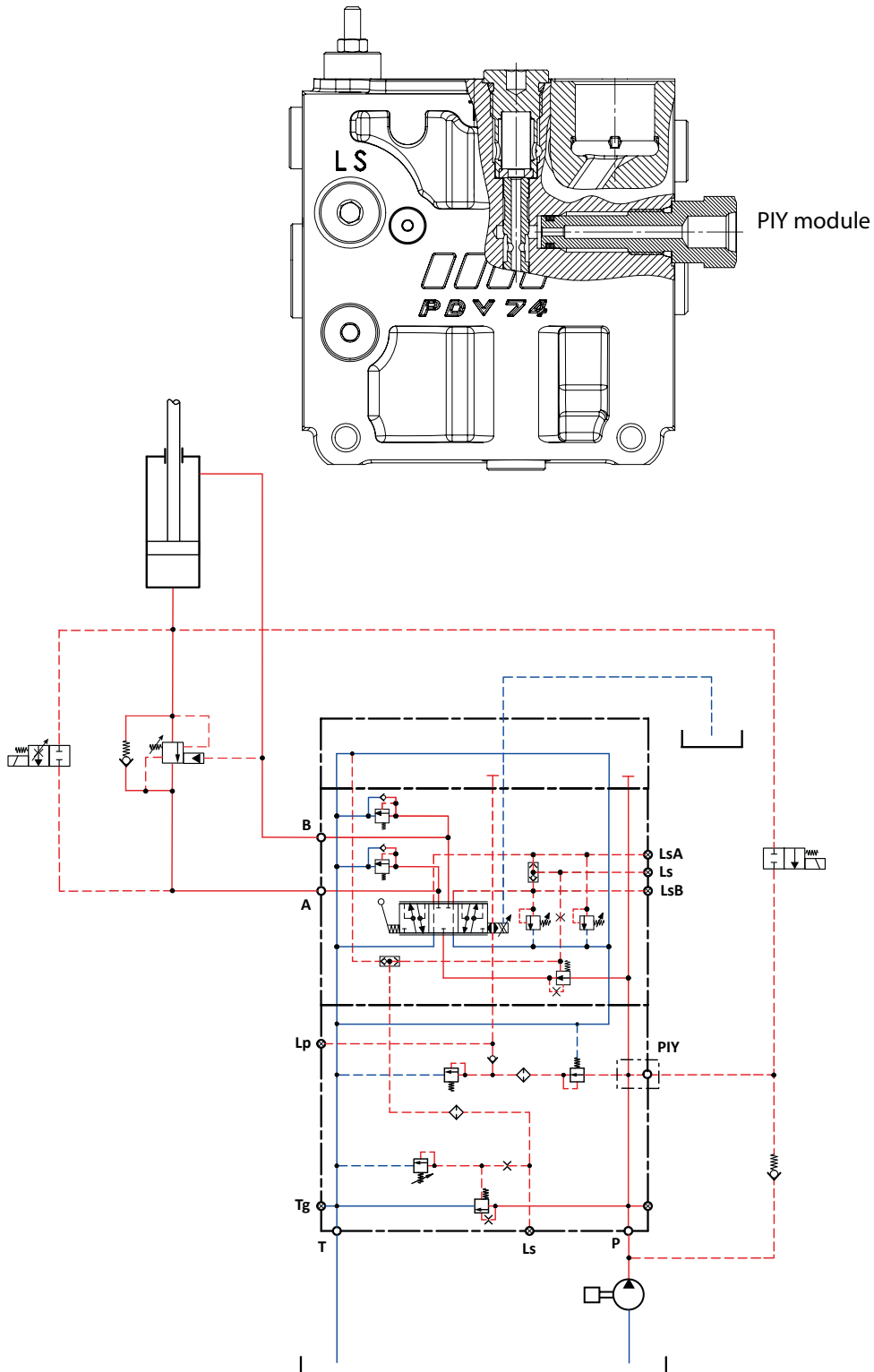

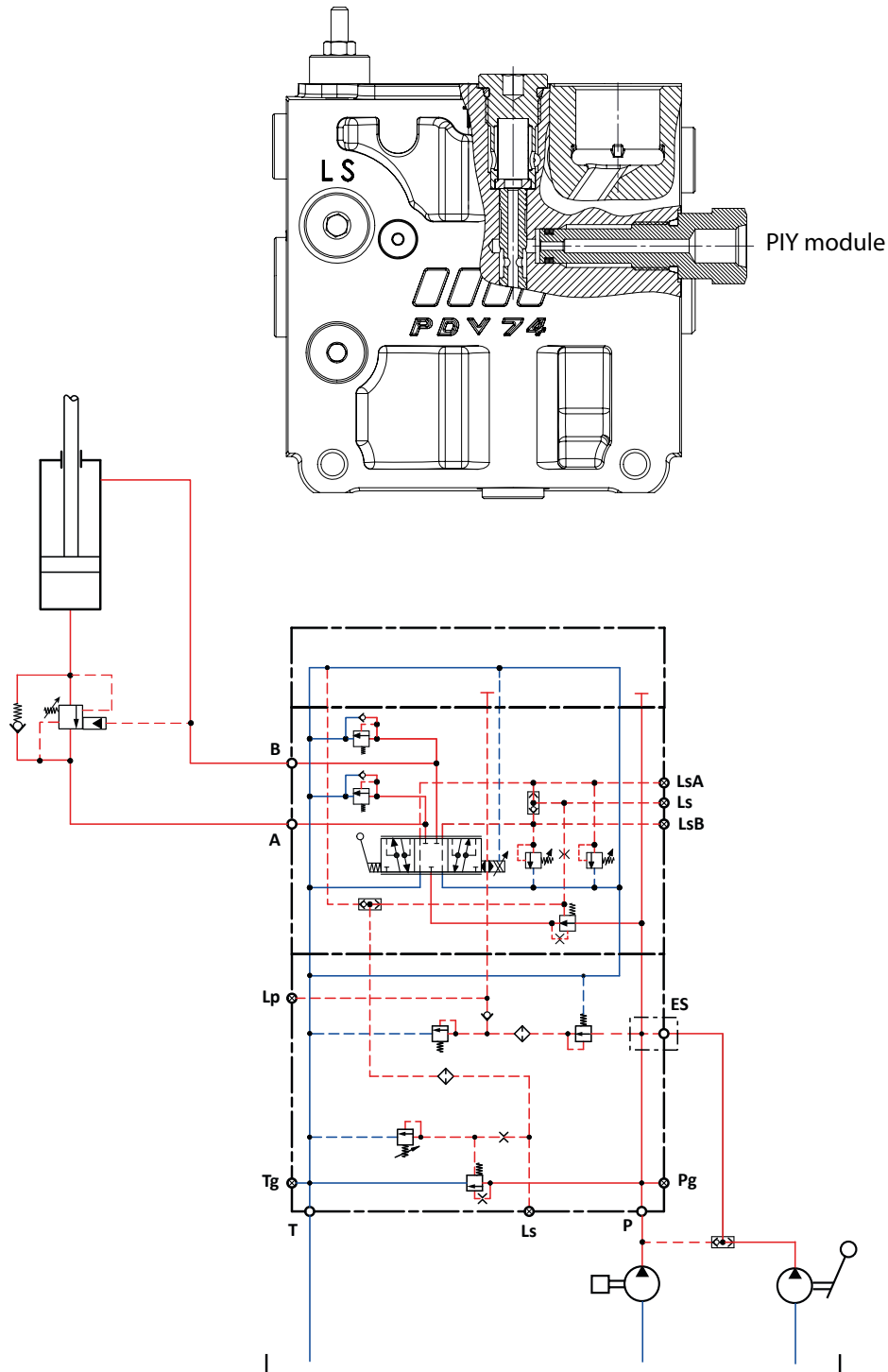

This inlet configuration (for open or closed centre) is suited to supply the PDV74 with a flow from an auxiliary manual operated emergency pump.

Normally the main pump supply the built in pressure reducing valve through the PIY, screw-in cartridge.

In case of main pump failure, the external shuttle valve ensure that the main pressure reducing valve is being supplied from the emergency hand pump, and the pilot oil supply available for electric actuators.

Product

Hydraulic diagram

Description

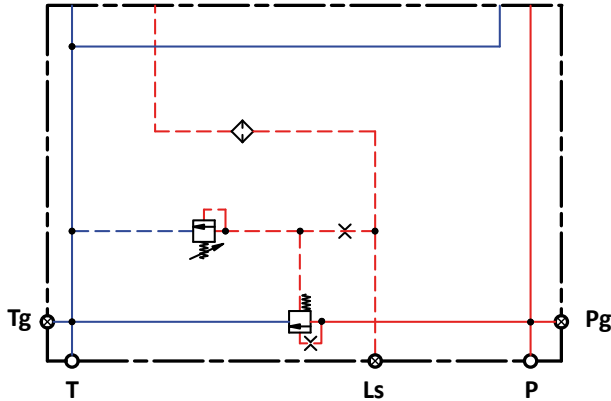
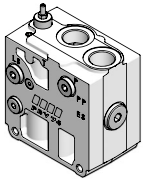

For mechanically actuated valves, only

Code numbers

PDI07A30000

PDI07A30010

BSP

UN-UNF

P, T ports 3/4"
Ls, Pg, Tg ports 1/4"

P, T ports 1 1/16"-12UN-2B
Ls, Pg, Tg ports 7/16"-20UNF-2B

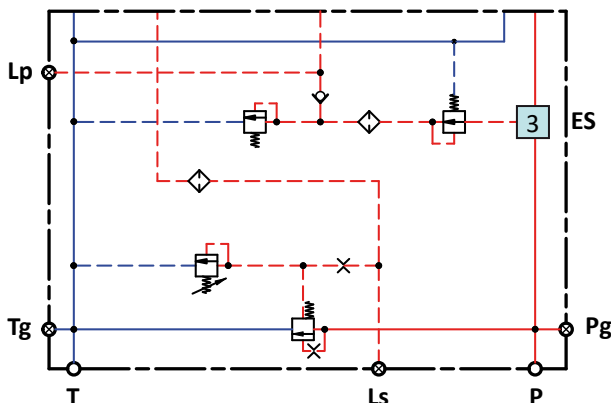
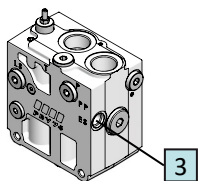

With pilot oil supply for electrically and hydraulically actuated valves **3**

Code numbers

PDI07A40000

PDI07A40010

BSP

UN-UNF

Connections threads see page [113](#)

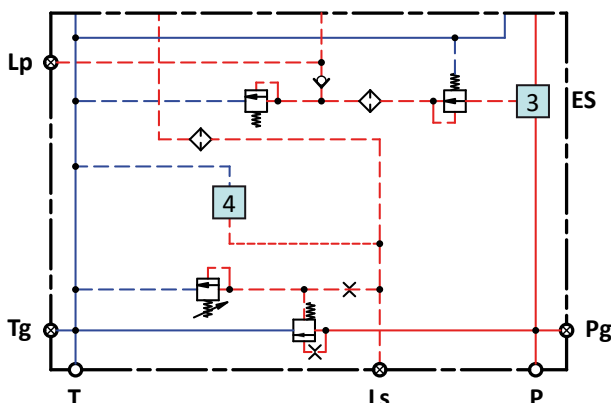
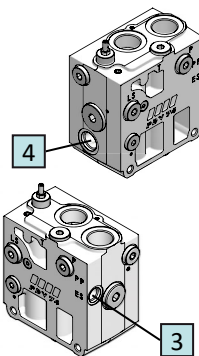

With pilot oil supply for electrically and hydraulically actuated valves **3** and facility for LS unloading **4**

Code numbers

PDI07A41000

PDI07A41010

BSP

UN-UNF

Connections threads see page [113](#)

Product

Hydraulic diagram

Description

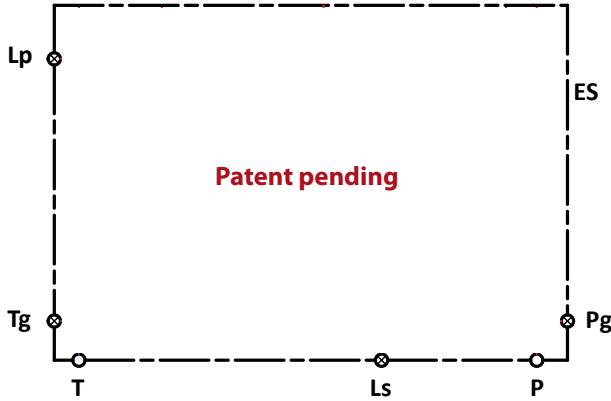
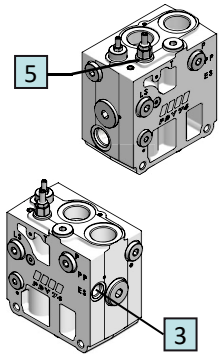

With pilot oil supply, for electrically and hydraulic actuated valves **3** and shifting pump system **5**

Code numbers	
PDI07B40000	PDI07B40010
BSP	UN-UNF
Connections threads see page 113	

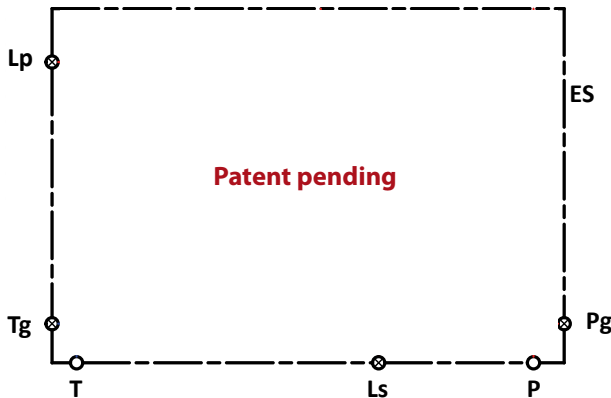
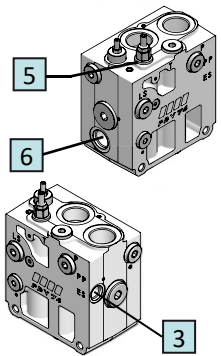

With pilot oil supply for electrically and hydraulic actuated valves **5**, shifting pump system **6** and facility for LS unloading **3**

Code numbers	
PDI07B41000	PDI07B41010
BSP	UN-UNF
Connections threads see page 113	

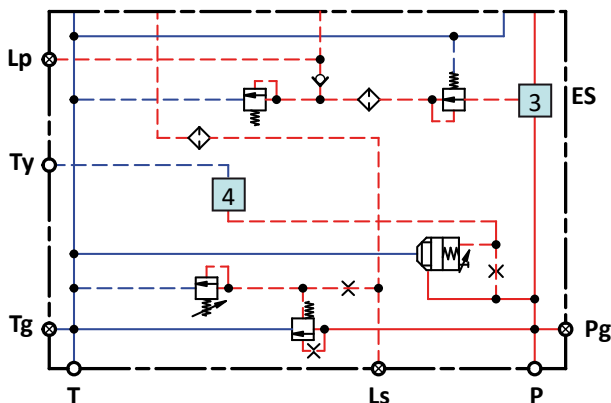
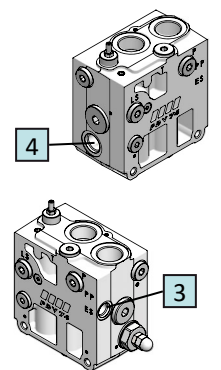

With pilot oil supply for electrically and hydraulic actuated valves **3** and pump unloading system **4** with external drain line

Code numbers	
PDI07A42000	PDI07A42010
BSP	UN-UNF
Connections threads see page 113	

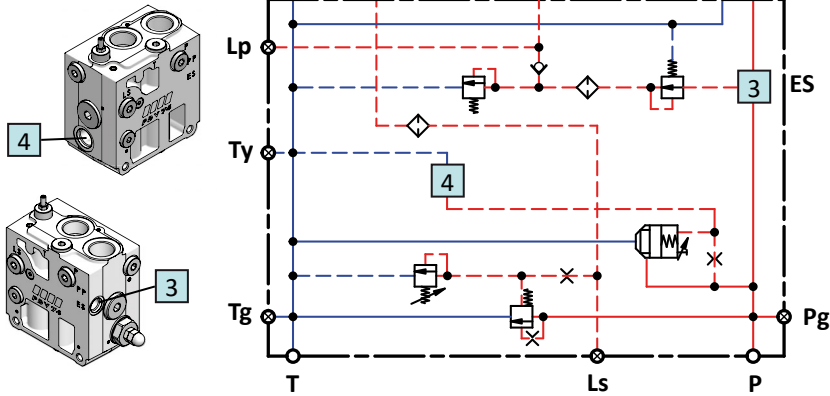

With pilot oil supply for electrically and hydraulically actuated valves **3** and pump unloading system **4** with internal drain line

Code numbers

PDI07A45000

PDI07A45010

BSPP

UN-UNF

Connections threads see page [113](#)

Product

Hydraulic diagram

Description

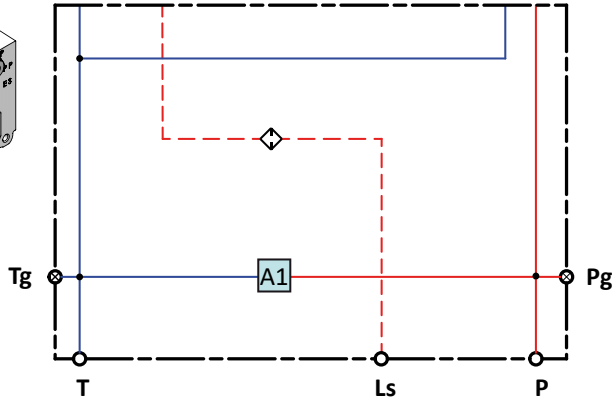
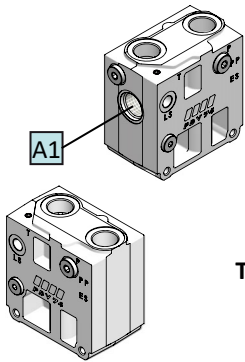

For mechanically actuated valves, prearranged for pressure relief valve **A**

Code numbers	
PDI07C3000	PDI07C30010
BSP	UN-UNF
Connections threads see page 113	

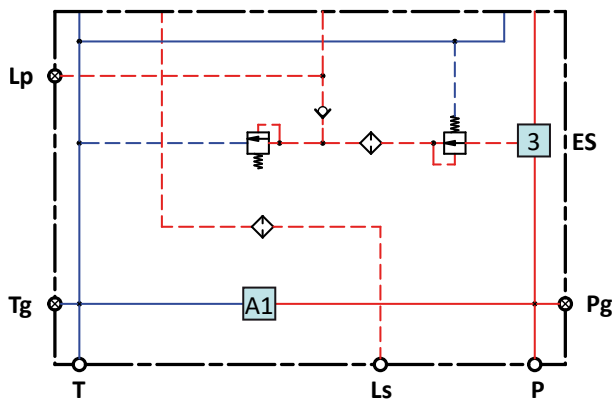
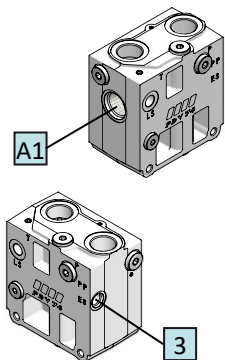

With pilot oil supply for electrically and hydraulic actuated valves **3** prearranged for pressure relief valve **A**

Code numbers	
PDI07C4000	PDI07C40010
BSP	UN-UNF
Connections threads see page 113	

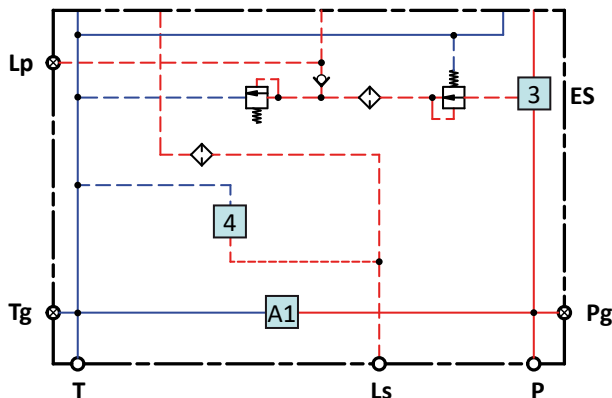
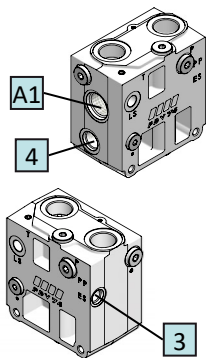

With pilot oil supply for electrically and hydraulic actuated valves **3** prearranged for LS unloading **4** and pressure relief valve **A**

Code numbers	
PDI07C4100	PDI07C41010
BSP	UN-UNF
Connections threads see page 113	

Product

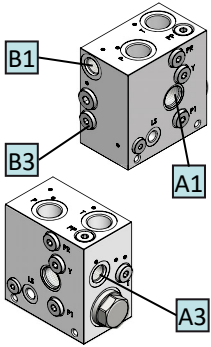

Hydraulic diagram

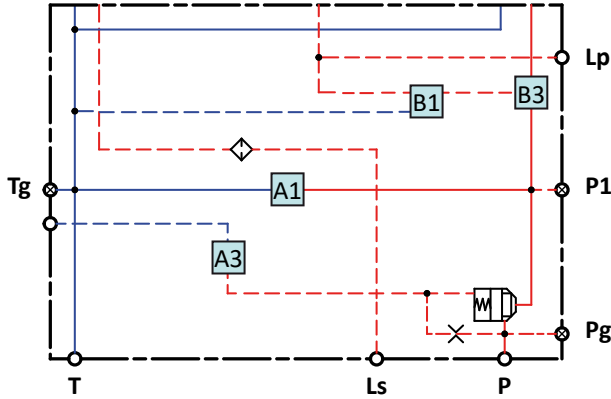

Description

With pilot pressure oil supply for electrically and hydraulic actuated valves **B3**, and cut-off pump system **A3** prearranged for pressure relief valve **A1**

Code numbers

PDIO7C44000

PDIO7C44010

BSP

UN-UNF

Connections threads see page [113](#)

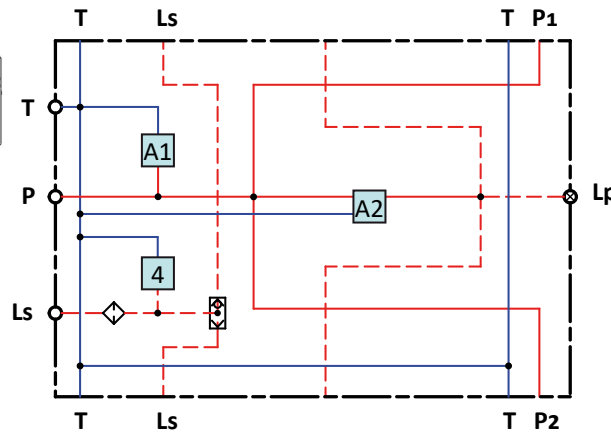
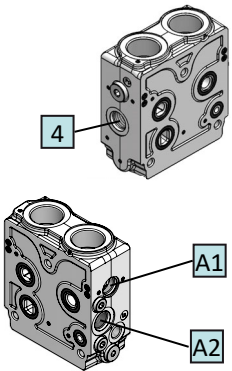

PDV74 MID inlet with pilot oil supply for electrically and hydraulic actuated valves, facility for LS unloading **4** and prearranged for pressure relief valve **A1**

Code numbers

PDIM7C41000

PDIM7C41010

BSP

UN-UNF

Connections threads see page [127](#)

DIN 43650A

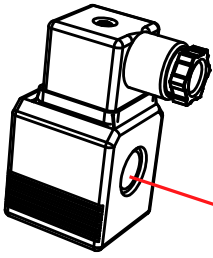

Deutsch Parallel

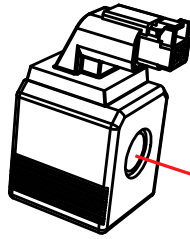

Deutsch Perpendicular

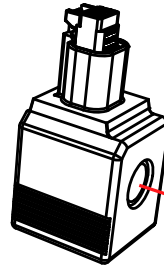

Junior Power Timer

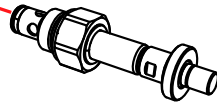
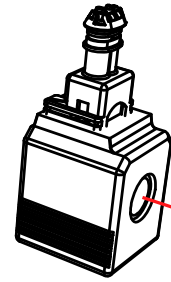

Normally closed
 Emergency: screw

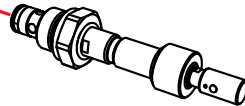



Normally open
 Emergency: push and twist

Code numbers

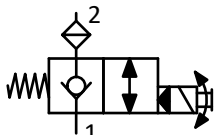
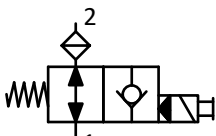
PIU solenoid LS unloading valve codes

Code numbers			
PIU solenoid LS unloading valve codes			
Cartridge valve type	Connector type	12 Vdc	24 Vdc
Normally closed Emergency: screw 	DIN 43650A	PIU0C023200	PIU0C013200
	Deutsch Parallel	PIU0C021200	PIU0C011200
	Deutsch Perpendicular	PIU0C022200	PIU0C012200
	Junior Power Timer	PIU0C024200	PIU0C014200
Normally open Emergency: push and twist 	DIN 43650A	PIU0A023100	PIU0A013100
	Deutsch Parallel	PIU0A021100	PIU0A011100
	Deutsch Perpendicular	PIU0A022100	PIU0A012100
	Junior Power Timer	PIU0A024100	PIU0A014100

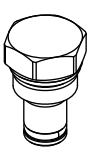
Plug for LS unloading cavity

Plug cavity	Hydraulic scheme	Code numbers
		<p>PIP10000000</p>

Max. operating pressure	350 bar	
Max. internal leakage	350 bar, 46 mm²/sec 1 cm³/min	
max pressure drop	< 1,5 bar	
Expected life - 350 bar, 0,5 Hz (1s on / 1s off)	10.000.000 cycles	
Response time for LS pressure relief	< 280ms	
Oil temperature	Recommended	30 ÷ 60 °C
	Min.	-30 °C
	Max.	90 °C
Ambient temperature	-30 ÷ 60 °C	
Max. coil surface temperature	160 °C	
Oil viscosity	Operating range	10 ÷ 90 cSt
	Min.	4 mm²/sec
	Max.	460 mm²/sec
Degree of enclosure	Connector DIN 43650	IP65
	Connector Deutsch DT04-2p	IP67
		IP69K integrated to coil
Rated voltage	12 Vdc	24 Vdc
Supply voltage	10,6 ÷ 14,6 Vdc	20,4 ÷ 28,6 Vdc
Working temperature	-30 ÷ 80 °C	
Maximum coil surface temperature	175 °C	
Heat insulation	Class H (180 °C)	
Resistance	7,5 Ω	29,9 Ω
Current consumption	1,6 A	0,8 A
Power consumption	19 W	

Product

Hydraulic diagram

Description

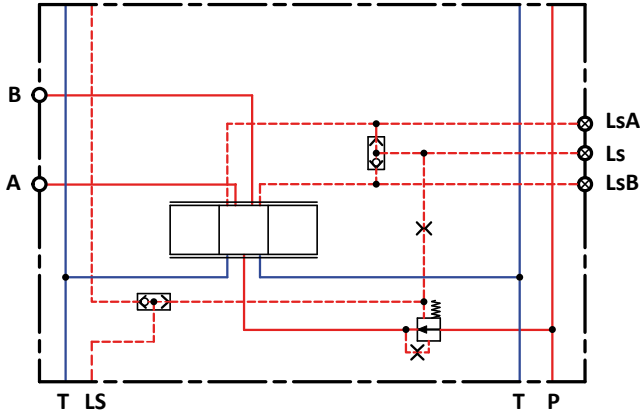
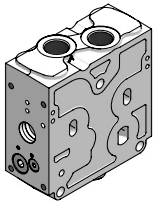

<p>No facilities for shock-suction valves No facilities for LS A/B pilot relief valves</p>	
Code numbers	
PDW71000000	PDW71000010
BSP	UN-UNF
A/B ports 1/2" Ls-LsA-LsB remote pressure connections 1/4"	A/B ports 7/8"-14UNF-2B Ls-LsA-LsB remote pressure connections 7/16"-20UNF-2B

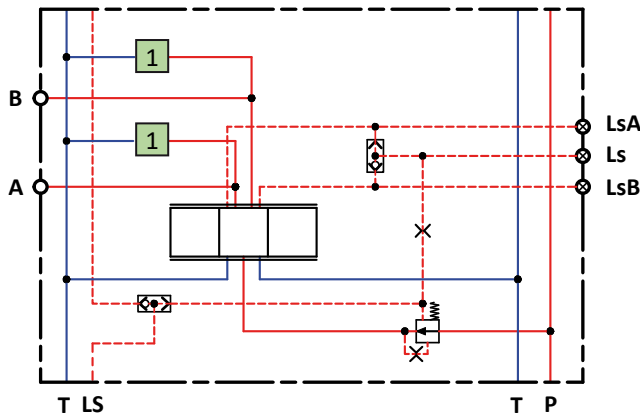
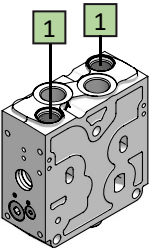

<p>Facilities for shock-suction valves 1 No facilities for LS A/B pilot relief valves</p>	
Code numbers	
PDW71010000	PDW71010010
BSP	UN-UNF
A/B ports 1/2" Ls-LsA-LsB remote pressure connections 1/4"	A/B ports 7/8"-14UNF-2B Ls-LsA-LsB remote pressure connections 7/16"-20UNF-2B

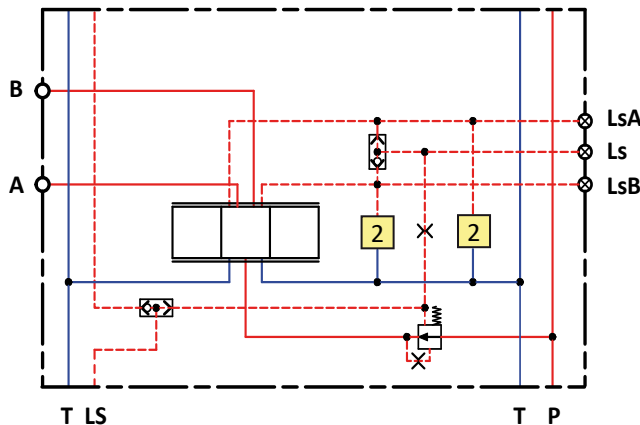
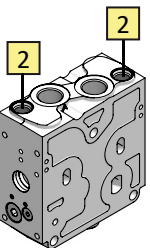

<p>No facilities for shock-suction valves Facilities for LS A/B pilot relief valves 2</p>	
Code numbers	
PDW71100000	PDW71100010
BSP	UN-UNF
A/B ports 1/2" Ls-LsA-LsB remote pressure connections 1/4"	A/B ports 7/8"-14UNF-2B Ls-LsA-LsB remote pressure connections 7/16"-20UNF-2B

Product

Hydraulic diagram

Description

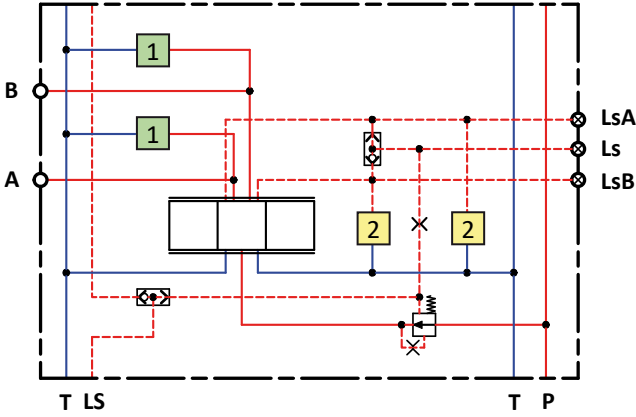
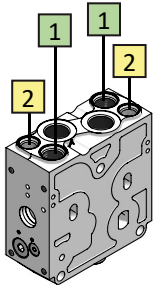

Facilities for shock-suction valves 1	
Facilities for LS A/B pilot relief valves 2	
Code numbers	
PDW71110000	PDW71110010
BSP	UN-UNF
A/B ports 1/2" Ls-LsA-LsB remote pressure connections 1/4"	A/B ports 7/8"-14UNF-2B Ls-LsA-LsB remote pressure connections 7/16"-20UNF-2B

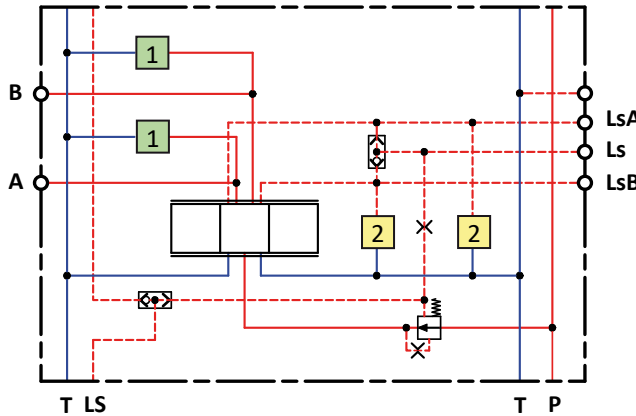
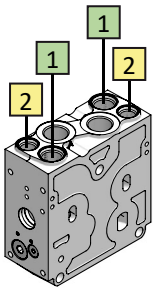

Facilities for shock-suction valves 1	
Facilities for LS A/B pilot relief valves and electric unloading LS A/B piloting 2	
Code numbers	
PDW71111000	PDW71111010
BSP	UN-UNF
A/B ports 1/2" Ls-LsA-LsB remote pressure connections 1/4"	A/B ports 7/8"-14UNF-2B Ls-LsA-LsB remote pressure connections 7/16"-20UNF-2B

Product

Hydraulic diagram

Description

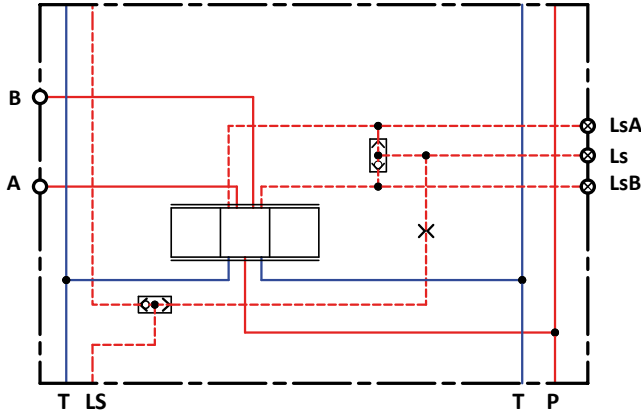
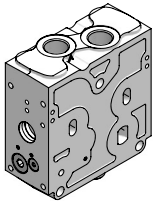

No facilities for shock-suction valves	
Code numbers	
PDW70000000	PDW70000010
BSP	UN-UNF
A/B ports 1/2" Ls-LsA-LsB piloting connections 1/4"	A/B ports 7/8" - 14UNF - 2B Ls-LsA-LsB piloting connections 7/16" - 20UNF - 2B

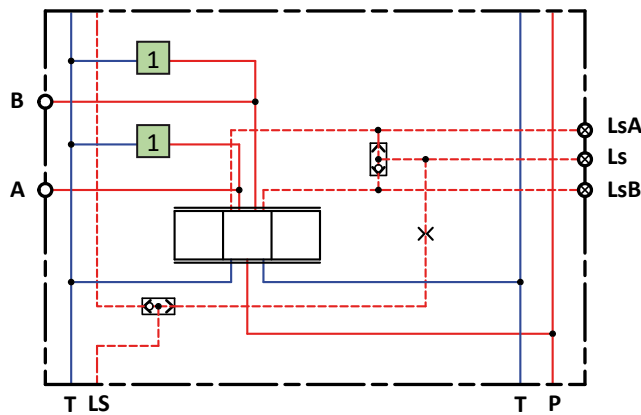
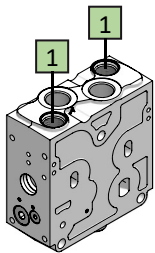

Facilities for shock-suction valves 1	
Code numbers	
PDW70010000	PDW70010010
BSP	UN-UNF
A/B ports 1/2" Ls-LsA-LsB piloting connections 1/4"	A/B ports 7/8" - 14UNF - 2B Ls-LsA-LsB piloting connections 7/16" - 20UNF - 2B

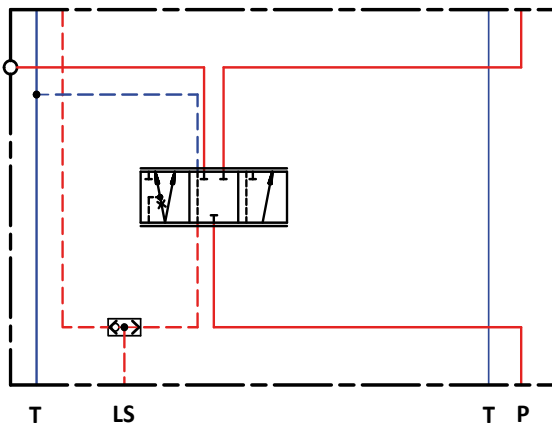
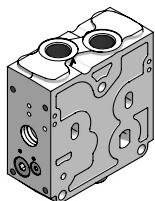

Functional safety cut-off system and diverter flow	
Code numbers	
PDW75000000	PDW75000010
BSP	UN-UNF
A/B ports 1/2" Ls-LsA-LsB piloting connections 1/4"	A/B ports 7/8" - 14UNF - 2B Ls-LsA-LsB piloting connections 7/16" - 20UNF - 2B

Product

Hydraulic diagram

Description

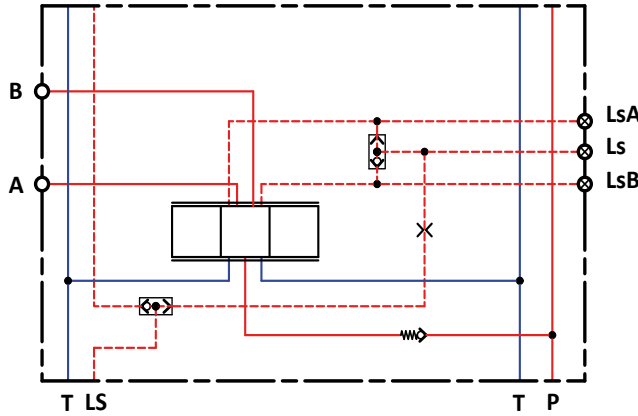
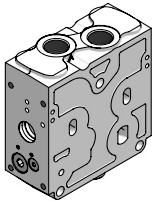

No facilities for shock-suction valves With load drop check valve on P channel	
Code numbers	
PDW7300000	PDW7300010
BSP	UN-UNF
A/B ports 1/2" Ls-LsA-LsB piloting connections 1/4"	A/B ports 7/8" - 14UNF - 2B Ls-LsA-LsB piloting connections 7/16" - 20UNF - 2B

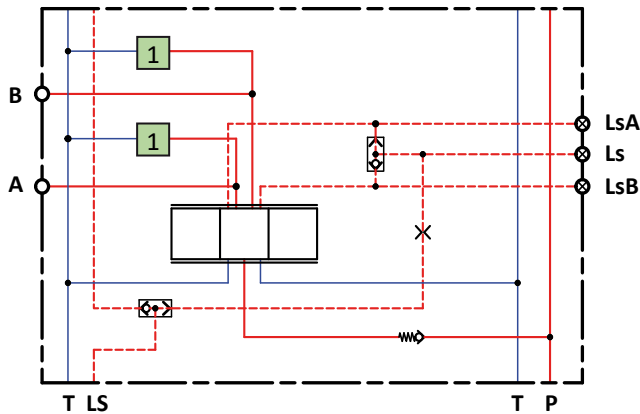
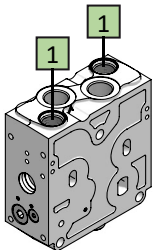

Facilities for shock-suction valve 1 With load drop check valve on P channel	
Code numbers	
PDW7301000	PDW7301010
BSP	UN-UNF
A/B ports 1/2" Ls-LsA-LsB piloting connections 1/4"	A/B ports 7/8" - 14UNF - 2B Ls-LsA-LsB piloting connections 7/16" - 20UNF - 2B

Product

Hydraulic diagram

Description

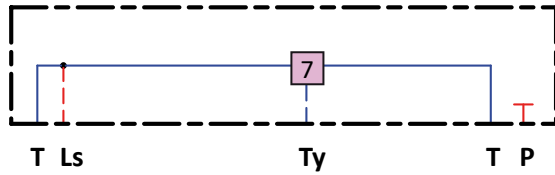
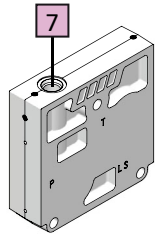

No ported, prearranged for external/internal drain **7**

Code numbers	
PDE07010002	PDE07010012
BSP	UN-UNF
Ty ports 1/4"	Ty ports 7/16"-20UNF-2B

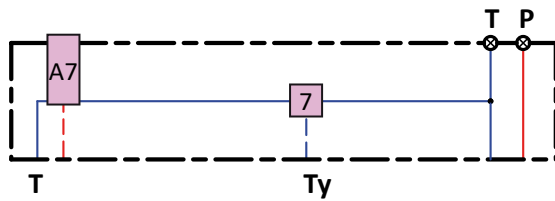
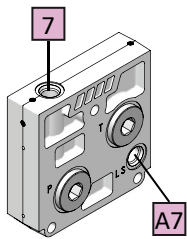

Ls port **A7** prearranged for external/internal drain **7**

Code numbers	
PDE07210002	PDE07210012
BSP	UN-UNF
P, T ports 3/4" Ls, Ty ports 1/4"	P, T ports 1 1/16"-12UN-2B Ls, Ty ports 7/16"-20UNF-2B

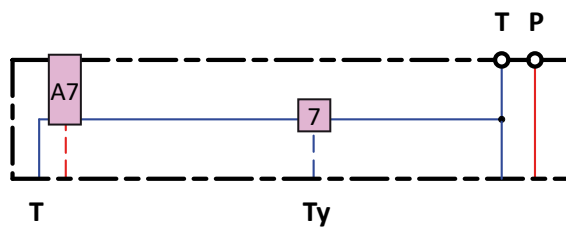
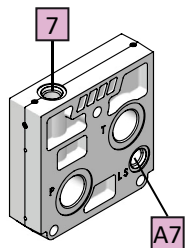

P-T-Ls ports **A7** prearranged for external/internal drain **7**

Code numbers	
PDE07110002	PDE07110012
BSP	UN-UNF
Connections thread see page____	Connections thread see page____

Product

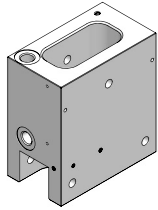

Hydraulic diagram

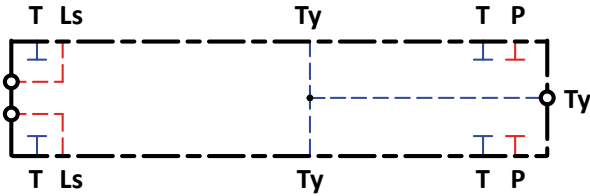

Description

MID end section	
Code numbers	
PDEM7010000	PDEM7010010
BSPP	UN-UNF
Ls, Ty ports 1/4"	Ls, Ty ports 7/16"-20UNF-2B

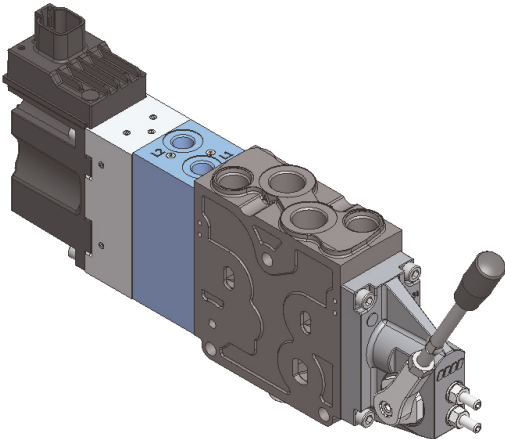

PDZ is a small HIC body that can be matched with any kind of PDV74 working section PDW, to get hydraulic and electro-hydraulic spool control

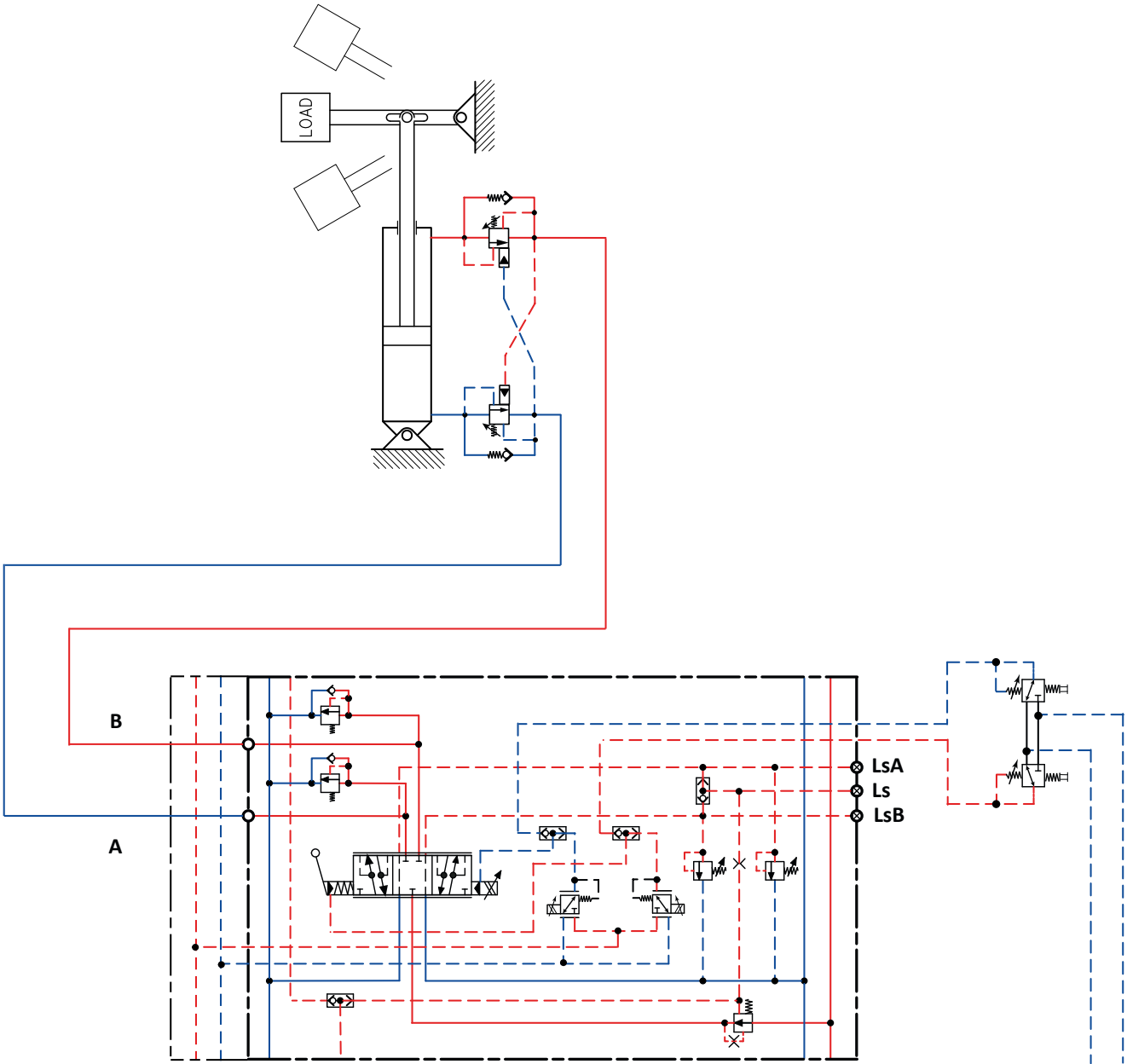

PDZ overall dimensions	For open loop spool control (Aluminium)	For closed loop spool control (Cast Iron)
	<p align="center">PDZ70000000 1/4" BSPP - 12 mm deep</p>	<p align="center">PDZ71000000 1/4" BSPP - 12 mm deep</p>
	<p align="center">PDZ70100000 [7/16 in-20 UNF-2B - 0,47 in deep]</p>	<p align="center">PDZ71100000 [7/16 in-20 UNF-2B - 0,47 in deep]</p>

Oil flow characteristics

With flow control spool, the oil flow depends on type of PDW module (with or without pressure compensator) and type of pump (fixed or variable displacement).

In the below chart, the ordinate numbers refer to spool size, and the ordinal numbers refer to the same spool size but fitted in a different position with related lost flow.

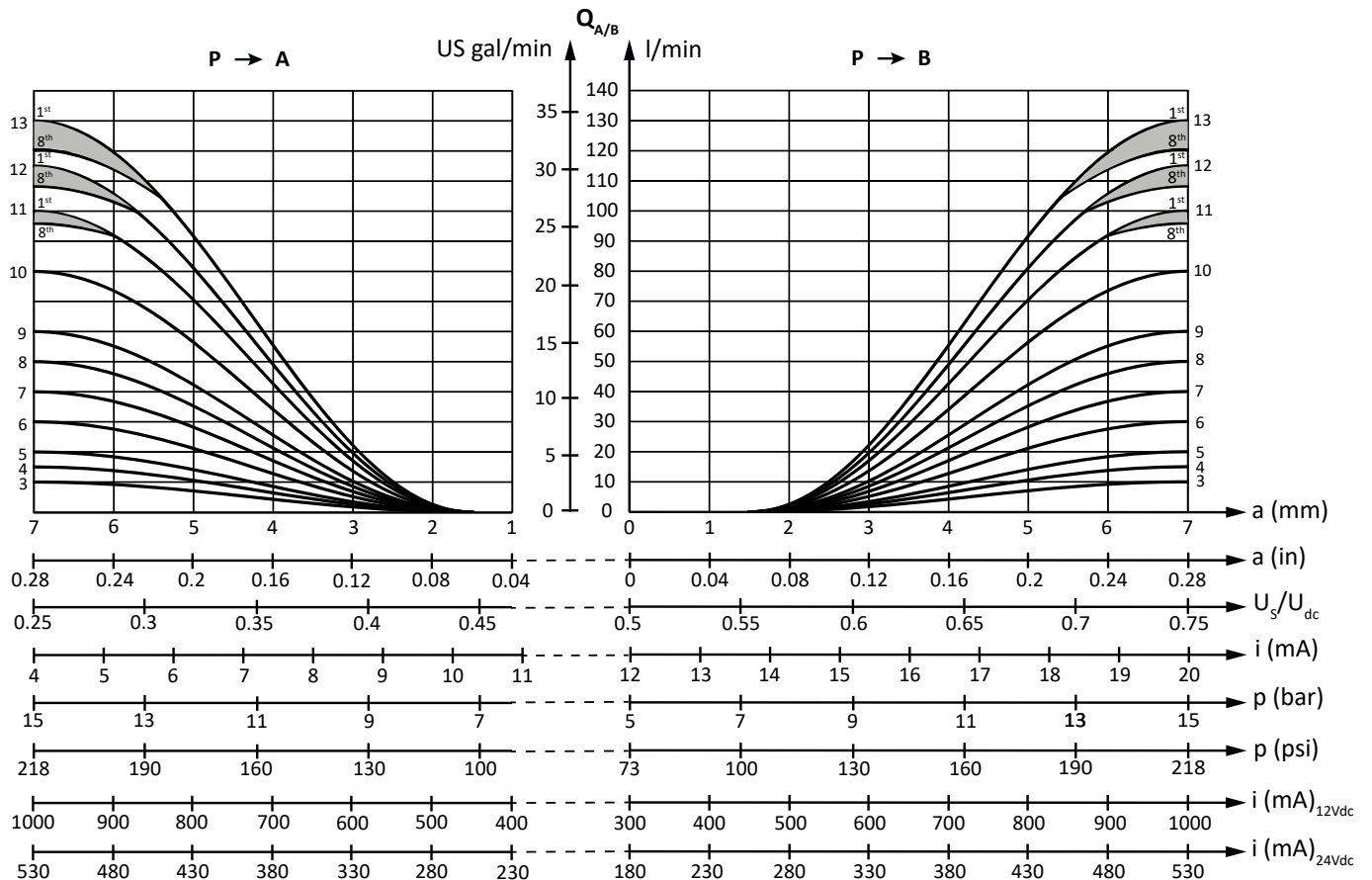
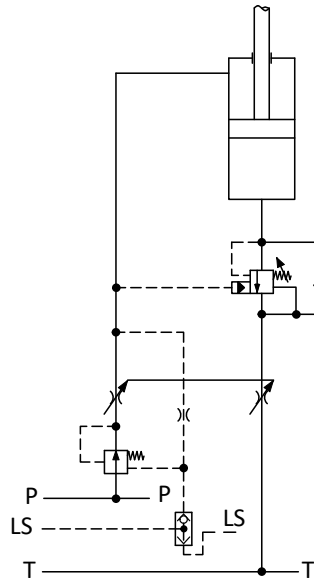

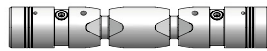
Double acting flow control spool

Size	Max oil flow pressure compensated l/min	Code numbers and symbol			
		4-way, 3-position - A, B closed	4-way, 3-position, A, B → T	4-way, 3-position, B → T; A closed	4-way, 3-position, A → T; B closed
1	5	PDS00210101	PDS00220102	PDS00280101	PDS00280102
2	7,5	PDS00210102	PDS00220103	PDS00280103	PDS00280104
3	10	PDS00210103	PDS00220104	PDS00280105	PDS00280106
4	15	PDS00210105	PDS00220106	PDS00280107	PDS00280108
5	20	PDS00210106	PDS00220107	PDS00280109	PDS00280110
5,5	25	PDS00210121	PDS00220122	PDS00280111	PDS00280112
6	30	PDS00210107	PDS00220108	PDS00280113	PDS00280114
7	40	PDS00210109	PDS00220110	PDS00280115	PDS00280116
8	50	PDS00210110	PDS00220111	PDS00280117	PDS00280118
9	60	PDS00210111	PDS00220112	PDS00280119	PDS00280120
10	80	PDS00210113	PDS00220114	PDS00280121	PDS00280122
11	100	PDS00210115	PDS00220116	PDS00280123	PDS00280124
12	115	PDS00210117	PDS00220118	PDS00280125	PDS00280126
13	130	PDS00210119	PDS00220120	PDS00280127	PDS00280128

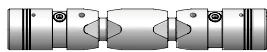
Double acting asymmetric flow control spool

Max oil flow pressure compensated l/min		Code numbers and symbol			
		4-way, 3-position - A, B closed	4-way, 3-position, A, B → T	4-way, 3-position, B → T; A closed	4-way, 3-position, A → T; B closed
A	B				
15	7,5	PDS00230101	PDS00230102	PDS00270103	PDS00270102
20	40	PDS00230117	PDS00230118	PDS00270119	PDS00270120
25	15	PDS00230123	PDS00230124	PDS00270125	PDS00270126
30	40	-	PDS00230116	PDS00270115	PDS00270116
30	50	PDS00230127	-	-	-
30	60	PDS00230131	-	-	-
40	20	PDS00230105	PDS00230104	PDS00270101	PDS00270104
40	30	PDS00230115	PDS00230130	PDS00270117	PDS00270118
40	60	PDS00230113	PDS00230114	PDS00270113	PDS00270114
40	110	PDS00230129	-	-	-
50	30	PDS00230121	PDS00230122	PDS00270123	PDS00270124
60	40	PDS00230125	PDS00230126	-	-
65	30	PDS00230107	PDS00230106	PDS00270105	PDS00270106
75	30	PDS00230103	PDS00230112	PDS00270111	PDS00270112
80	40	PDS00230119	PDS00230120	PDS00270121	PDS00270122
110	40	PDS00230109	PDS00230108	PDS00270107	PDS00270108
130	60	PDS00230111	PDS00230110	PDS00270109	PDS00270110

Single acting flow control spool

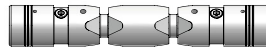

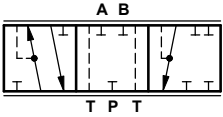
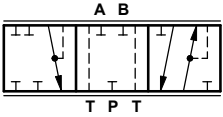
Size	Max oil flow pressure compensated l/min	Symbol and code numbers	
			
		3-way, 3-position P → A	3-way, 3-position P → B
1	7,5	PDS00750101	PDS00750102
2	15	PDS00750103	PDS00750104
3	20	PDS00750105	PDS00750106
4	30	PDS00750107	PDS00750108
5	40	PDS00750109	PDS00750110
6	50	PDS00750111	PDS00750112
7	60	PDS00750113	PDS00750114
8	80	PDS00750115	PDS00750116
9	100	PDS00750117	PDS00750118

Double acting flow control spool, floating position

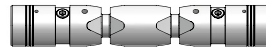

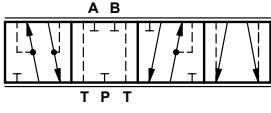
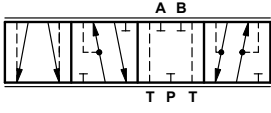
Size	Max oil flow pressure compensated l/min	Symbol and code numbers	
			
		3-way, 4-position floating position on A port	3-way, 4-position floating position on B port
1	10	PDS00730101	PDS00740101
2	15	PDS00730102	PDS00740102
3	25	PDS00730103	PDS00740103
4	40	PDS00730104	PDS00740104
5	50	PDS00730105	PDS00740105

Spool centered set, code numbers (needed for any kind of flow control spool)

Tightening torque		Tightening torque
6 ⁺¹ ₀ Nm		6 ⁺¹ ₀ Nm
53,1 ^{+8,85} ₀ lb*in		53,1 ^{+8,85} ₀ lb*in
Manual control	PDR00300101	
Hydraulic - Electrohydraulic	PDR00300102	

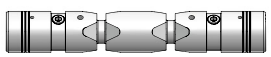
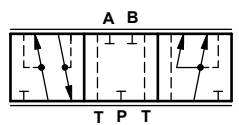
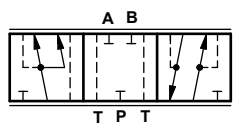
Double acting flow control, regenerative function			
			
Size	Max oil flow pressure compensated l/min	Symbol and code numbers	
			
		Regenerative circuit on A port	Regenerative circuit on B port
1	7,5		
2	15	PDS00610103	PDS00610104
3	20	PDS00610105	PDS00610106
4	30	PDS00610107	PDS00610108
5	40	PDS00610109	PDS00610110
6	50	PDS00610111	PDS00610112
7	60		
8	80	PDS00610115	PDS00610116
9	100		
10	130		

Spool centered set, code numbers (needed for any kind of flow control spool)		
Tightening torque		Tightening torque
6^{+1}_0 Nm		6^{+1}_0 Nm
$53,1^{+8,85}_0$ lb*in		$53,1^{+8,85}_0$ lb*in
Manual control	PDR00300101	
Hydraulic - Electrohydraulic	PDR00300102	

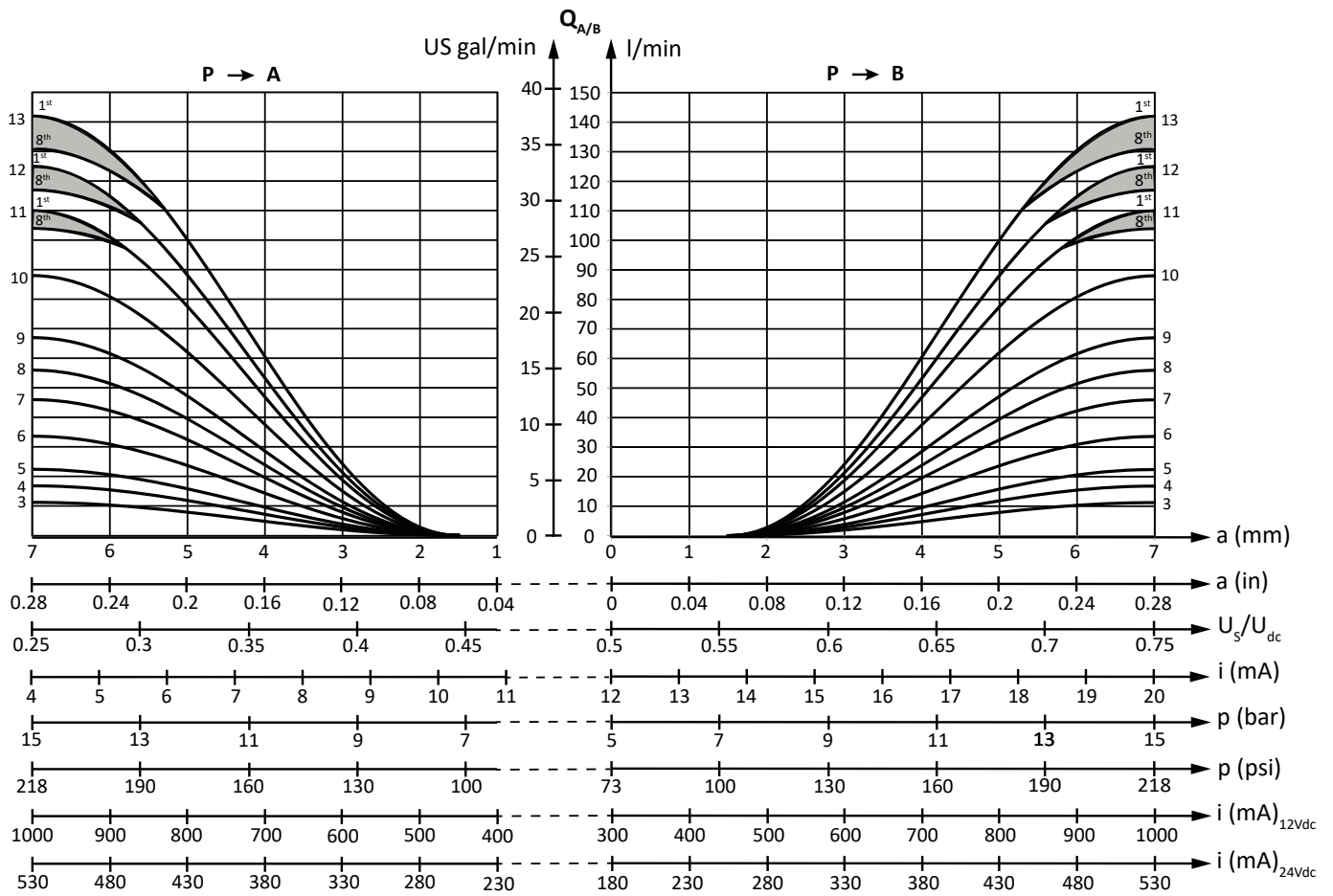

Oil flow characteristics PDW without pressure compensator, and pump differential pressure setting = 16 bar

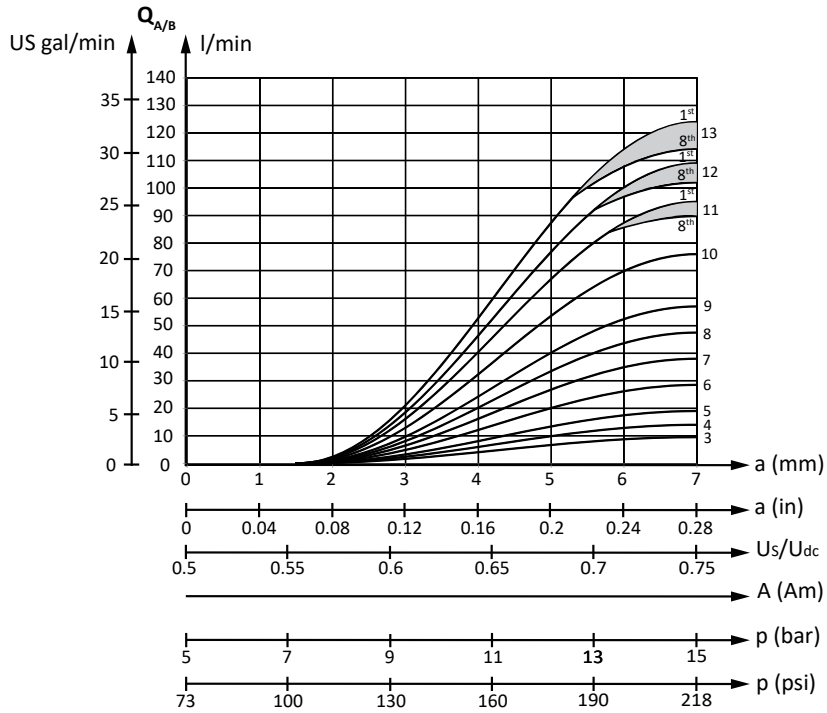

Oil flow characteristics PDW without pressure compensator, and pump differential pressure setting = 25 bar

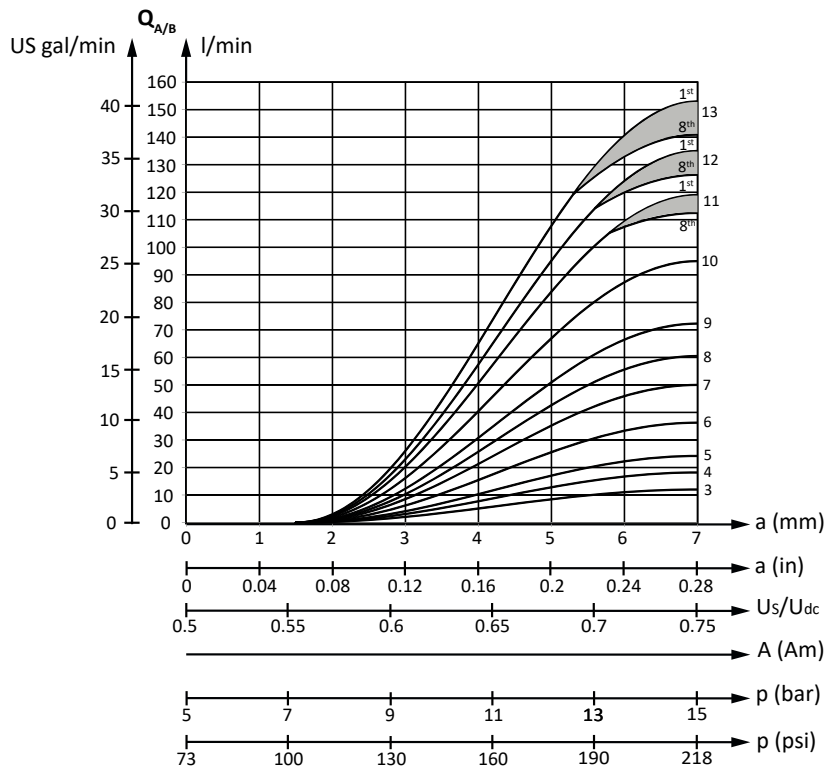

Oil flow PDW pressure compensated with LS A/B pilot relief valves

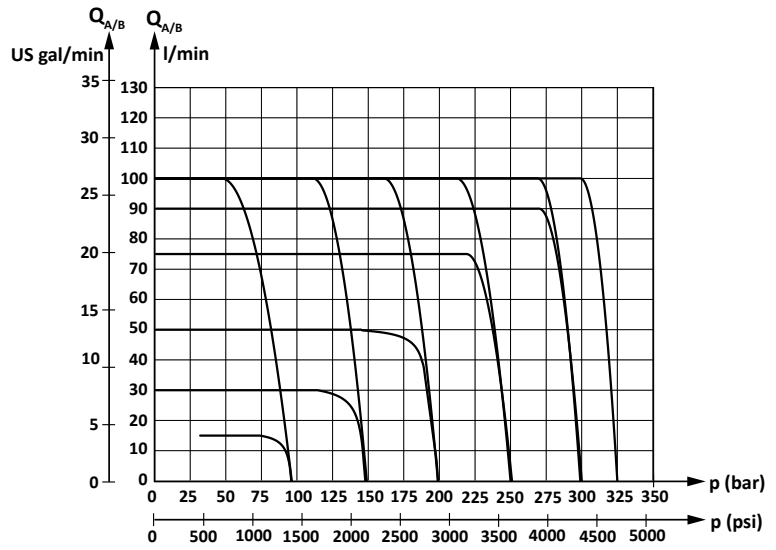

Load independent oil flow pressure compensated PDW

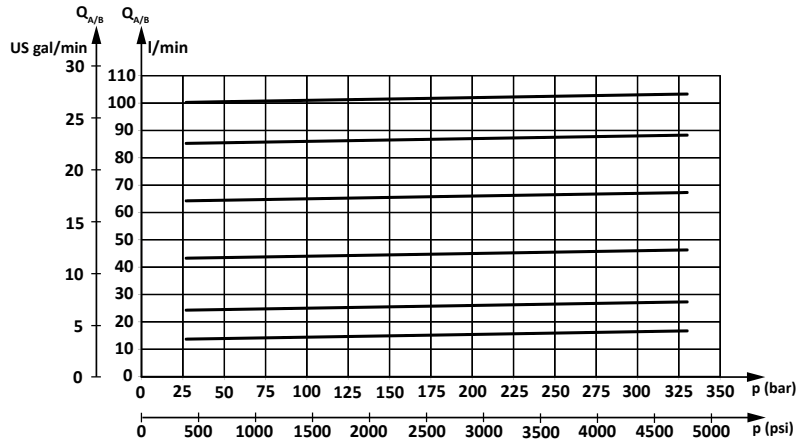

PDW pressure drop at max main spool travel

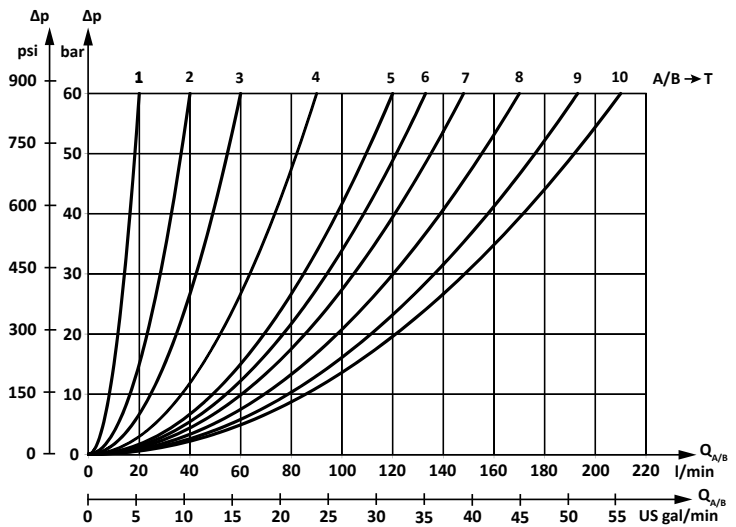

By using proportional directional valves along with overcenter valves, instability problems may occur in the form of pressure surging.

To solve these problems, spools with different circuit named "Pressure Control" have been developed.

The main purpose of these spools, is to hold in position the 2-way pressure compensator, preventing it from going into unstable condition, and in turn, to keep the overcenter's pilot pressure value as stable as possible.

Pressure control spools, must always be used with pressure compensated working sections equipped with pilot LS A/B relief valves.

Pressure control spool, normally give a higher degree of stability to whole hydraulic system, however, we advise to look after their use, because:

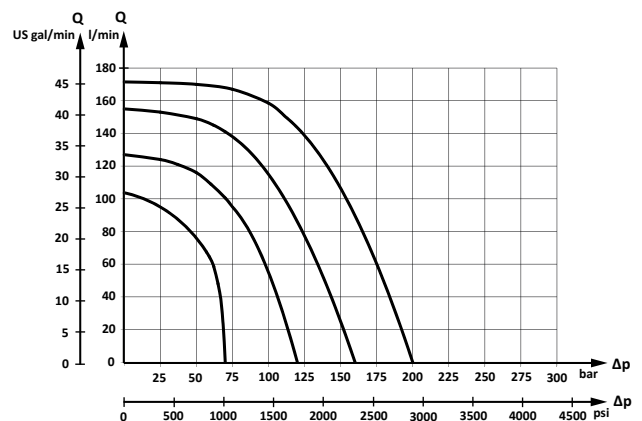
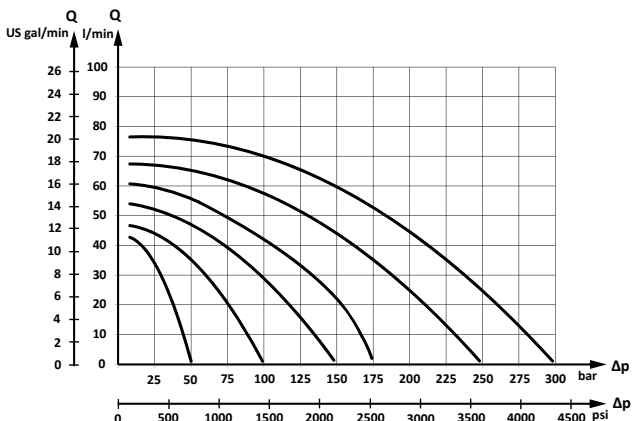
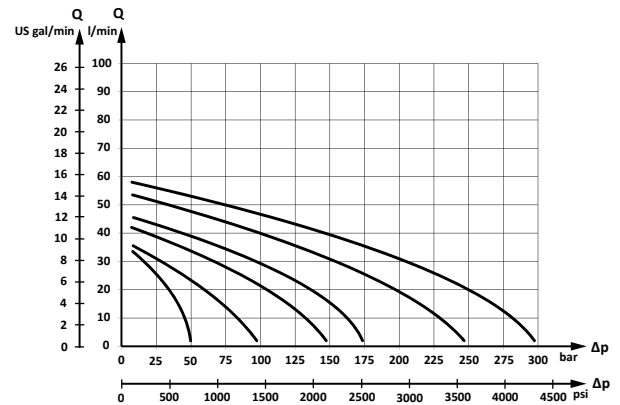
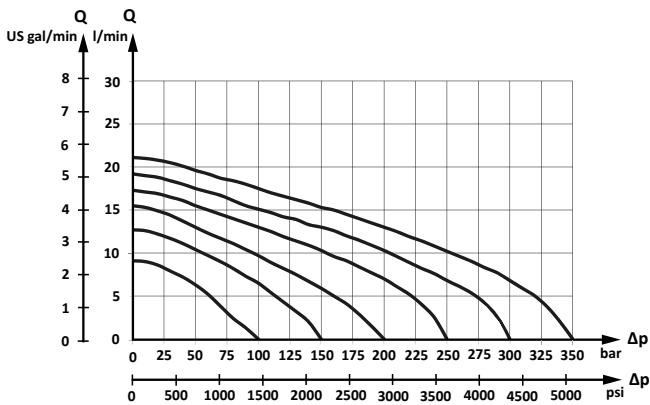
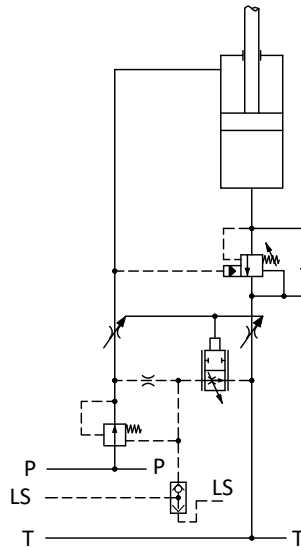

- The valve may lose a bit of pressure compensation, becoming load dependent.
- The pump pressure may be considerably higher than that necessary to move the load.





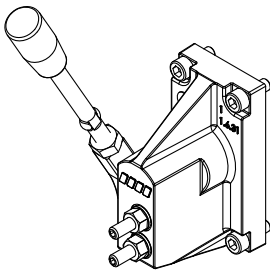
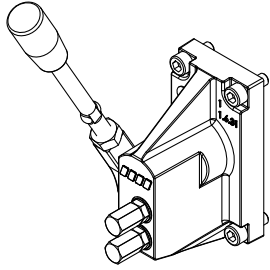
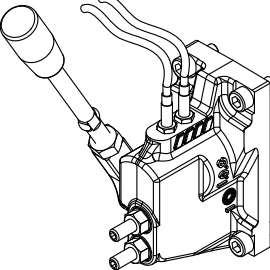
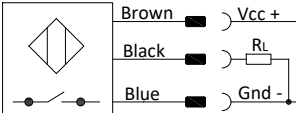
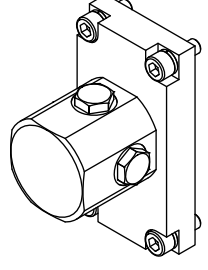
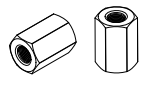

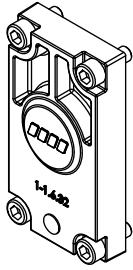
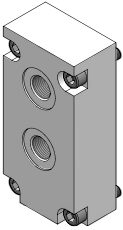
Pressure control spool						
Symbol and code numbers (PC = Pressure control - FC = Flow control)						
Size						
	4-way, 3-position, A, B closed	4-way, 3-position, A, B throttled open to T	4-way, 3-position, A, B closed	4-way, 3-position, A, B closed	4-way, 3-position, A throttled open to T, B closed	4-way, 3-position, A closed, B throttled open to T
1	PDS00710113 PC→A + B	PDS00720114 PC→A + B	PDS00760113 PC→A FC→B, Q=-l/min	PDS00770114 PC→B FC→A, Q=-l/min	PDS00780113 PC→A FC→B, Q=-l/min	PDS00790114 PC→B FC→A, Q=-l/min
	-	-	PDS00760121 PC→A FC→B, Q=-l/min	-	-	-
2	PDS00710115 PC→A + B	PDS00720116 PC→A + B	PDS00760115 PC→A FC→B, Q=-l/min	PDS00770116 PC→B FC→A, Q=-l/min	PDS00780115 PC→A FC→B, Q=-l/min	PDS00790116 PC→B FC→A, Q=-l/min
3	PDS00710117 PC→A + B	PDS00720118 PC→A + B	PDS00760117 PC→A FC→B, Q=-l/min	PDS00770118 PC→B FC→A, Q=-l/min	PDS00780117 PC→A FC→B, Q=-l/min	PDS00790118 PC→B FC→A, Q=-l/min
3,5	PDS00710111 PC→A + B	PDS00720112 PC→A + B	PDS00760111 PC→A FC→B, Q=-l/min	PDS00770112 PC→B FC→A, Q=-l/min	PDS00780111 PC→A FC→B, Q=-l/min	PDS00790112 PC→B FC→A, Q=-l/min
4	PDS00710119 PC→A + B	PDS00720120 PC→A + B	PDS00760119 PC→A FC→B, Q=-l/min	PDS00770120 PC→B FC→A, Q=-l/min	PDS00780119 PC→A FC→B, Q=-l/min	PDS00790120 PC→B FC→A, Q=-l/min

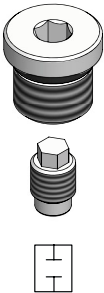
Spool centered set, code numbers (needed for any kind of flow control spool)		
Tightening torque		Tightening torque
6 ⁺¹ ₀ Nm		6 ⁺¹ ₀ Nm
53,1 ^{+8,85} ₀ lb*in		53,1 ^{+8,85} ₀ lb*in
Manual control	PDR00300101	
Hydraulic - Electrohydraulic	PDR00300102	

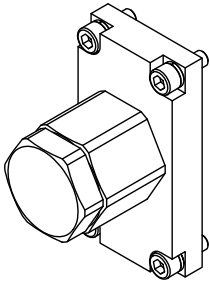
Product	Description	Aluminium	Cast iron
	Mechanical actuation	With lever	
		PDM10101000	PDM11101000
		Without lever	
		PDM101000000	PDM111000000
	Mechanical actuation, with flow adjustment nuts protection	With lever	
		PDM10201000	PDM11201000
		Without lever	
		PDM10200000	PDM11200000
	Mechanical actuation with directional sensors for electrical monitoring of spool valve movement  Vcc 10 V ... 30 V I < 200 mA	With lever	
		Normally closed:	PDM11111000
		Normally open:	PDM11121000
	Friction detent (for mechanical actuation only)	Cast iron only	
		PDF10000001	
	Flow adjustment protection nuts for PDM mechanical control		

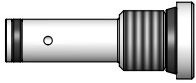
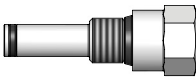
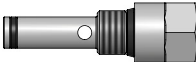
Product	Description	Aluminium	Cast iron
PDC 	Rear cover for mechanical actuation	PDC00000000	PDC10000000
PDH 	Hydraulic actuation	A/B pilot port 1/4 BSPP deep: 12 mm (0,47 in) PDH70000000	A/B pilot port 1/4 BSPP deep: 12 mm (0,47 in) PDH71000000
		A/B pilot port 7/16-20UNF-2B deep: 12 mm (0,47 in) PDH70000100	A/B pilot port 7/16-20UNF-2B deep: 12 mm (0,47 in) PDH71000100
	Pilot LS _{A/B} relief valve	50 ÷ 80 bar	PLS0A100000
		81 ÷ 380 bar	PLS0A400000
	Plug for pilot LS _{A/B} relief valve cavity	PLS0P000000	

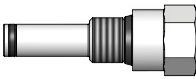
Product	Description	Cast iron only
<p style="text-align: center;">PDD</p> 	<p style="text-align: center;">Mechanical spool lock device, manual release</p>	<p>P→A - lock P→B - free PDD70100000</p>
		<p>P→A - free P→B - lock PDD70010000</p>
		<p>P→A - lock P→B - lock PDD70110000</p>
		<p>P→A - float P→B - free PDD70200000</p>
		<p>P→A - free P→B - float PDD70020000</p>

Product	Description	Code numbers	
<p>PIZ</p> 	<p>For PDI with internal pilot oil supply</p>	<p>PIZ10000000</p>	
<p>PIY</p> 	<p>For PDI with external pilot oil supply</p>	<p>A/B pilot port 1/4 BSPP deep: 12 mm (0,47 in) PIY10000000</p>	<p>A/B pilot port 7/16-20UNF-2B deep: 12 mm (0,47 in) PIY10000010</p>
	<p>For PDE with external drain line electrical actuation</p>	<p>A/B pilot port 1/4 BSPP deep: 12 mm (0,47 in) PED10000000</p>	<p>A/B pilot port 7/16-20UNF-2B deep: 12 mm (0,47 in) PED10000010</p>
	<p>For PDE with internal drain line electrical actuation</p>	<p>PEI10000000</p>	
	<p>For PDE with LS carry-over</p>	<p>A/B pilot port 1/4 BSPP deep: 12 mm (0,47 in) PED20000000</p>	<p>A/B pilot port 7/16-20UNF-2B deep: 12 mm (0,47 in) PED20000010</p>
	<p>For PDE prearranged LS carry-over</p>	<p>PEI10000000</p>	

PWS, PWA and **PWB** are shock suction valves design to absorb shock effects only, and they should never be used as a pressure relief valves.
PWS, PWA and **PWB** are set at an oil flow of 10 l/min. If the hydraulic actuator requires a pressure relief valve function, a PDW module with built-in LS_{A/B} pilot pressure limit valves should be used

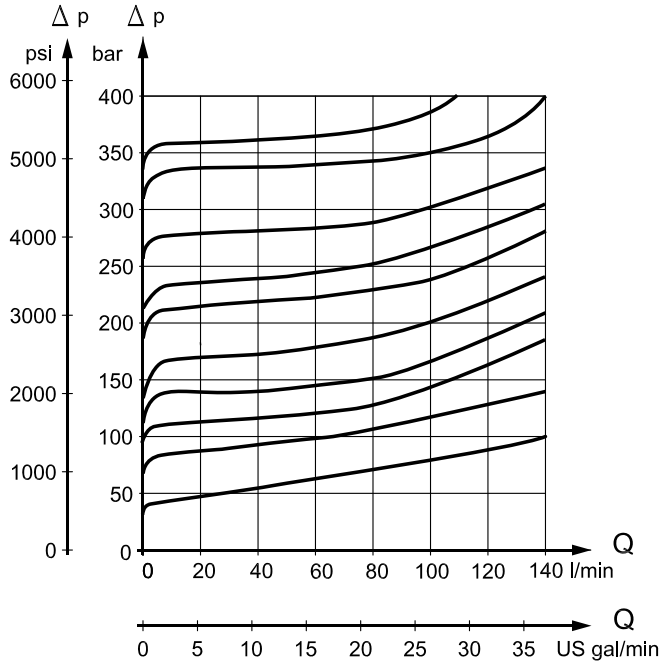

PWR suction valve

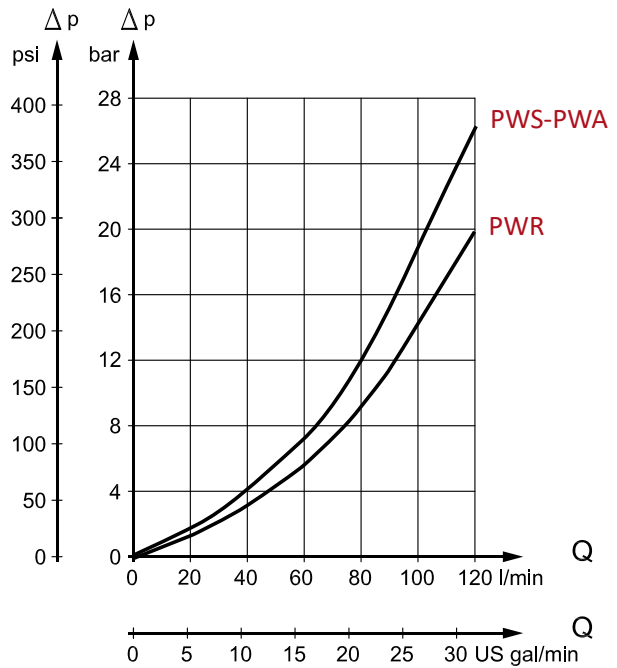

PWS shock and suction valve for A/B port. Not adjustable

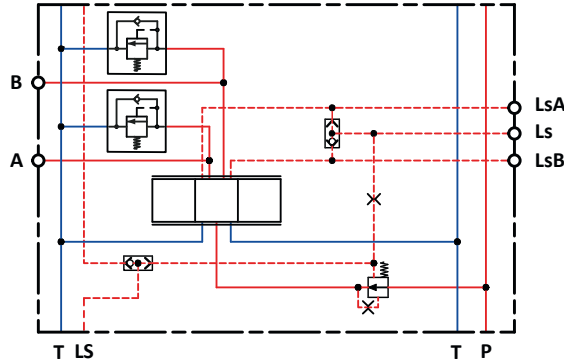
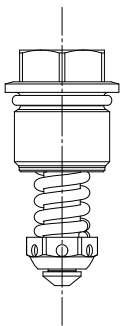

Setting Pressure(bar)	Code numbers
50	PWS7M180050
70	PWS7M180070
90	PWS7M180090
110	PWS7M180110
130	PWS7M180130
150	PWS7M180150
180	PWS7M180180
200	PWS7M180200
230	PWS7M180230
260	PWS7M180260
290	PWS7M180290
320	PWS7M180320
350	PWS7M180350
380	PWS7M180380

PWA shock and suction valve for A/B port. Adjustable

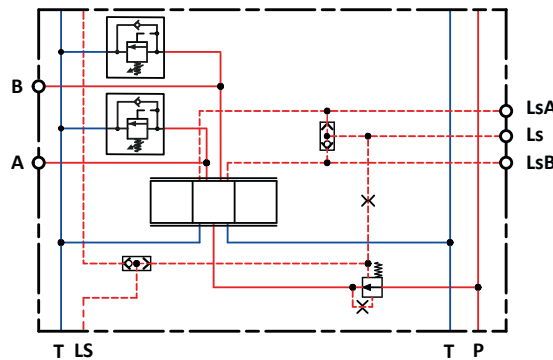
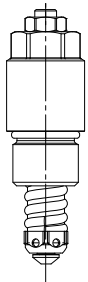

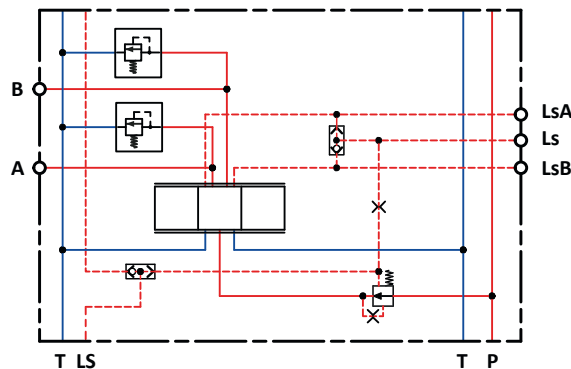
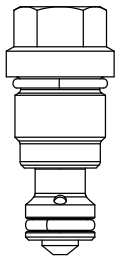

Range setting (bar)	Code numbers
20 ÷ 70	PWA7M180N00
71 ÷ 130	PWA7M180B00
131 ÷ 210	PWA7M180G00
211 ÷ 280	PWA7M180V00
281 ÷ 350	PWA7M180W00
351 ÷ 420	PWA7M180R00

PWB shock valve for A/B port. Not adjustable

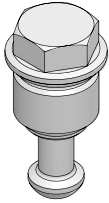
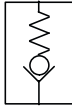
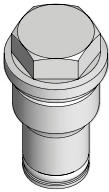

Setting pressure(bar)	Code numbers
50	PWB7M180050
70	PWB7M180070
90	PWB7M180090
110	PWB7M180110
130	PWB7M180130
150	PWB7M180150
180	PWB7M180180
200	PWB7M180200
230	PWB7M180230
260	PWB7M180260
290	PWB7M180290
320	PWB7M180320
350	PWB7M180350
380	PWB7M180380

PWR suction valve for A/B port		
Product	Hydraulic diagram	Code numbers
		PWR7M180000
Plug for PWS - PWA - PWB and PWR cavity		
Product	Hydraulic diagram	Code numbers
		PWP7M180000

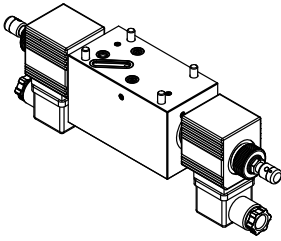

When PDL is energized, the piloting signal is lead to tank and in turn the work port oil flow will be cutted off.

PDL modules is always to be matched with PDW pressure compensated.

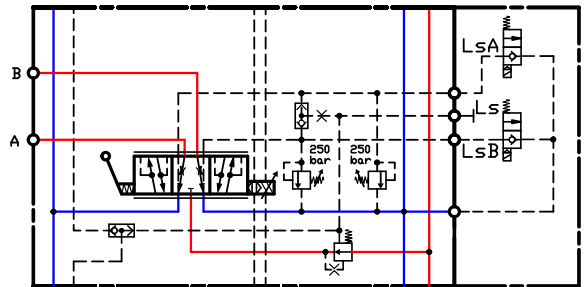
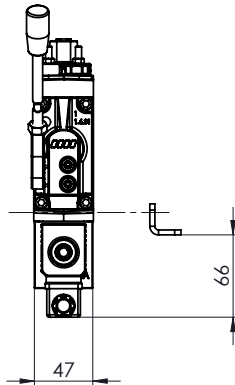
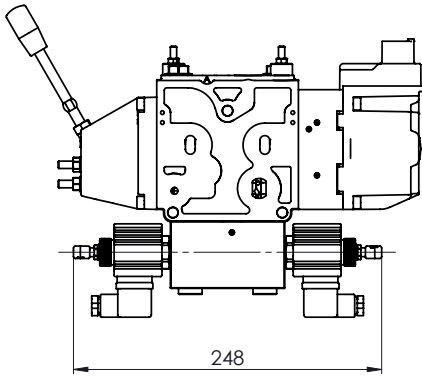

PDL code numbers

Hydraulic diagram	Connector type	12V dc	24V dc
Active on L_sA 	Deutsch Parallel	PDL12C11200	PDL12C31200
	Deutsch Perpendicular	PDL12C12200	PDL12C32200
	DIN	PDL12C13200	PDL12C33200
	JPT	PDL12C14200	PDL12C34200
Active on L_sB 	Deutsch Parallel	PDL13C11200	PDL13C31200
	Deutsch Perpendicular	PDL13C12200	PDL13C32200
	DIN	PDL13C13200	PDL13C33200
	JPT	PDL13C14200	PDL13C34200
Active on L_sA and L_sB 	Deutsch Parallel	PDL11C11200	PDL11C31200
	Deutsch Perpendicular	PDL11C12200	PDL11C32200
	DIN	PDL11C13200	PDL11C33200
	JPT	PDL11C14200	PDL11C34200
Active on L_s 	Deutsch Parallel	PDL14C11200	PDL14C31200
	Deutsch Perpendicular	PDL14C12200	PDL14C32200
	DIN	PDL14C13200	PDL14C33200
	JPT	PDL14C14200	PDL14C34200

PDL code numbers			
Hydraulic diagram	Connector type	12V dc	24V dc
<p style="text-align: center;"><i>Active on LsA</i></p>	Deutsch Parallel	PDL32C11200	PDL32C31200
	Deutsch Perpendicular	PDL32C12200	PDL32C32200
	DIN	PDL32C13200	PDL32C33200
	JPT	PDL32C14200	PDL32C34200
<p style="text-align: center;"><i>Active on LsB</i></p>	Deutsch Parallel	PDL33C11200	PDL33C31200
	Deutsch Perpendicular	PDL33C12200	PDL33C32200
	DIN	PDL33C13200	PDL33C33200
	JPT	PDL33C14200	PDL33C34200
<p style="text-align: center;"><i>Active on LsA and LsB</i></p>	Deutsch Parallel	PDL35C11200	PDL35C31200
	Deutsch Perpendicular	PDL35C12200	PDL35C32200
	DIN	PDL35C13200	PDL35C33200
	JPT	PDL35C14200	PDL35C34200
<p style="text-align: center;"><i>Active on Ls</i></p>	Deutsch Parallel	PDL34C11200	PDL34C31200
	Deutsch Perpendicular	PDL34C12200	PDL34C32200
	DIN	PDL34C13200	PDL34C33200
	JPT	PDL34C14200	PDL34C34200

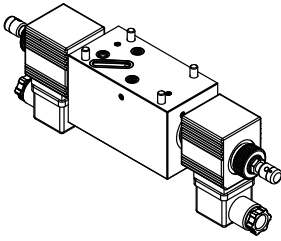

When PDL is deenergized, the piloting signal is lead to tank and in turn the work port oil flow will be cutted off.
 PDL modules is always to be matched with PDW pressure compesated.

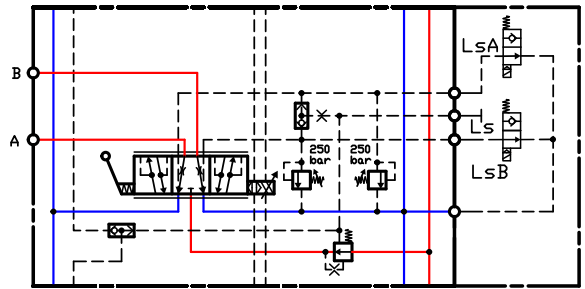
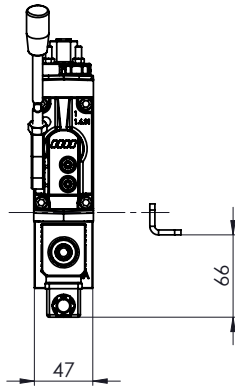
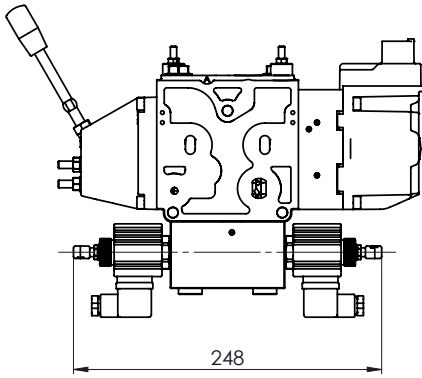

PDL code numbers			
Hydraulic diagram	Connector type	12V dc	24V dc
<i>Active on L_sA</i> 	Deutsch Parallel	PDL32A11100	PDL32A31100
	Deutsch Perpendicular	PDL32A12100	PDL32A32100
	DIN	PDL32A13100	PDL32A33100
	JPT	PDL32A14100	PDL32A34100
<i>Active on L_sB</i> 	Deutsch Parallel	PDL33A11100	PDL33A31100
	Deutsch Perpendicular	PDL33A12100	PDL33A32100
	DIN	PDL33A13100	PDL33A33100
	JPT	PDL33A14100	PDL33A34100
<i>Active on L_sA and L_sB</i> 	Deutsch Parallel	PDL35A11100	PDL35A31100
	Deutsch Perpendicular	PDL35A12100	PDL35A32100
	DIN	PDL35A13100	PDL35A33100
	JPT	PDL35A14100	PDL35A34100
<i>Active on L_s</i> 	Deutsch Parallel	PDL34A11100	PDL34A31100
	Deutsch Perpendicular	PDL34A12100	PDL34A32100
	DIN	PDL34A13100	PDL34A33100
	JPT	PDL34A14100	PDL34A34100

PDL code numbers

Hydraulic diagram	Connector type	12V dc	24V dc
<p><i>Active on LsA</i></p>	Deutsch Parallel	PDL12A11100	PDL12A31100
	Deutsch Perpendicular	PDL12A12100	PDL12A32100
	DIN	PDL12A13100	PDL12A33100
	JPT	PDL12A14100	PDL12A34100
<p><i>Active on LsB</i></p>	Deutsch Parallel	PDL13A11100	PDL13A31100
	Deutsch Perpendicular	PDL13A12100	PDL13A32100
	DIN	PDL13A13100	PDL13A33100
	JPT	PDL13A14100	PDL13A34100
<p><i>Active on LsA and LsB</i></p>	Deutsch Parallel	PDL11A11100	PDL11A31100
	Deutsch Perpendicular	PDL11A12100	PDL11A32100
	DIN	PDL11A13100	PDL11A33100
	JPT	PDL11A14100	PDL11A34100
<p><i>Active on Ls</i></p>	Deutsch Parallel	PDL14A11100	PDL14A31100
	Deutsch Perpendicular	PDL14A12100	PDL14A32100
	DIN	PDL14A13100	PDL14A33100
	JPT	PDL14A14100	PDL14A34100

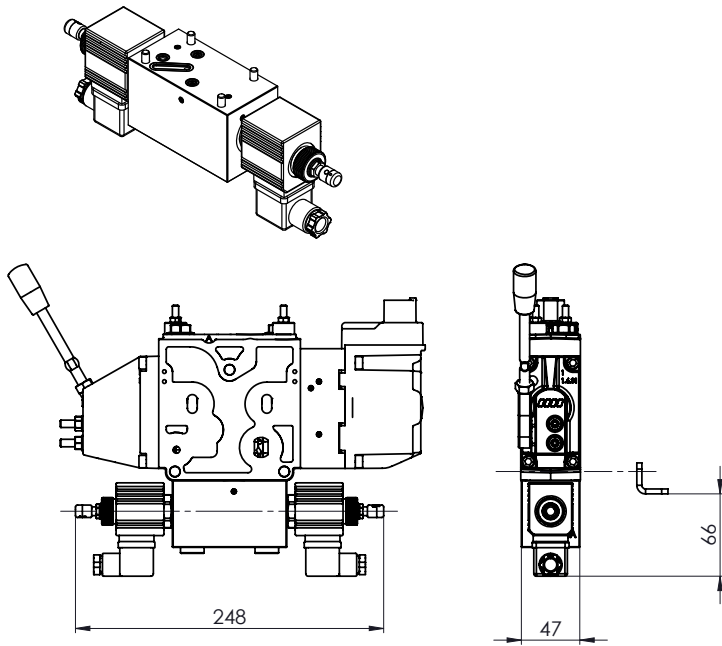

PDLD is an electro-hydraulic device that allows the A/B port working pressure to be remotely and proportionally operated according to a current signal (mA). When the working pressure exceeds the setting pressure value, the A/B port oil flow will be cutted off.
 When PDLD is not energized, PDV is almost pressureless, as well as the A-B oil flow is cutted off.

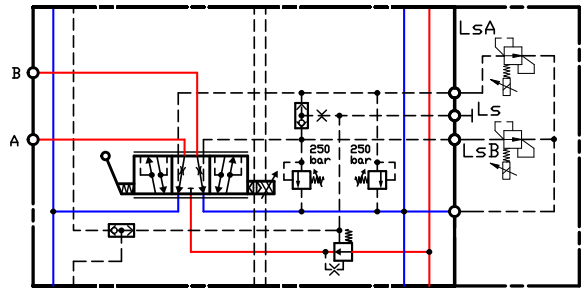

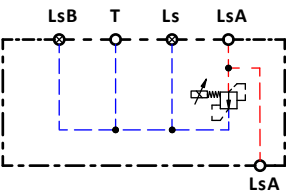
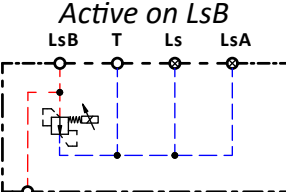
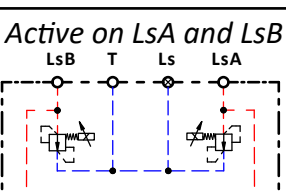
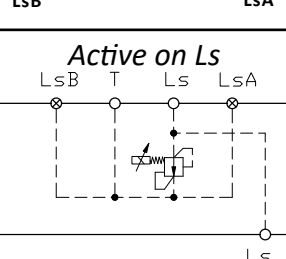
PDLD code numbers			
Hydraulic diagram	Connector type	12V dc	24V dc
<p><i>Active on LsA</i></p> 	Deutsch Parallel	PDL12D11000	PDL12D31000
<p><i>Active on LsB</i></p> 	Deutsch Parallel	PDL13D11000	PDL13D31000
<p><i>Active on LsA and LsB</i></p> 	Deutsch Parallel	PDL11D11000	PDL11D31000
<p><i>Active on Ls</i></p> 	Deutsch Parallel	PDL14D11000	PDL14D31000

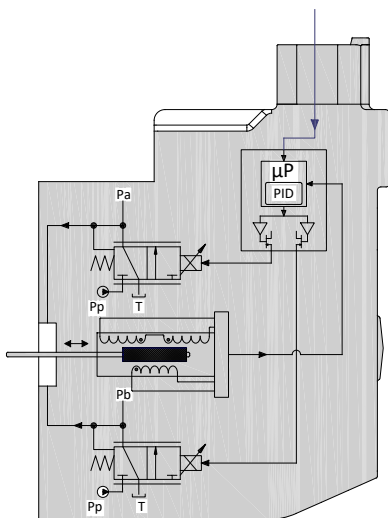
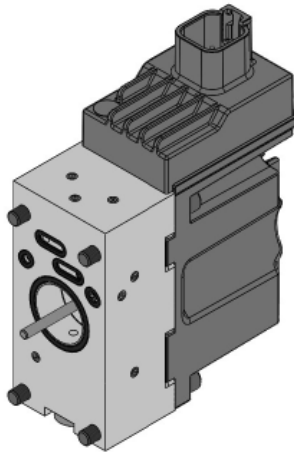

PEAC111 is a proportional high performance PDV spool actuation with integrated electronics and inductive transducer (LVDT) that operates safely and precisely the main spool movement according to an electrical signal coming from a remote control.

The input signal by means of the PCB and the two proportional pressure reducing valves, determines the level of the pilot pressure which moves the main spool.

The spool position is detected in the LVDT transducer which generates an electric feed-back signal registered by the electronics. The variation between the input signal and the feed-back signal, actuates the solenoid valves accordingly, so that, the hydraulic pilot pressure will drive the main spool in the right position.

All PEAC111 modules comes with integrated fault monitoring system, available in two version:

- Active version
- Passive version

Active fault monitoring

When an error state is detected, the two proportional solenoid valves will be automatically deactivated, a red lamp will light-up and drive the spool in neutral position (if it's not seized up). The system will only react to failures of more than 500 ms (in other words there is delay of half a second before anything happens). An alarm signal is sent out through the connector, and minus is opened.

This error state is memorized, and continues until the system is being reset by switching off the supply voltage.

Shortly, when the active fault monitoring system is connected and an error state is detected, the system ensures a fast and operator free reaction, that will put the complete hydraulic circuit into venting conditions, thus preventing uncontrollable machine movements.

Passive fault monitoring

When an error state is detected, the two proportional solenoid valves will not be deactivated, a red lamp will light-up, but still control the main spool.

When a fault condition occurs, after a delay of 250 ms an alarm signal is sent out through a devoted pin

This state is not memorized, and when the faulty state disappears, the alarm signal will turn to passive again.

In order to prevent the electronic from going into an undefined state, any time the system is being triggered or reset, a general check of power supply and the internal clock frequency is made.

The use of PEAC111 module both passive or active version, allows the machines hydraulic system to be made with different level of safety degree that for the choice of which it is essential to know the exactly required functions.

When the PEAC111 module active version is connected with the pump unloading system, the level of safety degree protection for the complete hydraulic system becomes very high, operator free, and helps OEM to meet the PL (Performance Level) required to be comply with the safety demands of Machinery Directive 2006/42/EC.

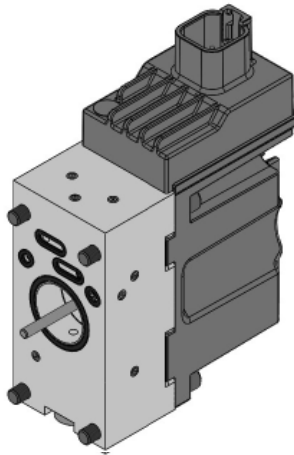
PEAC111 is defined by:

- Inductive transducer with resolution < 12 µm
- Integrated diagnosis and error memory
- Fault monitoring transistor output for signal source
- Higher spool control accuracy
- EMC performance according to Directive 2014/30/UE
- Low hysteresis
- Quicker reaction time
- Spool direction movement output
- Integrated PWM/Pulse Width Modulation
- Low electrical power

PEAC111 Technical data		
Rated supply voltage		10 ÷ 30 Vdc
Max ripple		5%
Signal control		0,5 Udc
Range control signal		0,25 Udc to 0,75 Udc
Neutral spool position		0,5 Udc
Max threshold signal, A port		1 V
Max threshold signal, B port		1 V
Max current signal @ rated voltage		48 mA
Input capacitor		100 nF
Signal control impedance		25 kΩ
Power consumption		8,7 W
Heat insulation		Class H (180°C)
Duty cycle		ED 100%
Max current consumption		650 mA
Current consumption in neutral position		80 mA
Coil impedance @ 20°C		8,9 Ω
Dither frequency		50-200 Hz
Recommended frequency		100 Hz
Enclosure degree	(Electrical wiring excepted)	IP 66 - IP 67 - IP 69K
Weight cast iron body		1,8 kg
Weight aluminium body		1,3 kg
Bootloader function, debugging parameters and set-up function available only with Deutsch connector DT06-6S		
Fault monitoring system	Max current on safety output (pin 5)	50 mA
	Reaction time a fault	500 ms
Max current output signal for spool direction movement		50 mA
Reaction time (constant voltage)	From neutral position to max spool travel	110 - 140 ms
	From max spool travel to neutral	70 - 90 ms
Reaction time (neutral switch)	From neutral position to max spool travel	130 - 170 ms
	From max spool travel to neutral	70 - 90 ms

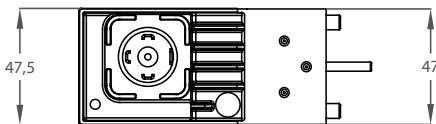
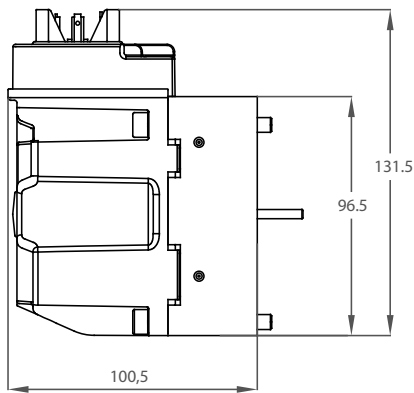
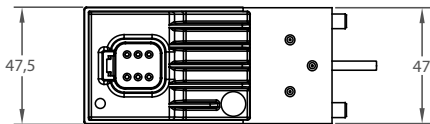
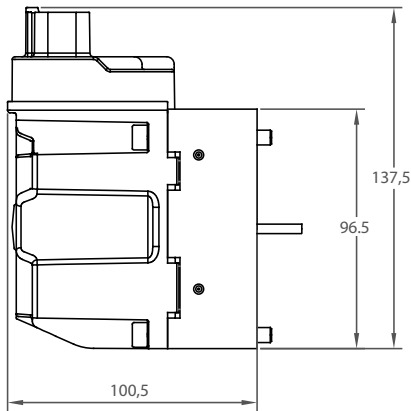

Deutsch connector DT06-6S Enclosure degree IP 69K PIN-assignment			
	1	Power supply	
	2	Input signal control	
	3	CAN-high	A port-spool movement signal
	4	CAN-low	B port-spool movement signal
	5	Fault monitoring signal	
	6	Ground	

Hirschmann connector DIN 43650 Enclosure degree IP 65 PIN-assignment			
	1	Power supply	
	2	Input signal control	
	3	Fault monitoring signal	
	4	Ground	

Connector version	Code numbers			
	Active version		Passive version	
	Cast-iron body	Aluminium body	Cast-iron body	Aluminium body
Deutsch DT06-6S	PEAC0121000	PEAC1121000	PEAC0111000	PEAC1111000
DIN 43650	PEAC0121200	PEAC1121200	PEAC0111200	PEAC1111200

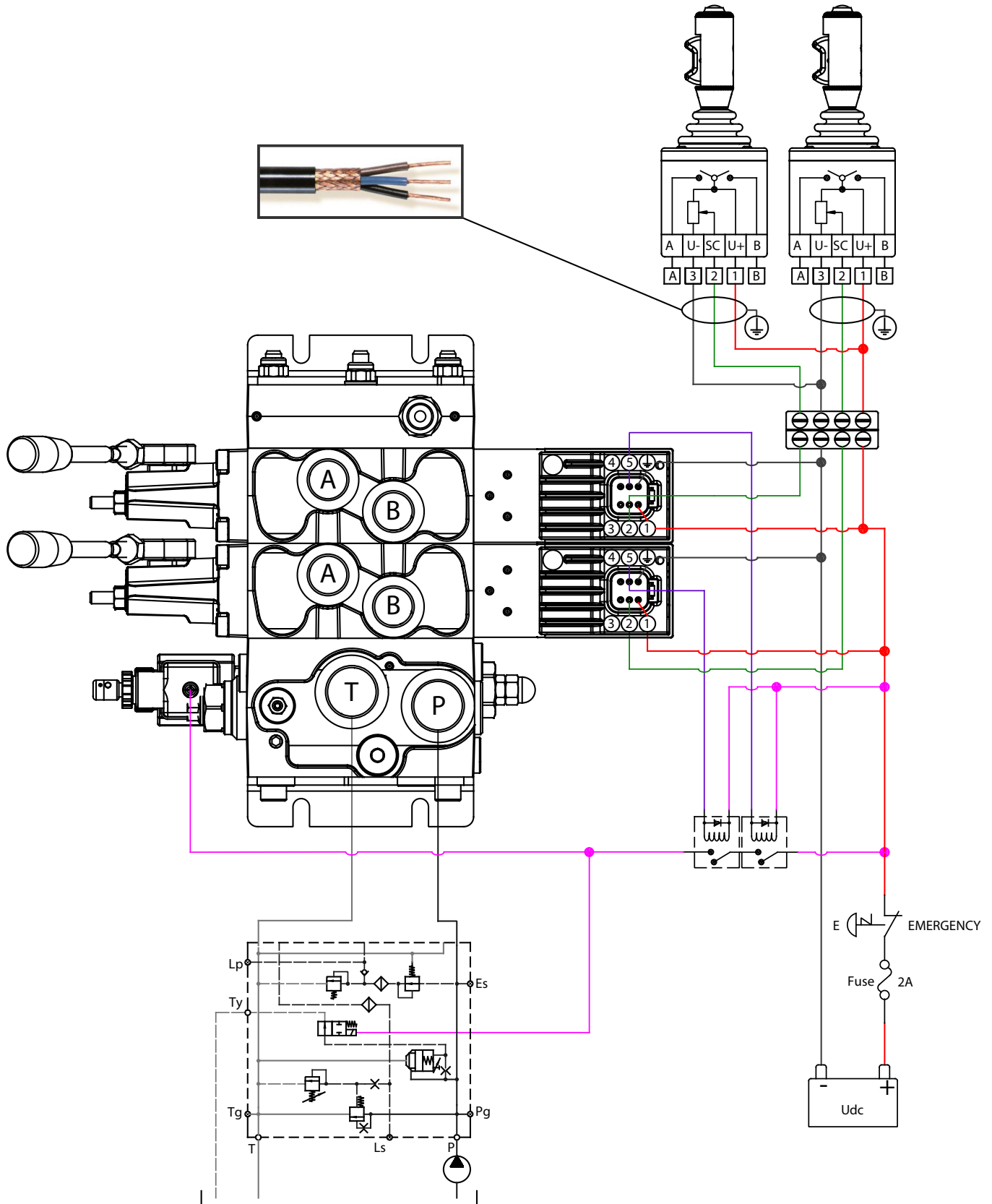

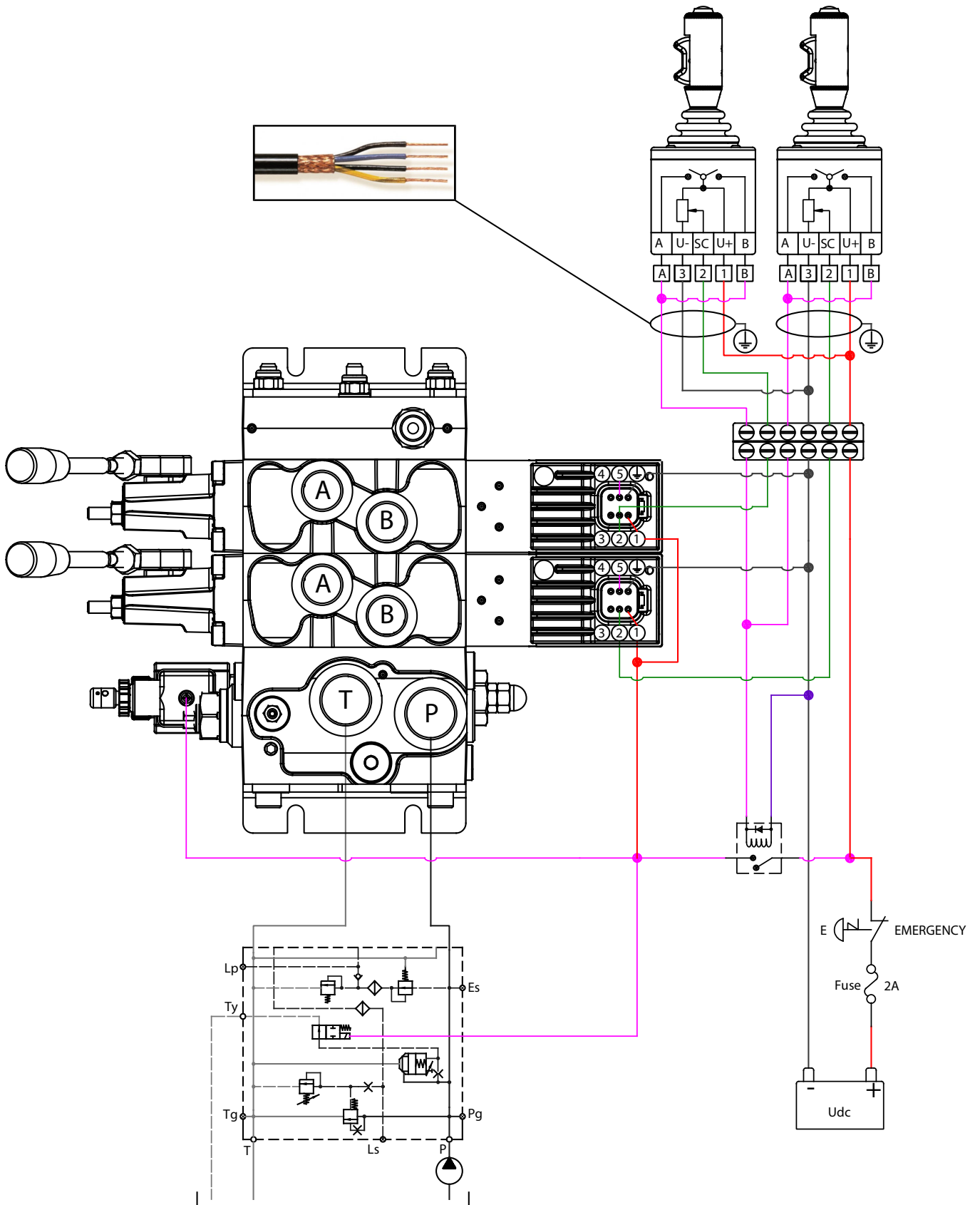

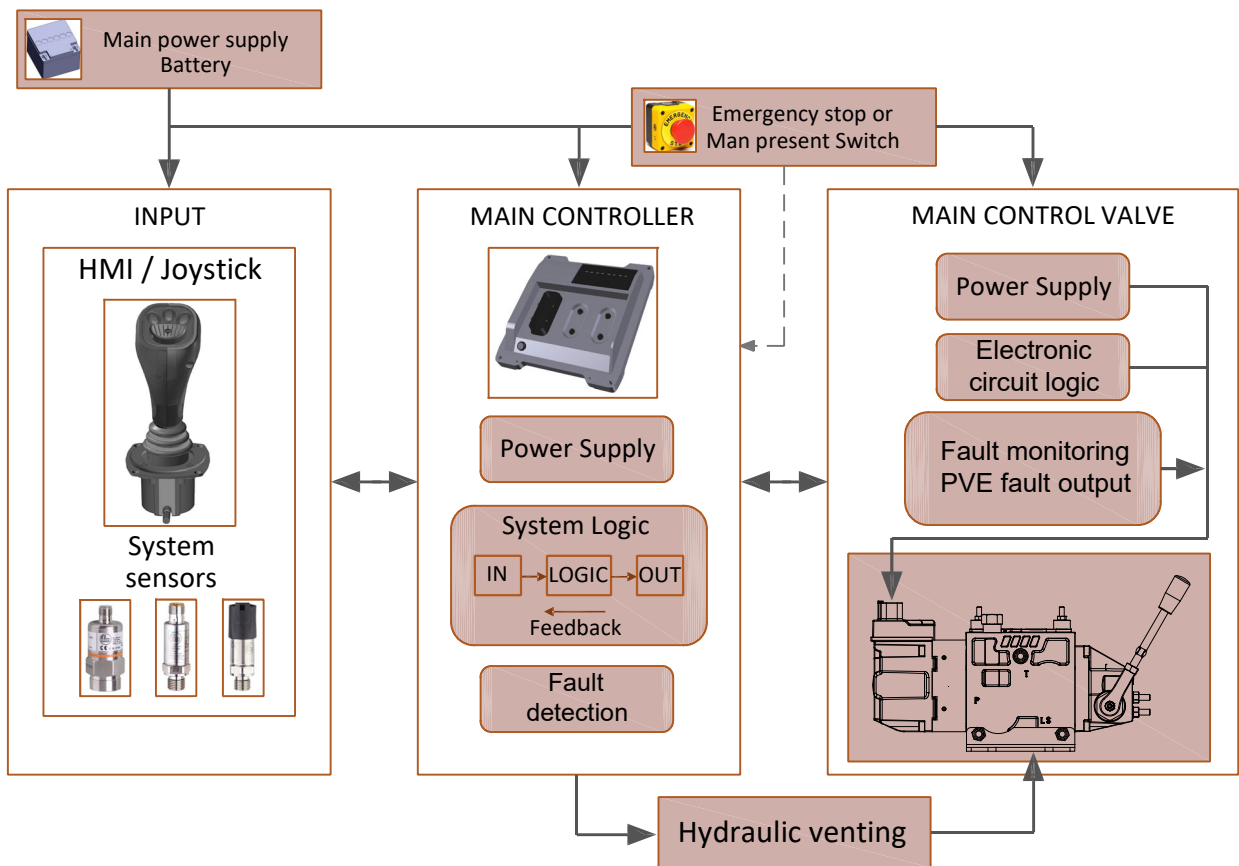

PDV74 - PEAC111 Electro-hydraulic proportional actuation
Electrical wiring diagram with OMFB I/O controller
 Input signal 0,5 Udc

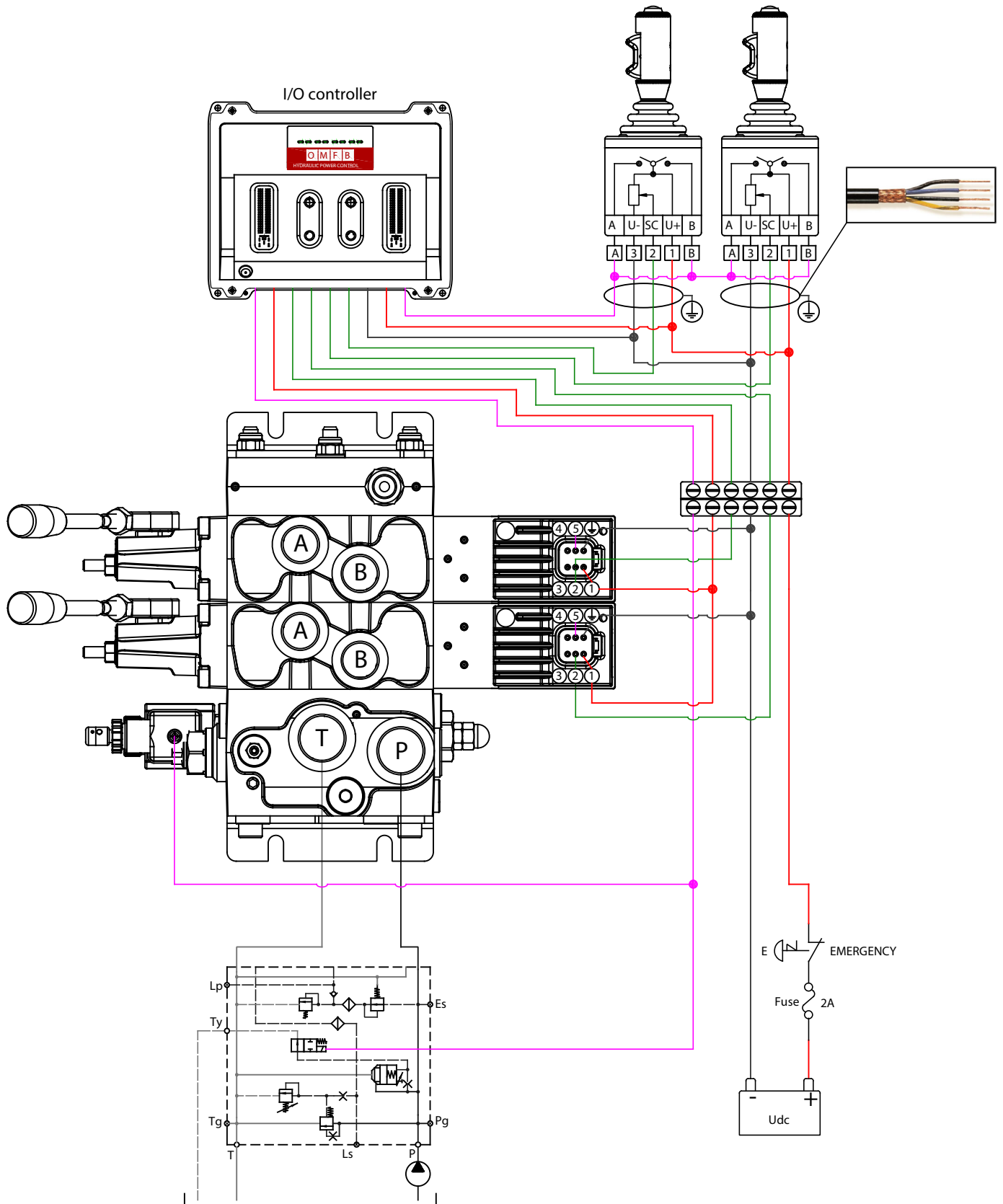

PDV74 - PEAC111 Electro-hydraulic proportional actuation
Electrical wiring diagram with OMFB I/O controller
 Input signal 0,5 Udc

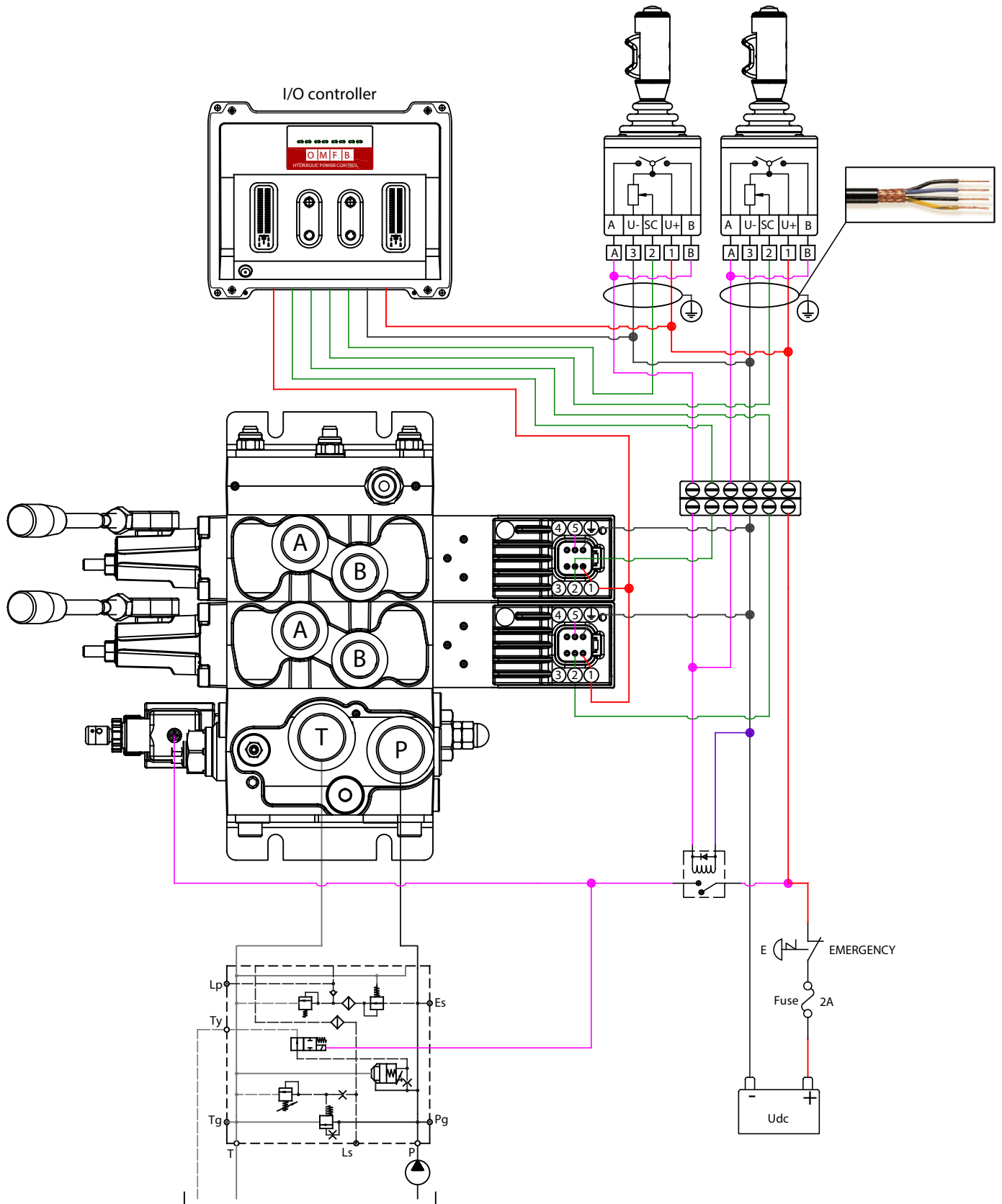

PDV74 - PEAC112 Electro-hydraulic proportional actuation
Closed loop spool control, high performance resolution
Input signal control 0 ÷ 10 V

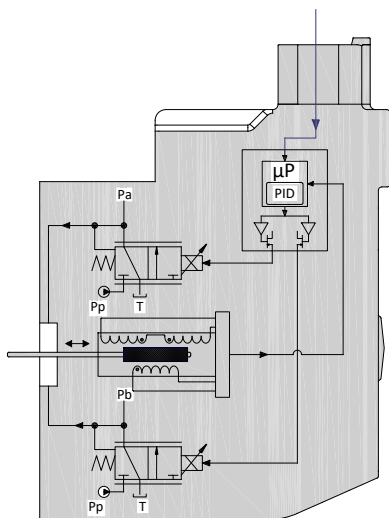
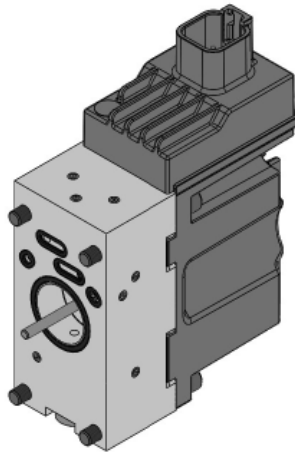

PEAC112 is a proportional high performance PDV spool actuation with integrated electronics and inductive transducer (LVDT) that operates safely and precisely the main spool movement according to an electrical signal coming from a remote control.

The input signal by means of the PCB and the two proportional pressure reducing valves, determines the level of the pilot pressure which moves the main spool.

The spool position is detected in the LVDT transducer which generates an electric feed-back signal registered by the electronics. The variation between the input signal and the feed-back signal, actuates the solenoid valves accordingly, so that, the hydraulic pilot pressure will drive the main spool in the right position.

All PEAC112 modules comes with integrated fault monitoring system, available in two version:

- Active version
- Passive version

Active fault monitoring

When an error state is detected, the two proportional solenoid valves will be automatically deactivated, a red lamp will light-up and drive the spool in neutral position (if it's not seized up). The system will only react to failures of more than 500 ms (in other words there is delay of half a second before anything happens). An alarm signal is sent out through the connector, and minus is opened.

This error state is memorized, and continues until the system is being reset by switching off the supply voltage.

Shortly, when the active fault monitoring system is connected and an error state is detected, the system ensures a fast and operator free reaction, that will put the complete hydraulic circuit into venting conditions, thus preventing uncontrollable machine movements.

Passive fault monitoring

When an error state is detected, the two proportional solenoid valves will not be deactivated, a red lamp will light-up, but still control the main spool.

When a fault condition occurs, after a delay of 250 ms an alarm signal is sent out through a devoted pin

This state is not memorized, and when the faulty state disappears, the alarm signal will turn to passive again.

In order to prevent the electronic from going into an undefined state, any time the system is being triggered or reset, a general check of power supply and the internal clock frequency is made.

The use of PEAC112 module both passive or active version, allows the machines hydraulic system to be made with different level of safety degree that for the choice of which it is essential to know the exactly required functions.

When the PEAC112 module active version is connected with the pump unloading system, the level of safety degree protection for the complete hydraulic system becomes very high, operator free, and helps OEM to meet the PL (Performance Level) required to be comply with the safety demands of Machinery Directive 2006/42/EC.

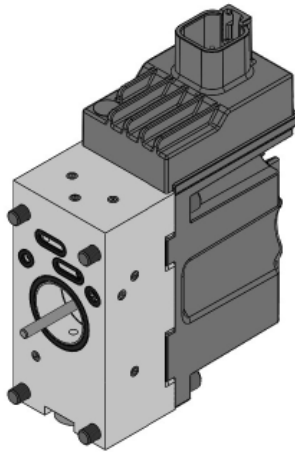

PEAC112 is defined by:

- Inductive transducer with resolution < 12 µm
- Integrated diagnosis and error memory
- Fault monitoring transistor output for signal source
- Higher spool control accuracy
- EMC performance to
- Low hysteresis
- Quicker reaction time
- Spool direction movement output
- Integrated PWM/Pulse Width Modulation
- Low electrical power

PEAC112 Technical data		
Rated supply voltage	10-30 Vdc	
Max ripple	5%	
Signal control	0-10 V	
Range control signal	2,5 V to 7,5 V	
Neutral spool position	5 V	
Max threshold signal, A port	1 V	
Max threshold signal, B port	1 V	
Max current signal @ rated voltage	48 mA	
Input capacitor	100 nF	
Signal control impedance	25 kΩ	
Power consumption	8,7 W	
Heat insulation	Class H (180°C)	
Duty cycle	ED 100%	
Max current consumption	650 mA	
Current consumption in neutral position	80 mA	
Coil impedance @ 20°C	8,9 Ω	
Dither frequency	50-200 Hz	
Recommended frequency	100 Hz	
Enclouser degree	(Electrical wiring excepted) IP 66 - IP 67 - IP 69K	
Weight cast iron body	1,8 kg	
Weight aluminium body	1,3 kg	
Bootloader function, debugging parameters and set-up function available only with Deutsch connector DT06-6S		
Fault monitoring system	Max current on safety output (pin 5)	50 mA
	Reaction time a fault	500 ms
Max current output signal for spool direction movement		50 mA
Reaction time (constant voltage)	From neutral position to max spool travel	110 - 140 ms
	From max spool travel to neutral	70 - 90 ms
Reaction time (neutral switch)	From neutral position to max spool travel	130 - 170 ms
	From max spool travel to neutral	70 - 90 ms

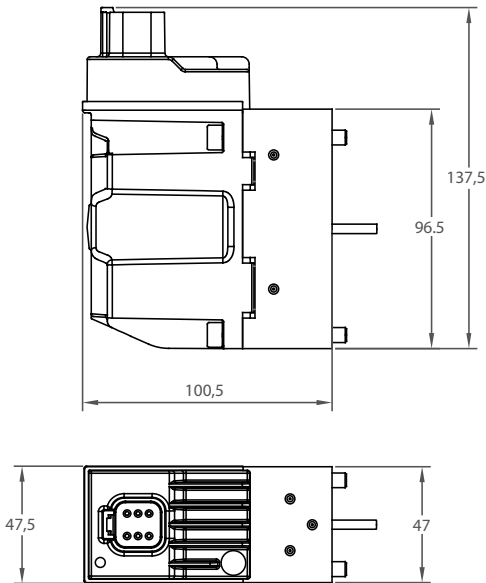

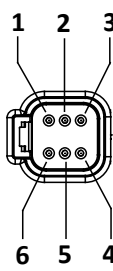
Deutsch connector DT06-6S Enclosure degree IP 69K PIN-assignment			
	1	Power supply	
	2	Input signal control	
	3	CAN-high	A port-spool movement signal
	4	CAN-low	B port-spool movement signal
	5	Fault monitoring signal	
	6	Ground	

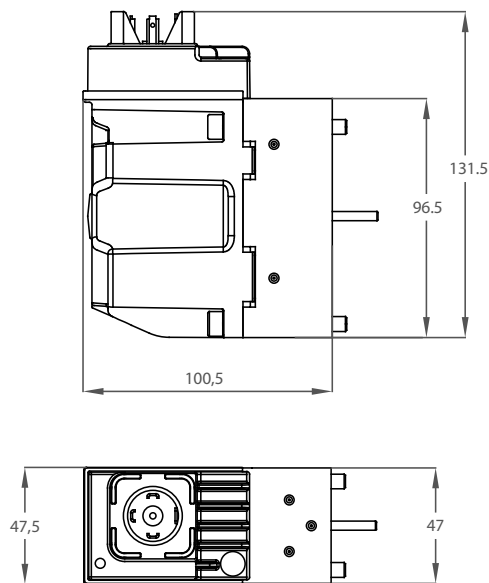

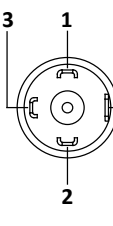
Hirschmann connector DIN 43650 Enclosure degree IP 65 PIN-assignment			
	1	Power supply	
	2	Input signal control	
	3	Fault monitoring signal	
	4	Ground	

Connector version	Code numbers			
	Active version		Passive version	
	Cast-iron body	Aluminium body	Cast-iron body	Aluminium body
Deutsch DT06-6S	PEAC0122000	PEAC1122000	PEAC0112000	PEAC1112000
DIN 43650	PEAC0122200	PEAC1122200	PEAC0112200	PEAC1112200

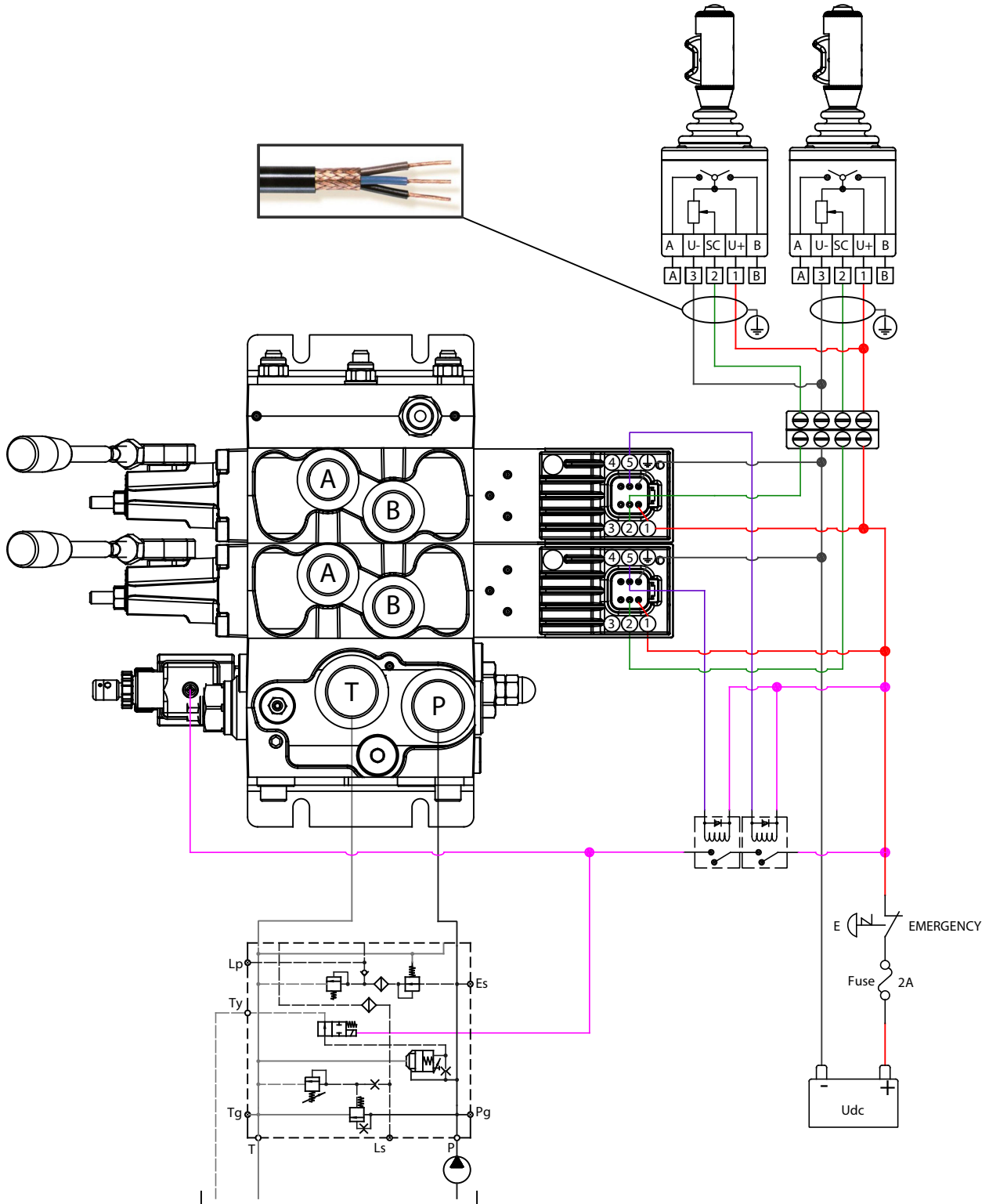

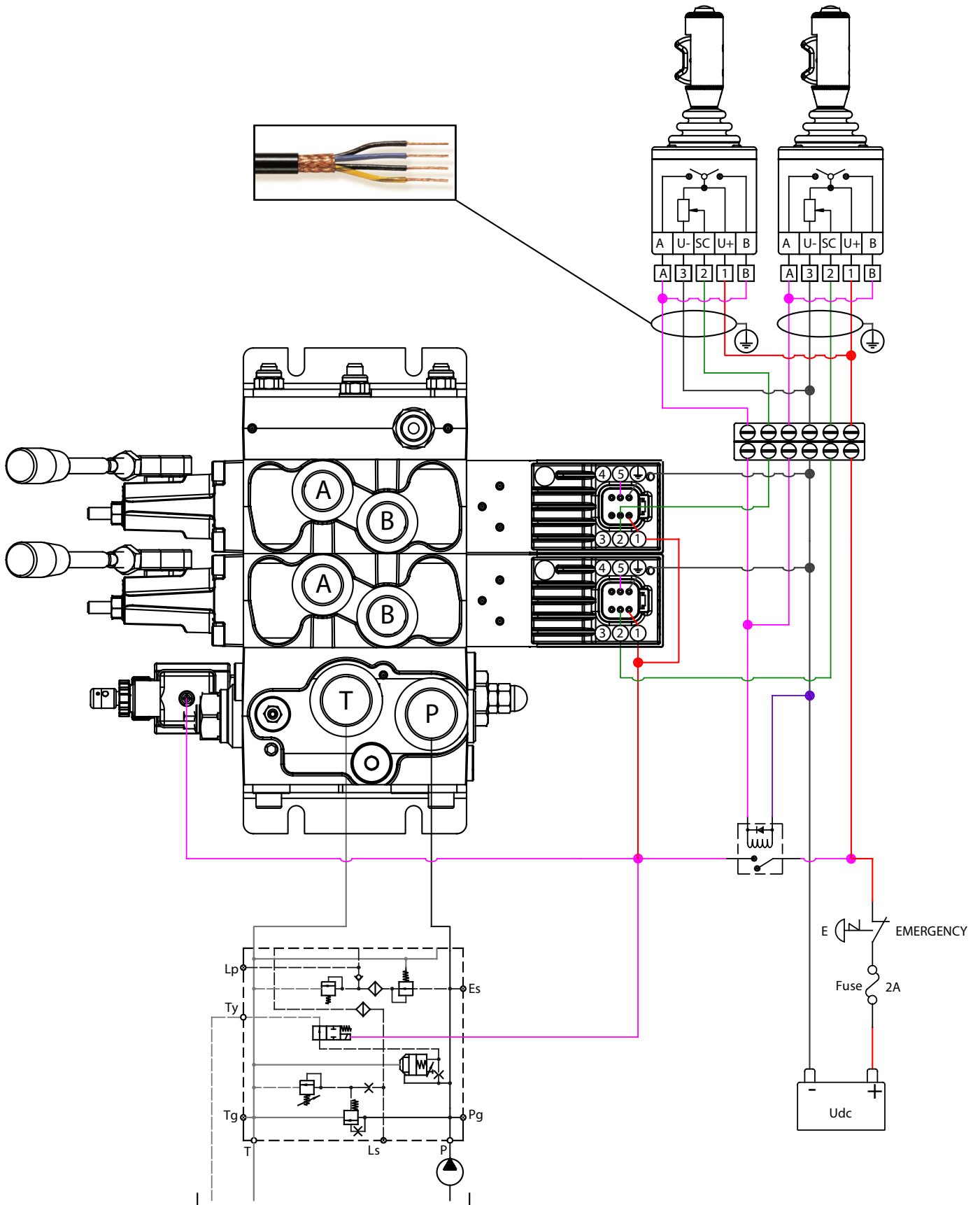

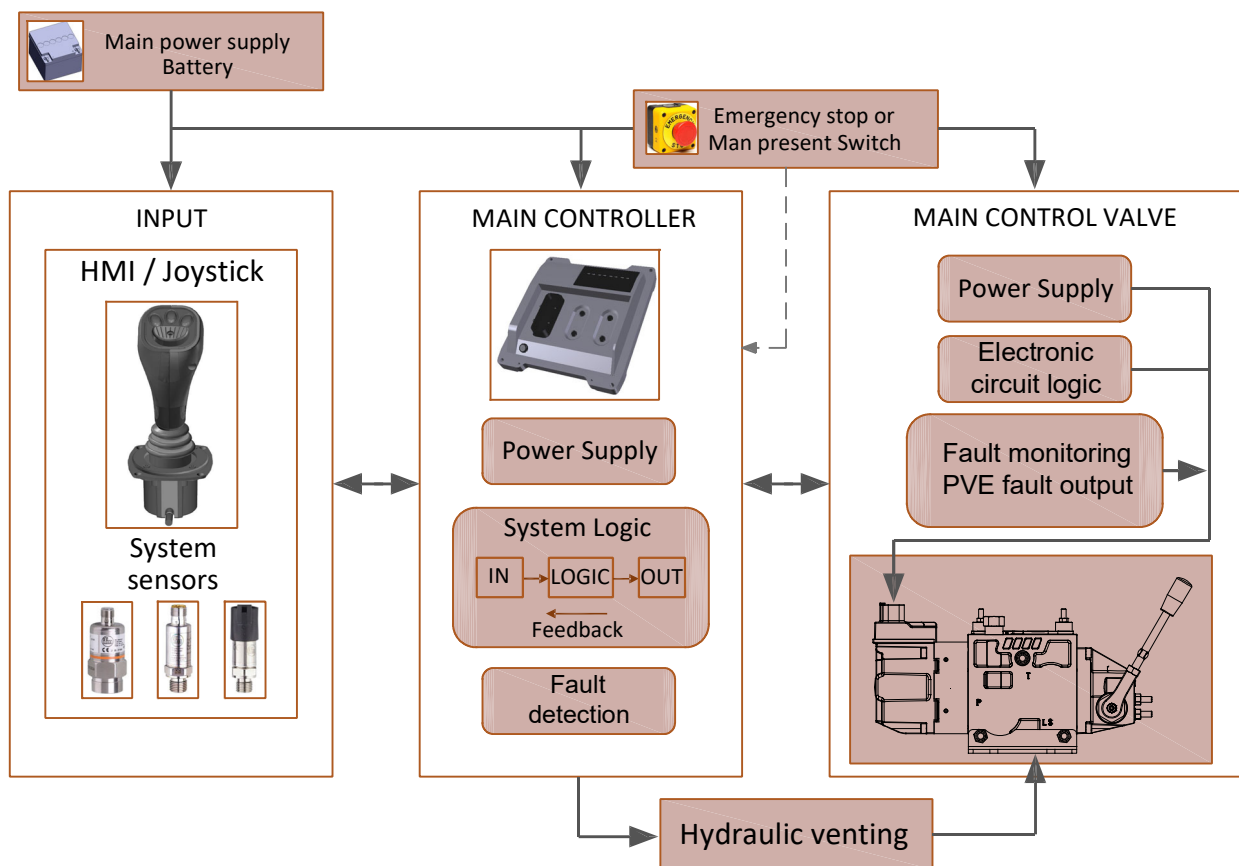

PDV74 - PEAC112 Electro-hydraulic proportional actuation
Electrical wiring diagram with OMFB I/O controller
 Input signal 0 ÷ 10 V

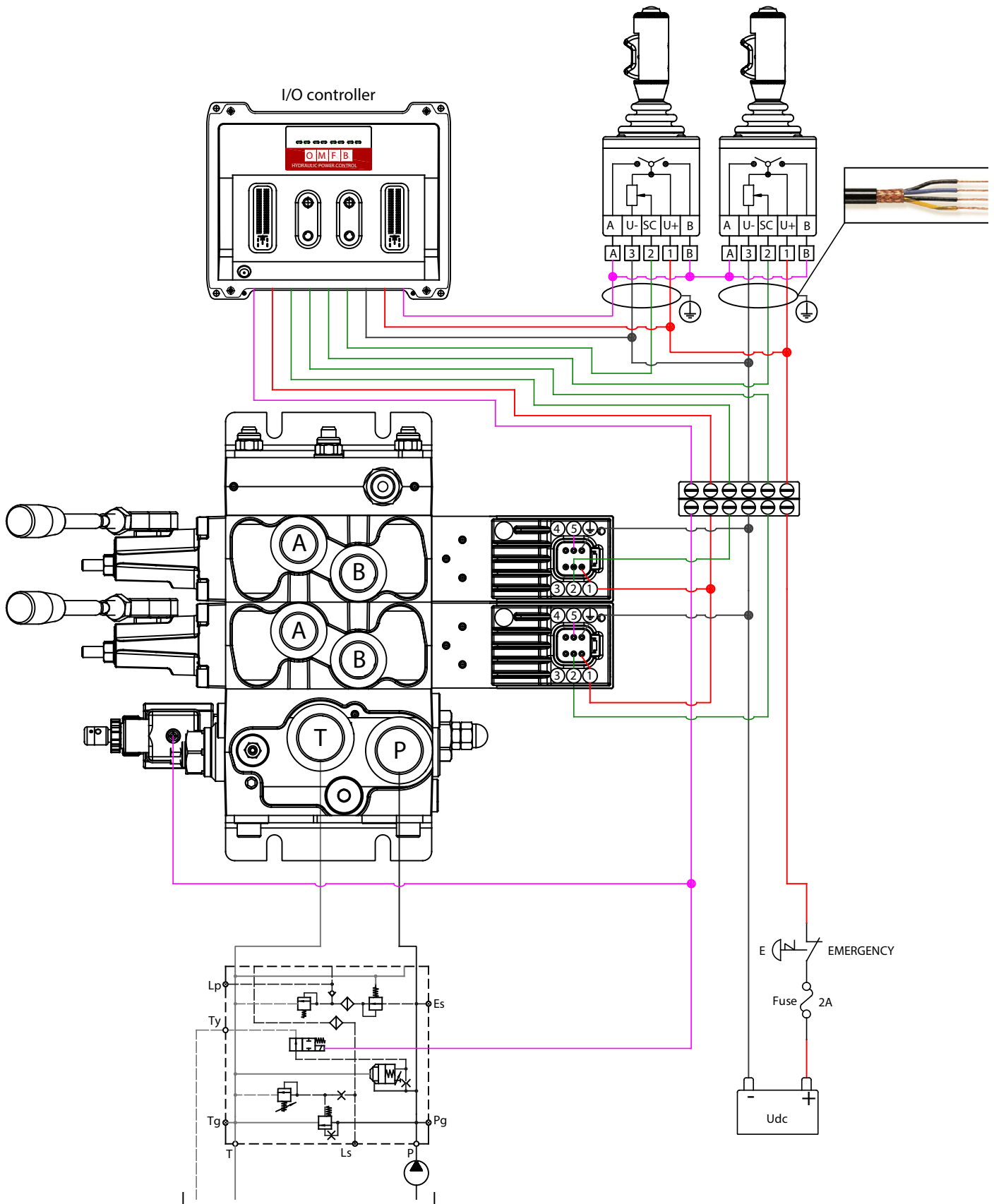

PDV74 - PEAC112 Electro-hydraulic proportional actuation
Electrical wiring diagram with OMFB I/O controller
 Input signal 0 ÷ 10 V

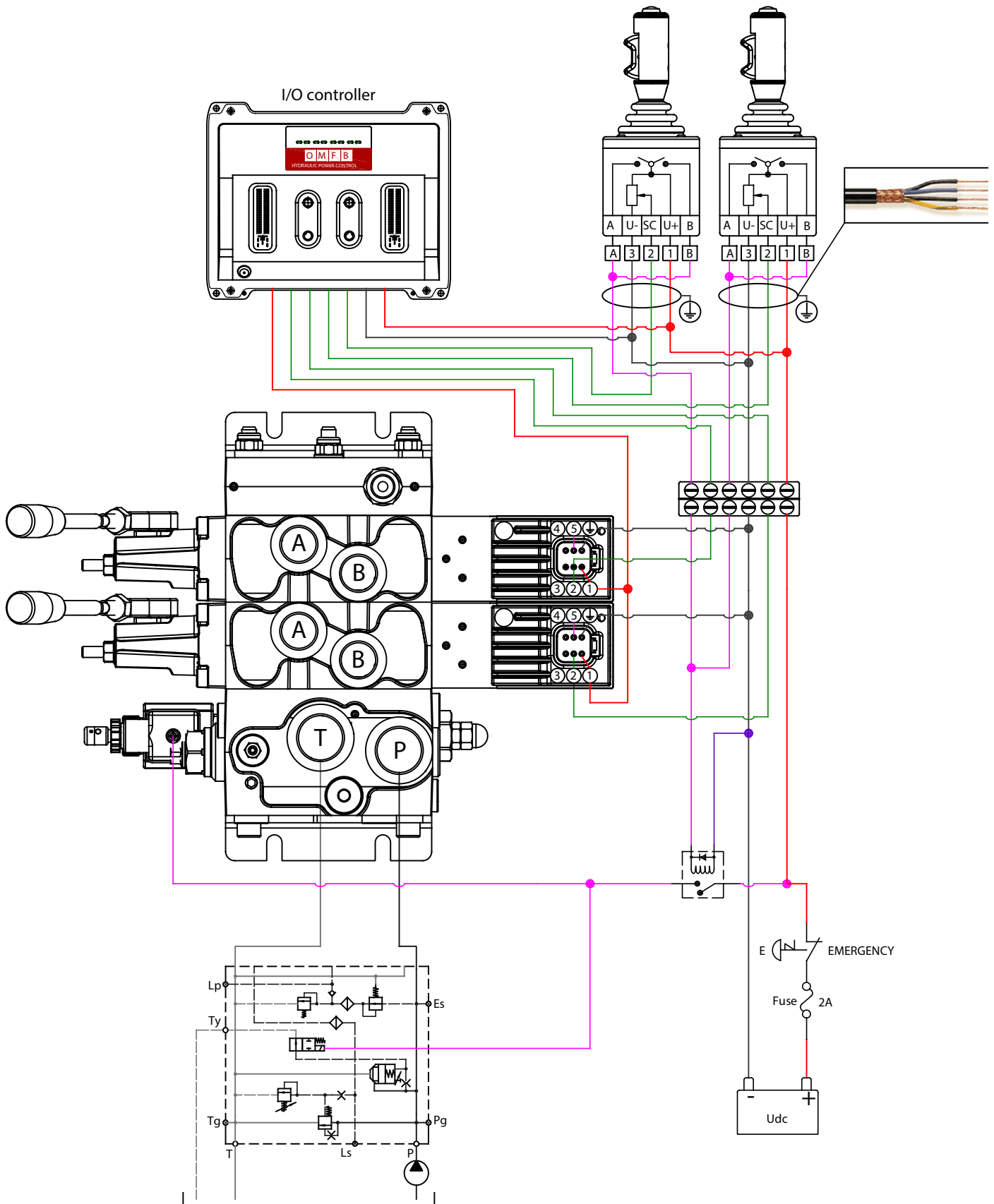

PDV74 - PEAC116 Electro-hydraulic proportional actuation
Closed loop spool control, high performance resolution
Input signal 4 ÷ 20 mA

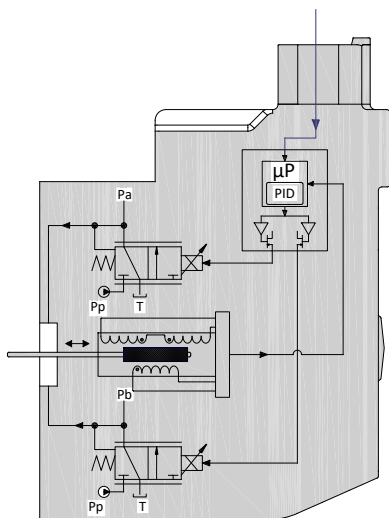
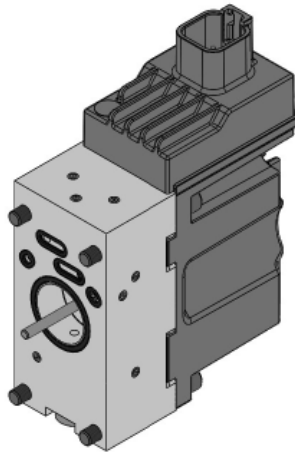

PEAC116 is a proportional high performance PDV spool actuation with integrated electronics and inductive transducer (LVDT) that operates safely and precisely the main spool movement according to an electrical signal coming from a remote control.

The input signal by means of the PCB and the two proportional pressure reducing valves, determines the level of the pilot pressure which moves the main spool.

The spool position is detected in the LVDT transducer which generates an electric feed-back signal registered by the electronics. The variation between the input signal and the feed-back signal, actuates the solenoid valves accordingly, so that, the hydraulic pilot pressure will drive the main spool in the right position.

All PEAC116 modules comes with integrated fault monitoring system, available in two version:

- Active version
- Passive version

Active fault monitoring

When an error state is detected, the two proportional solenoid valves will be automatically deactivated, a red lamp will light-up and drive the spool in neutral position (if it's not seized up). The system will only react to failures of more than 500 ms (in other words there is delay of half a second before anything happens). An alarm signal is sent out through the connector, and minus is opened.

This error state is memorized, and continues until the system is being reset by switching off the supply voltage.

Shortly, when the active fault monitoring system is connected and an error state is detected, the system ensures a fast and operator free reaction, that will put the complete hydraulic circuit into venting conditions, thus preventing uncontrollable machine movements.

Passive fault monitoring

When an error state is detected, the two proportional solenoid valves will not be deactivated, a red lamp will light-up, but still control the main spool.

When a fault condition occurs, after a delay of 250 ms an alarm signal is sent out through a devoted pin

This state is not memorized, and when the faulty state disappears, the alarm signal will turn to passive again.

In order to prevent the electronic from going into an undefined state, any time the system is being triggered or reset, a general check of power supply and the internal clock frequency is made.

The use of PEAC116 module both passive or active version, allows the machines hydraulic system to be made with different level of safety degree that for the choice of which it is essential to know the exactly required functions.

When the PEAC116 module active version is connected with the pump unloading system, the level of safety degree protection for the complete hydraulic system becomes very high, operator free, and helps OEM to meet the PL (Performance Level) required to be comply with the safety demands of Machinery Directive 2006/42/EC.

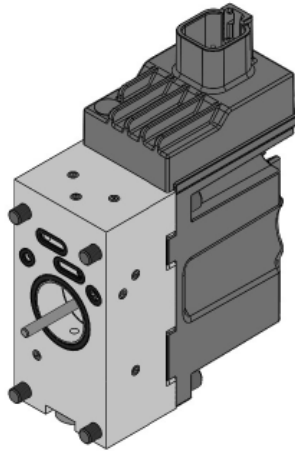

PEAC116 is defined by:

- Inductive transducer with resolution < 12 µm
- Integrated diagnosis and error memory
- Fault monitoring transistor output for signal source
- Higher spool control accuracy
- EMC performance according to Directive 2014/30/UE
- Low hysteresis
- Quicker reaction time
- Spool direction movement output
- Integrated PWM/Pulse Width Modulation
- Low electrical power
- Robust and reliable design

PEAC116 Technical data		
Rated supply voltage	10 ÷ 30 Vdc	
Max ripple	5%	
Signal control	4 ÷ 20 mA	
Range control signal	4 mA to 20 mA	
Neutral spool position	12 mA	
Max threshold signal, A port	1,5 mA	
Max threshold signal, B port	1,5 mA	
Max current signal @ rated voltage	48 mA	
Input capacitor	100 nF	
Signal control impedance	220 Ω	
Power consumption	8,7 W	
Heat insulation	Class H (180°C)	
Duty cycle	ED 100%	
Max current consumption	650 mA	
Current consumption in neutral position	80 mA	
Coil impedance @ 20°C	8,9 Ω	
Dither frequency	50 ÷ 200 Hz	
Recommended frequency	100 Hz	
Enclosure degree	(Electrical wiring excepted) IP65 - IP66 - IP69K	
Weight cast iron body	1,8 kg	
Weight aluminium body	1,3 kg	
Bootloader function, debugging parameters and set-up function available with Deutsch connector DT06-6S, only		
Fault monitoring system	Max current on safety output (pin 5)	50 mA
	Reaction time a fault	500 ms
Max current output signal for spool direction movement		50 mA
Reaction time (constant voltage)	From neutral position to max spool travel	110 ÷ 140 ms
	From max spool travel to neutral	70 ÷ 90 ms
Reaction time (neutral switch)	From neutral position to max spool travel	130 ÷ 170 ms
	From max spool travel to neutral	70 ÷ 90 ms

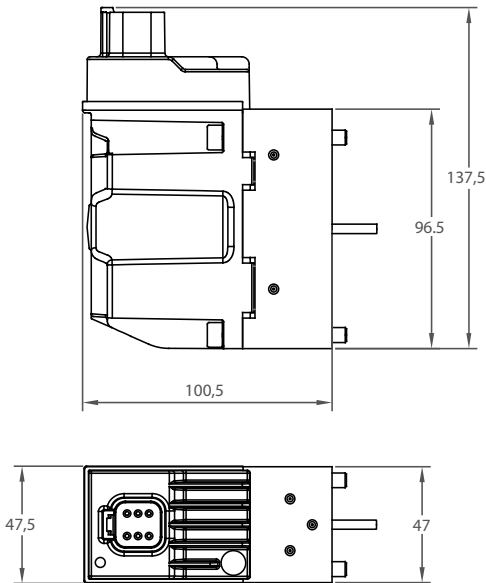

Deutsch connector DT06-6S Enclosure degree IP 69K PIN-assignment			
	1	Power supply	
	2	Input signal control	
	3	CAN-high	A port-spool movement signal
	4	CAN-low	B port-spool movement signal
	5	Fault monitoring signal	
	6	Ground	

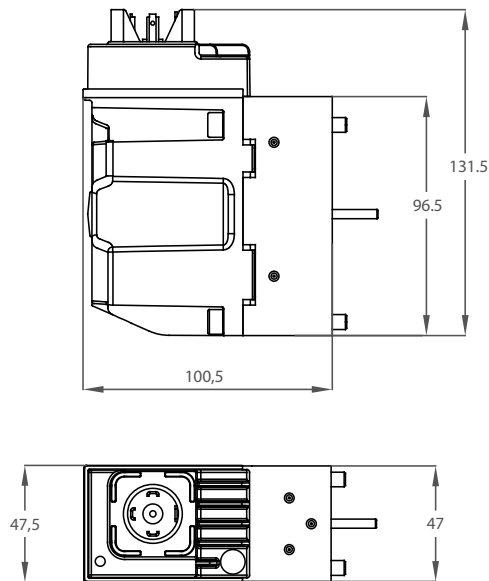

Hirschmann connector DIN 43650 Enclosure degree IP 65 PIN-assignment			
	1	Power supply	
	2	Input signal control	
	3	Fault monitoring signal	
	4	Ground	

Connector version	Code numbers			
	Active version		Passive version	
	Cast-iron body	Aluminium body	Cast-iron body	Aluminium body
Deutsch DT06-6S	PEAC0126000	PEAC1126000	PEAC0116000	PEAC1116000
DIN 43650	PEAC0126200	PEAC1126200	PEAC0116200	PEAC1116200

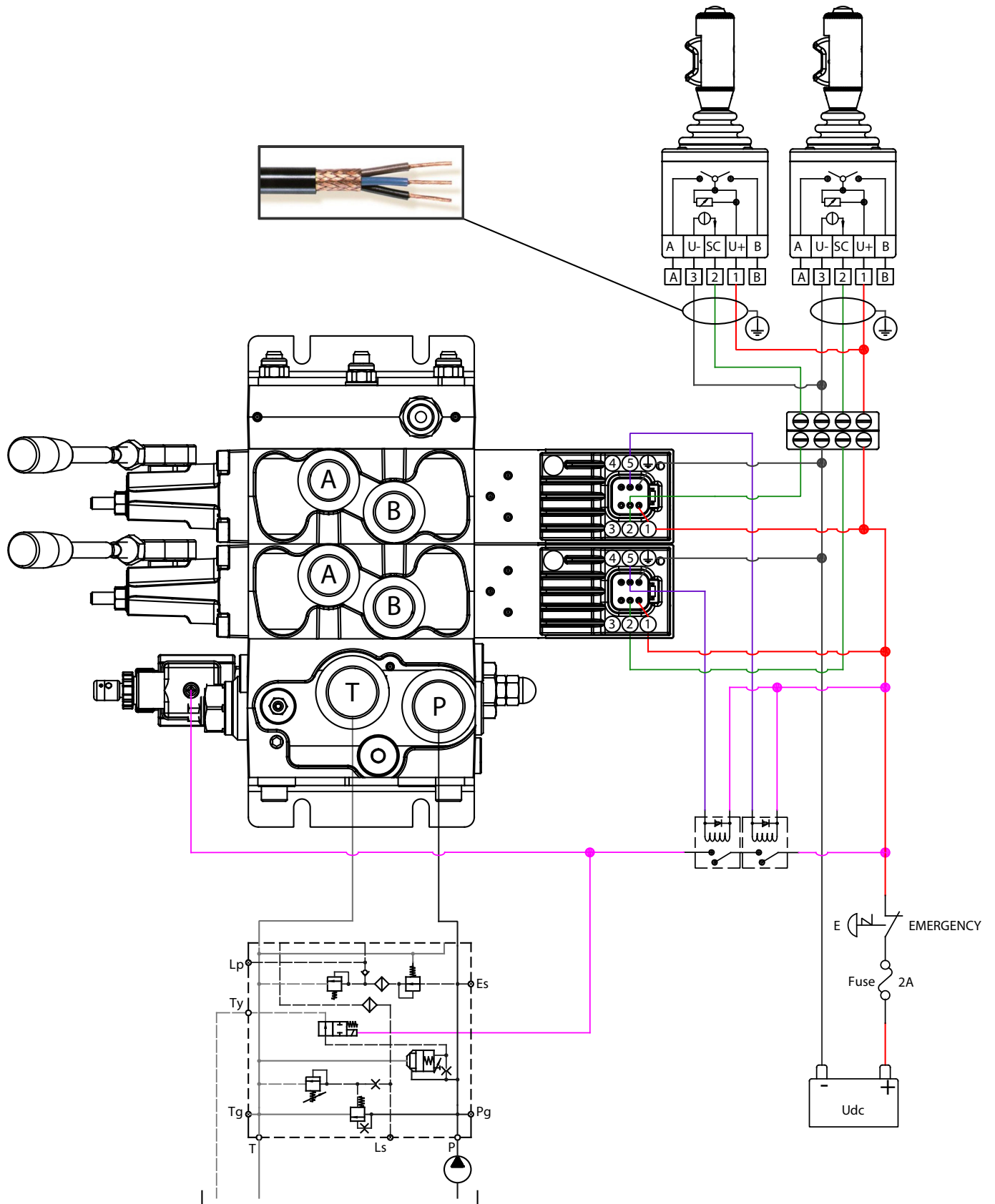

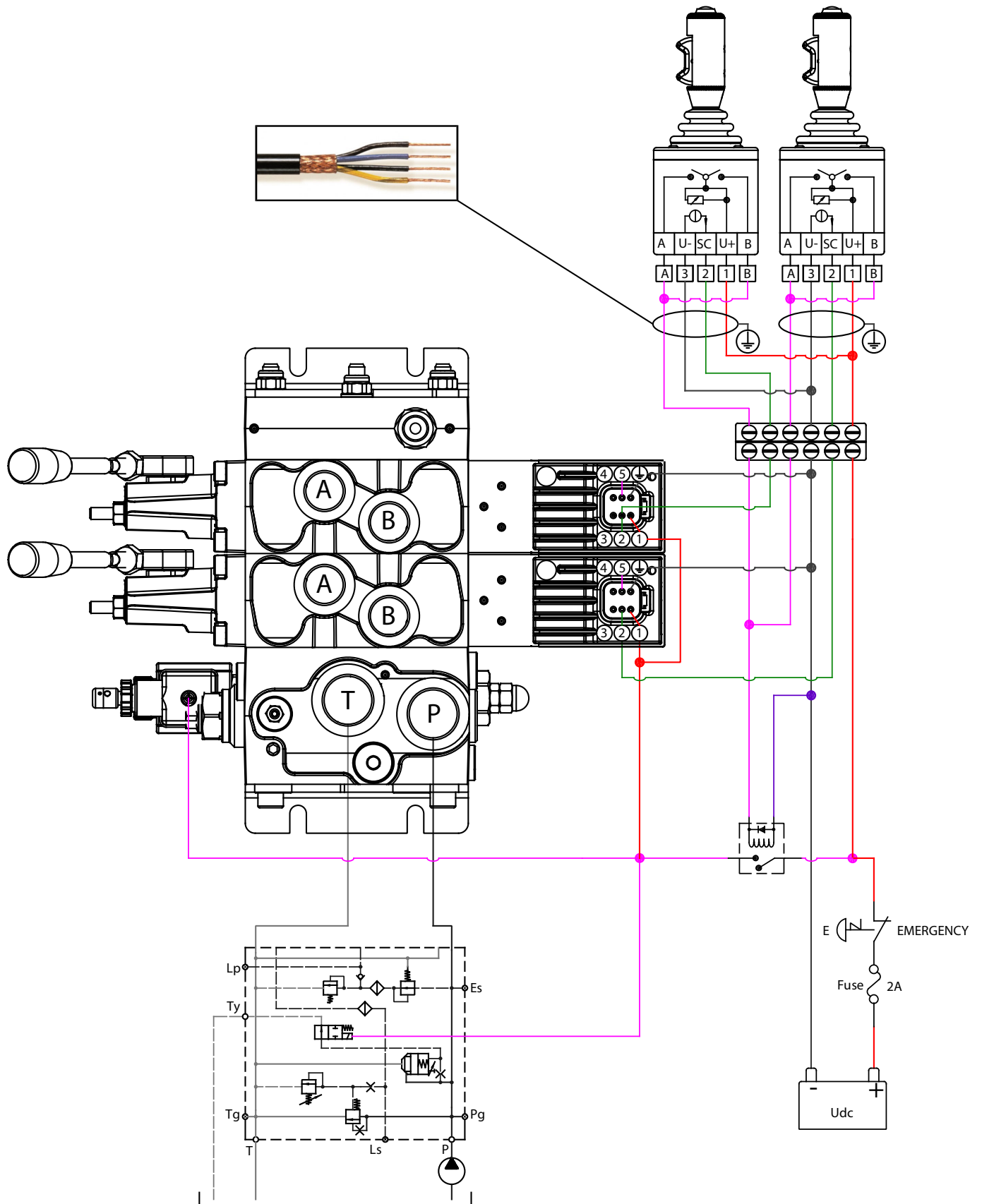

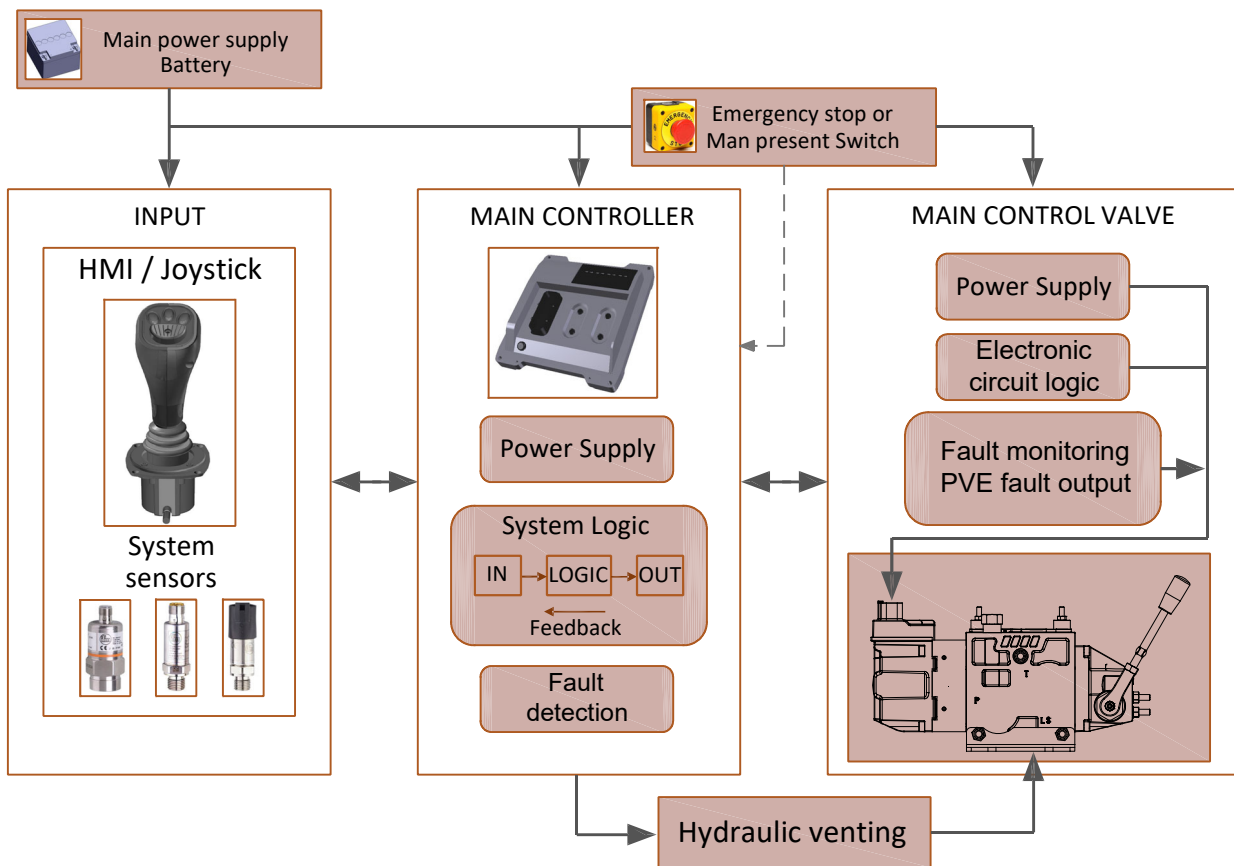

PDV74 - PEAC116 Electro-hydraulic proportional actuation.
Electrical wiring with OMFB I/O controller
 Input signal 4 ÷ 20 mA

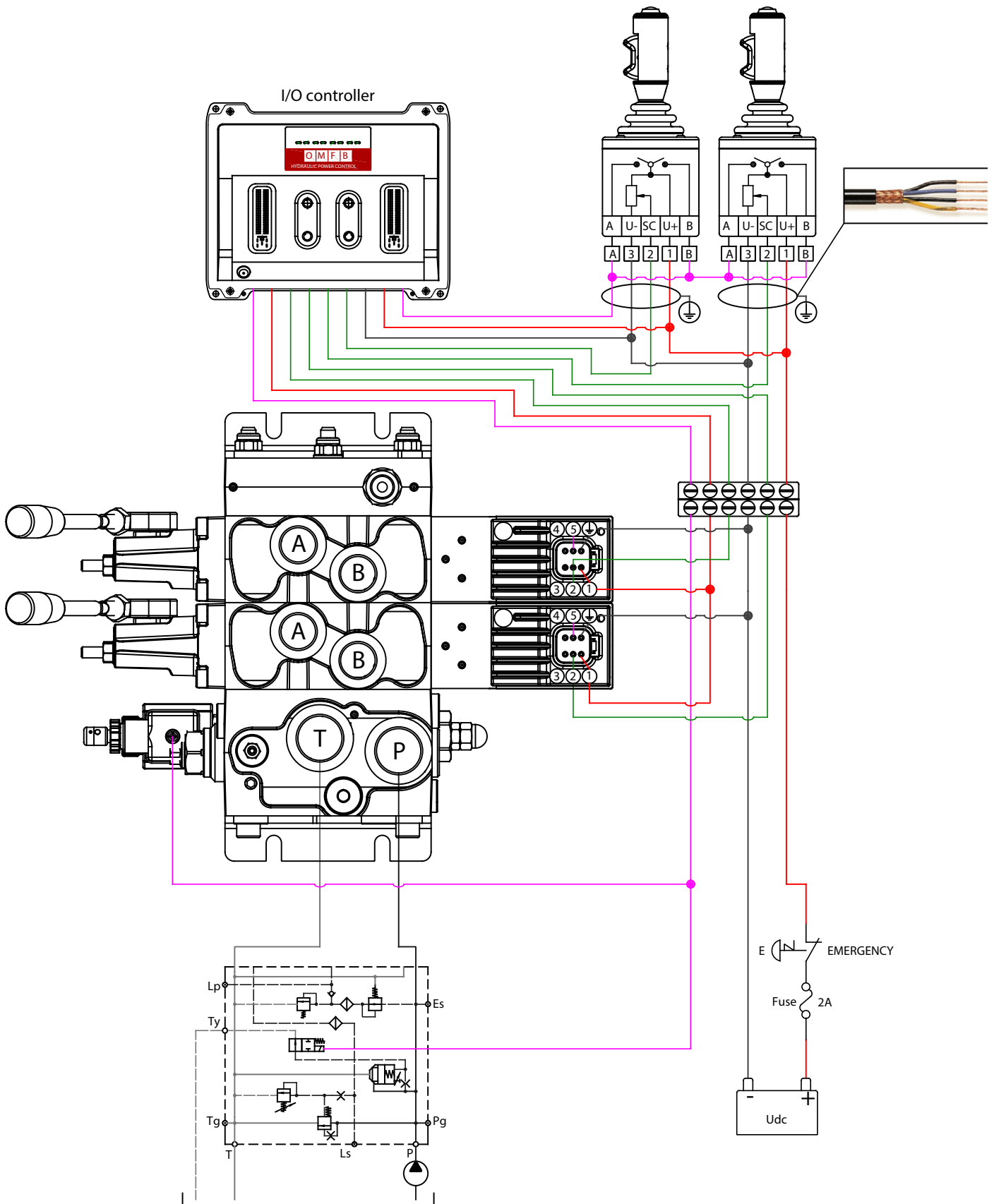

PDV74 - PEAC116 Electro-hydraulic proportional actuation
Electrical wiring diagram with OMFB I/O controller
 Input signal 4 ÷ 20 mA

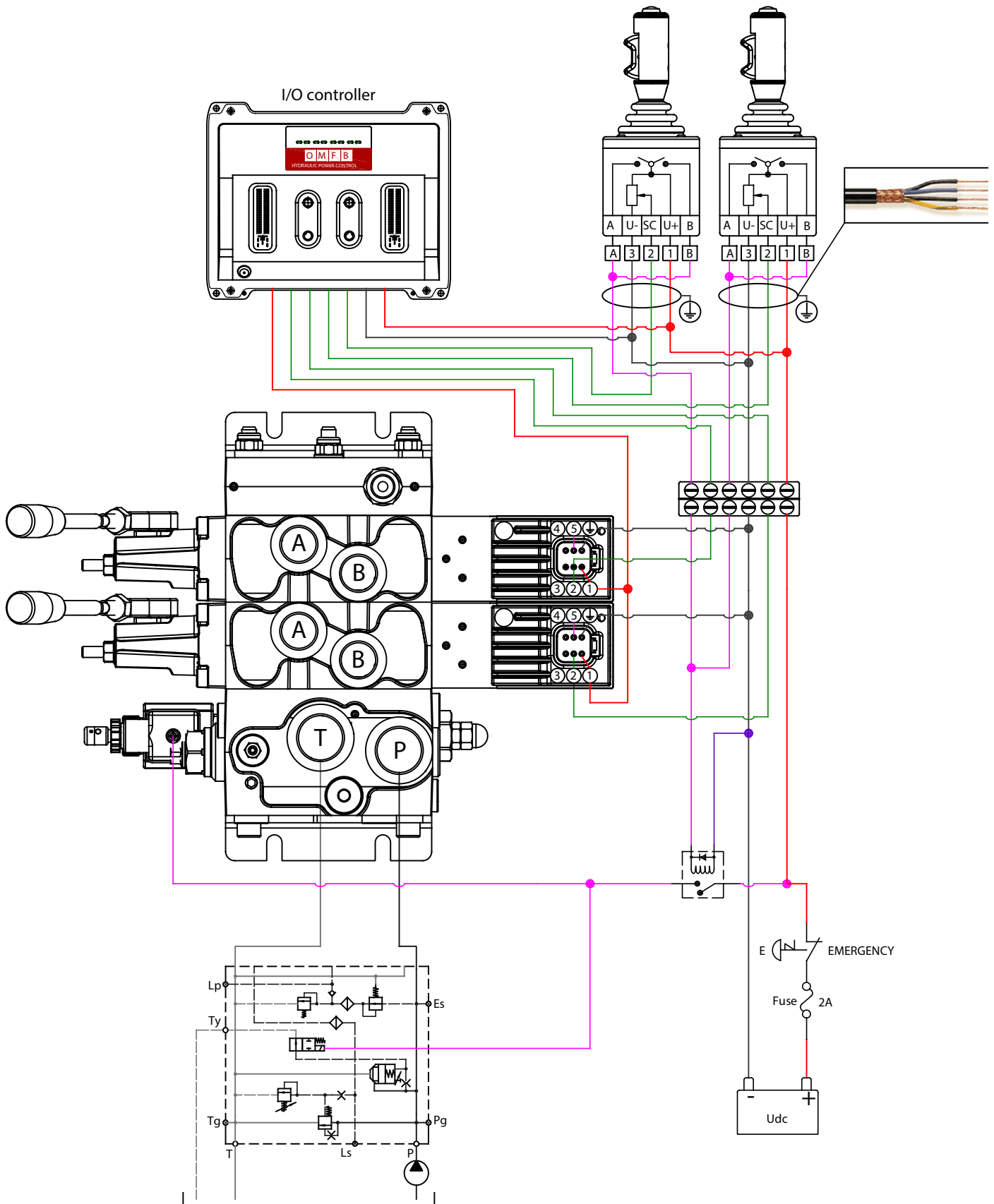

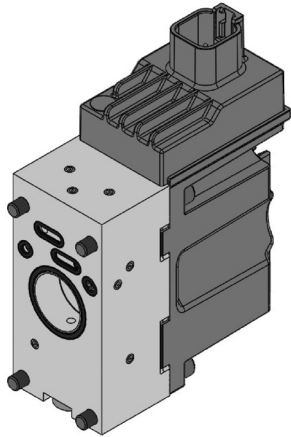

PEAC011 is a proportional open loop spool actuation with integrated electronics that operates the main spool movement according to an electrical signal coming from a remote control.

The input signal by means of the PCB and the two proportional pressure reducing valves, determines the level of the pilot pressure which moves the main spool.

PEAC011 does not have neither the transducer spool position control nor fault monitoring system, this means that any forces which override the pilot pressure spool forces, may change the spool position with no error signal, and the safety of the whole system is left to the operator's visual control, only.

PEAC011 is recommended where a simple proportional control is required, and where hysteresis and reaction time are not so critical.

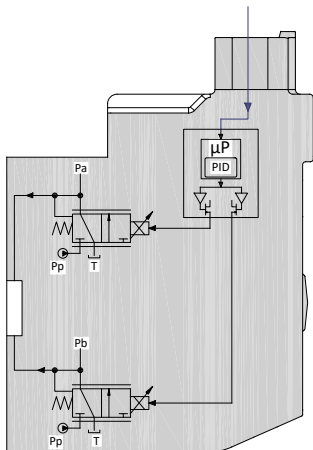

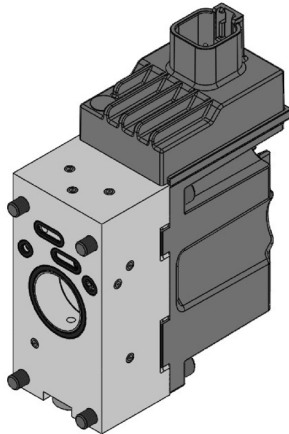

PEAC011 is defined by:

- High spool control accuracy
- EMC performace according to Directive 2014/30/UE
- Quick reaction time
- Integrated PWM/Pulse Width Modulation
- Low electrical power
- Robust and reliable design

PEAC011 Technical data		
Rated supply voltage	10-30 Vdc	
Max ripple	5%	
Signal control	0,5 Udc	
Range control signal	0,25 Udc to 0,75 Udc	
Neutral spool position	0,5 Udc	
Max threshold signal, A port	1 V	
Max threshold signal, B port	1 V	
Max current signal @ rated voltage	48 mA	
Input capacitor	100 nF	
Signal control impedance	25 kΩ	
Power consumption	8,7 W	
Heat insulation	Class H (180°C)	
Duty cycle	ED 100%	
Max current consumption	650 mA	
Current consumption in neutral position	80 mA	
Coil impedance @ 20°C	8,9 Ω	
Dither frequency	50-200 Hz	
Recommended frequency	100 Hz	
Enclouser degree	(Electrical wiring excepted)	
	IP 66 - IP 67 - IP 69K	
Weight cast iron body	1,8 kg	
Weight aluminium body	1,3 kg	
Bootloader function, debugging parameters and set-up function available only with Deutsch connector DT06-6S		
Reaction time (constant voltage)	From neutral position to max spool travel	110 - 140 ms
	From max spool travel to neutral	70 - 90 ms
Reaction time (neutral switch)	From neutral position to max spool travel	130 - 170 ms
	From max spool travel to neutral	70 - 90 ms

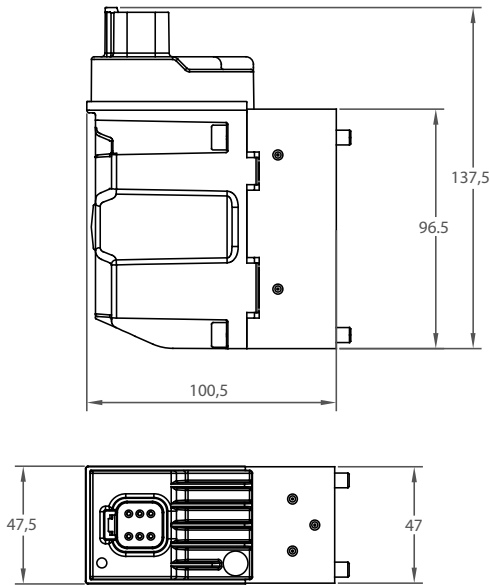

Deutsch connector DT06-6S Enclosure degree IP 69K PIN-assignment		
	1	Power supply
	2	Input signal control
	3	CAN-high
	4	CAN-low
	5	Free
	6	Ground

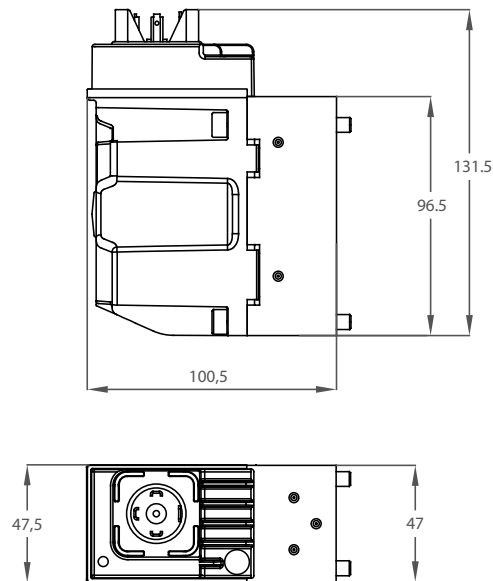

Hirschmann connector DIN 43650 Enclosure degree IP 65 PIN-assignment		
	1	Power supply
	2	Input signal control
	3	Free
	4	Ground

Connector version	Code numbers			
	Active version		Passive version	
	Cast-iron body	Aluminium body	Cast-iron body	Aluminium body
Deutsch DT06-6S	PEAC0021000	PEAC1021000	PEAC0011000	PEAC1011000
DIN 43650	PEAC0021200	PEAC1021200	PEAC0011200	PEAC1011200

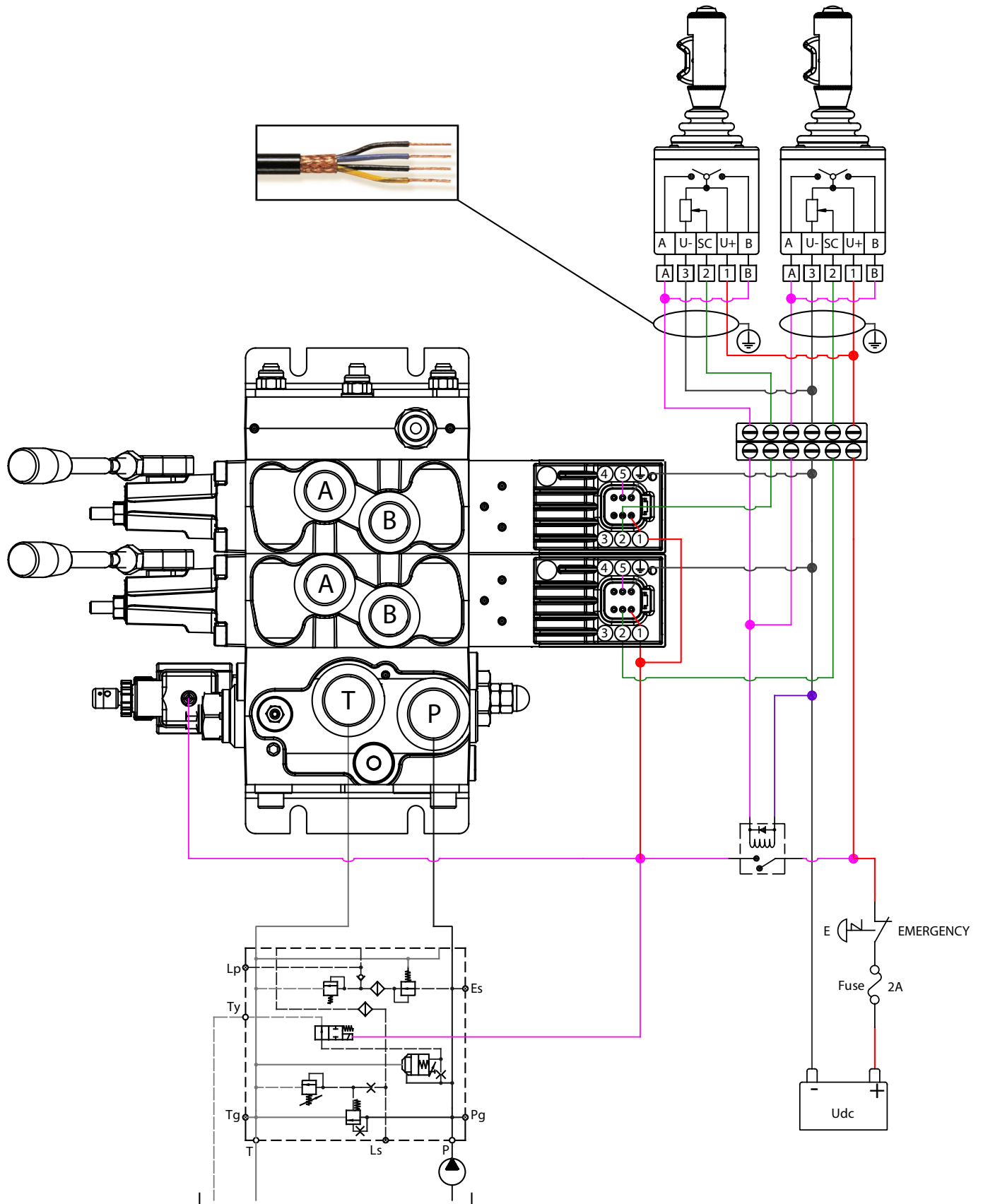

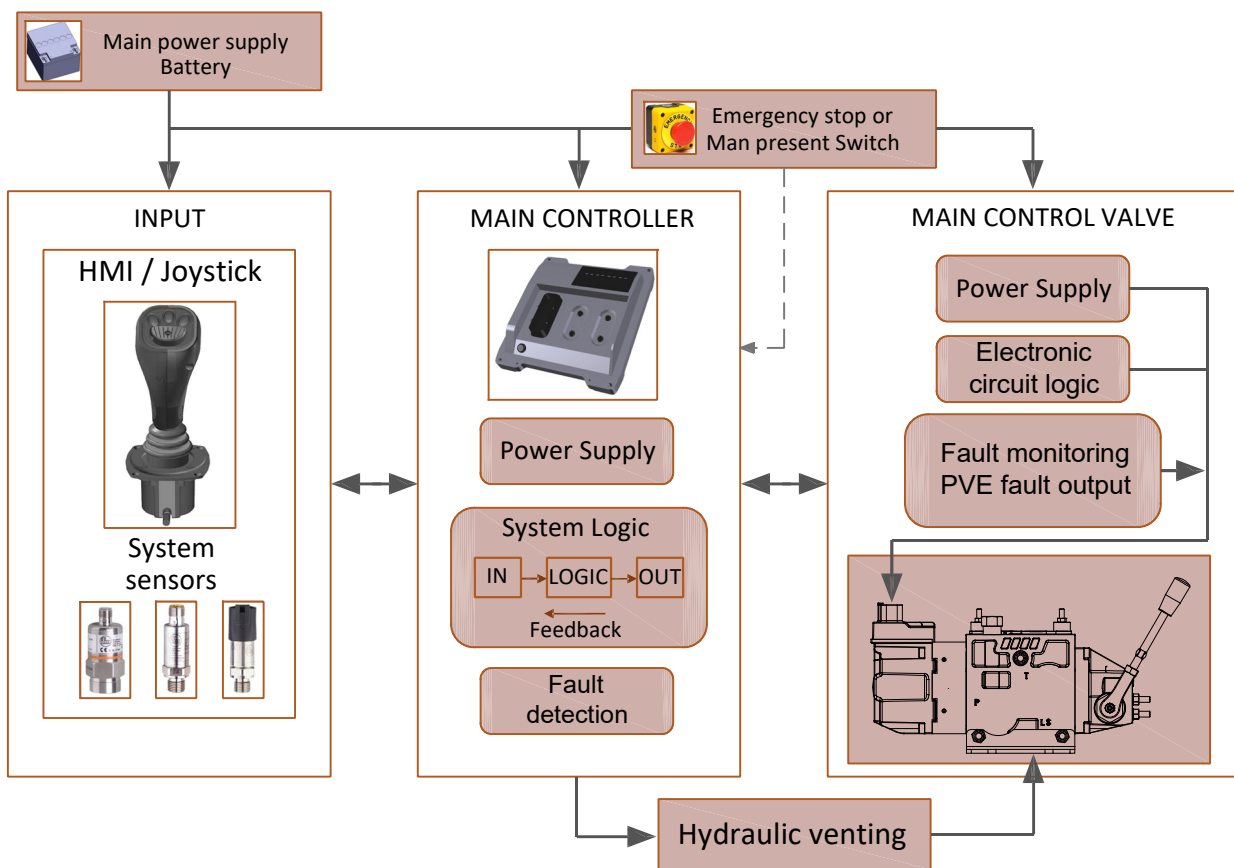

PDV74 - PEAC011 Electro-hydraulic proportional actuation
Electrical wiring diagram with OMFB I/O controller
 Input signal 0,5 Udc

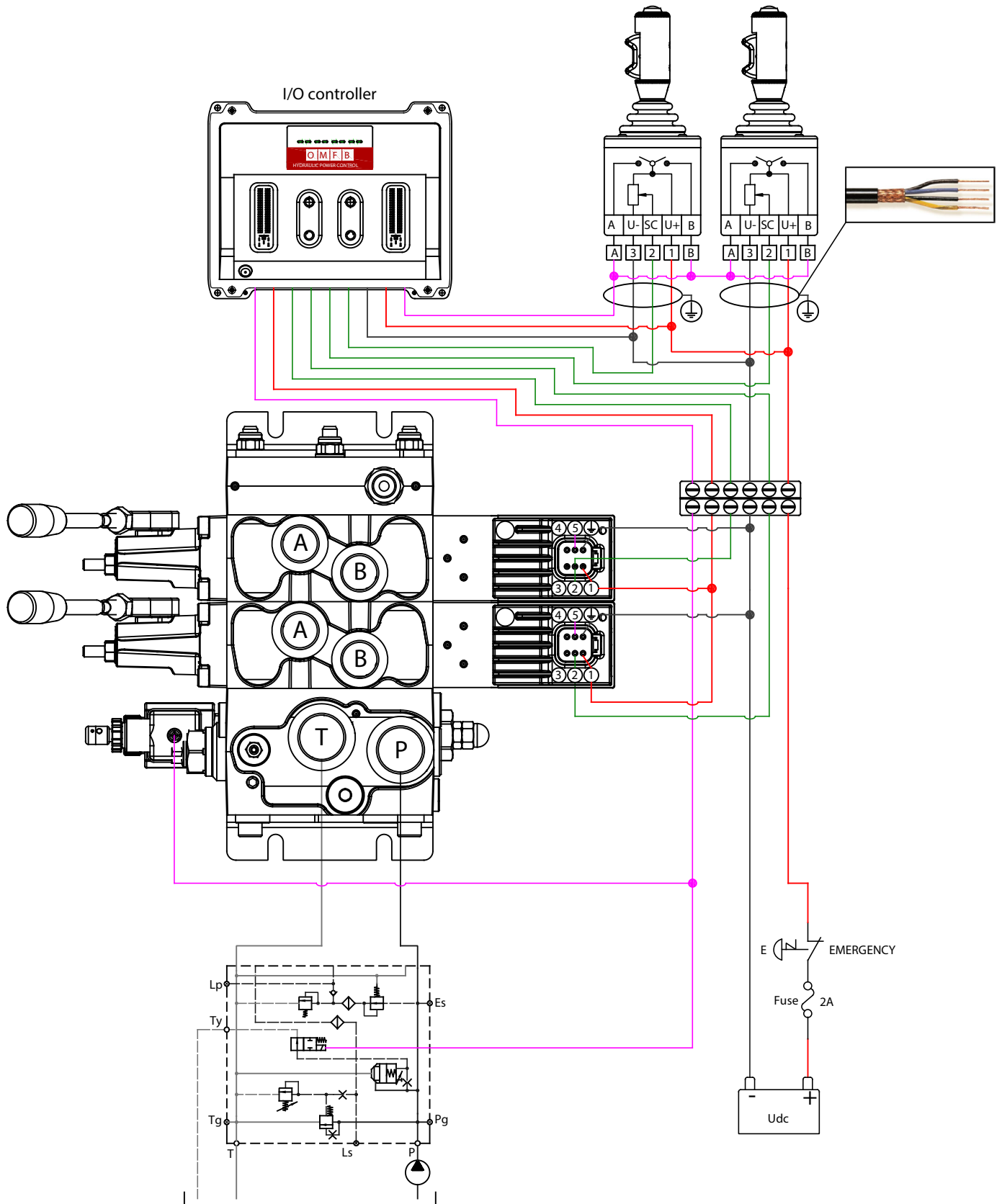

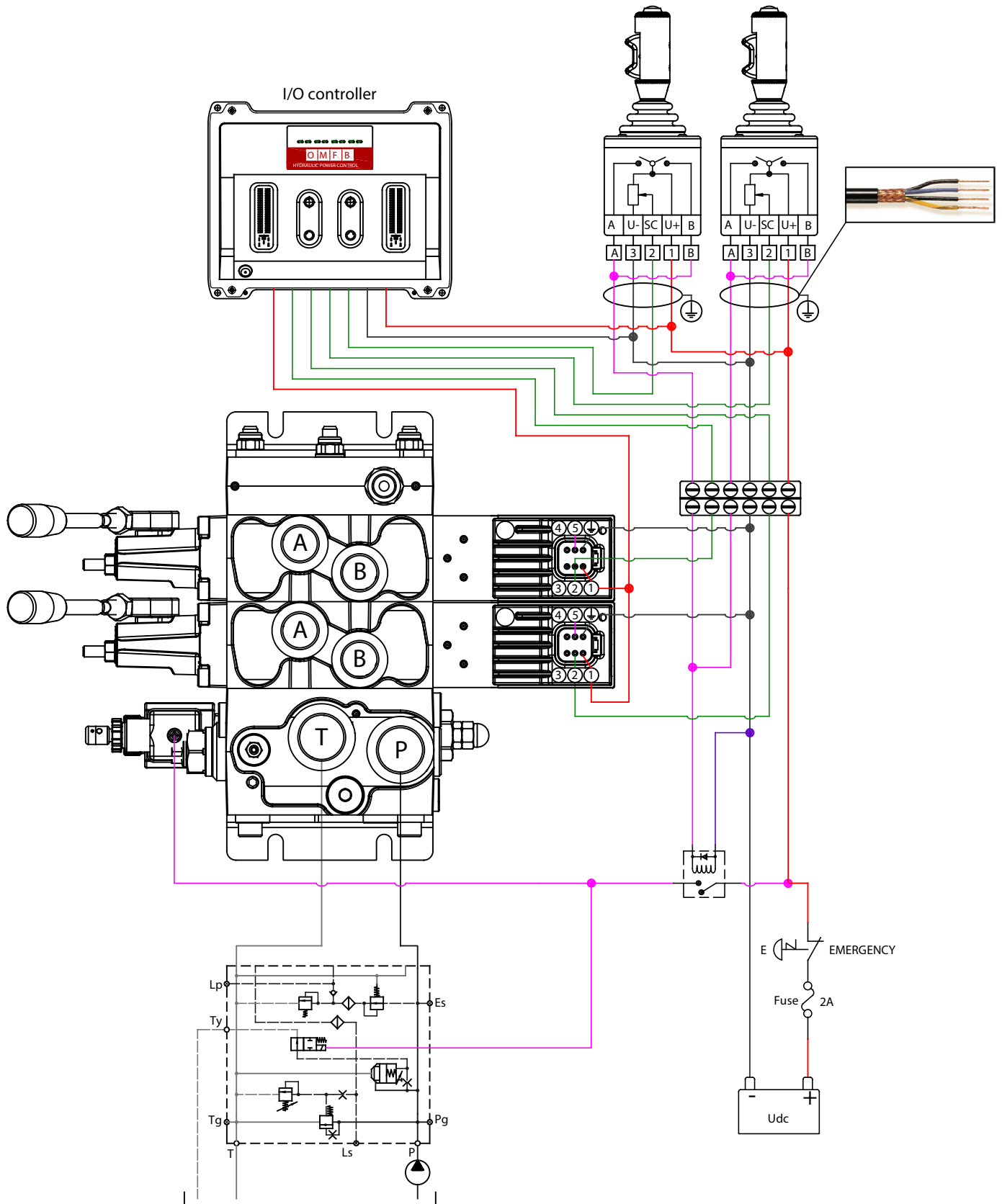

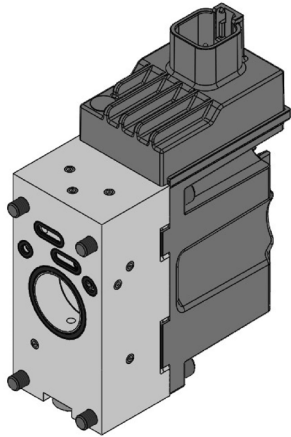

PEAC012 is a proportional open loop spool actuation with integrated electronics that operates the main spool movement according to an electrical signal coming from a remote control.

The input signal by means of the PCB and the two proportional pressure reducing valves, determines the level of the pilot pressure which moves the main spool.

PEAC012 does not have neither the transducer spool position control nor fault monitoring system, this means that any forces which override the pilot pressure spool forces, may change the spool position with no error signal, and the safety of the whole system is left to the operator's visual control, only.

PEAC012 is recommended where a simple proportional control is required, and where hysteresis and reaction time are not so critical.

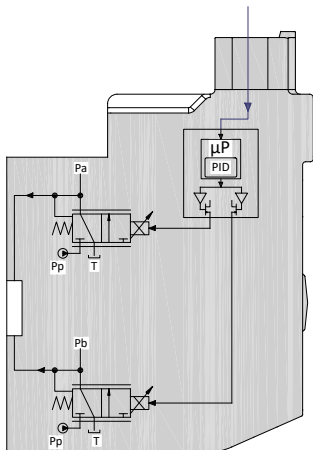

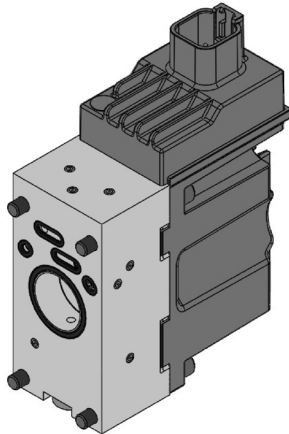

PEAC012 is defined by:

- High spool control accuracy
- EMC performance according to Directive 2014/30/UE
- Quick reaction time
- Integrated PWM/Pulse Width Modulation
- Low electrical power
- Robust and reliable design

PEAC012 Technical data

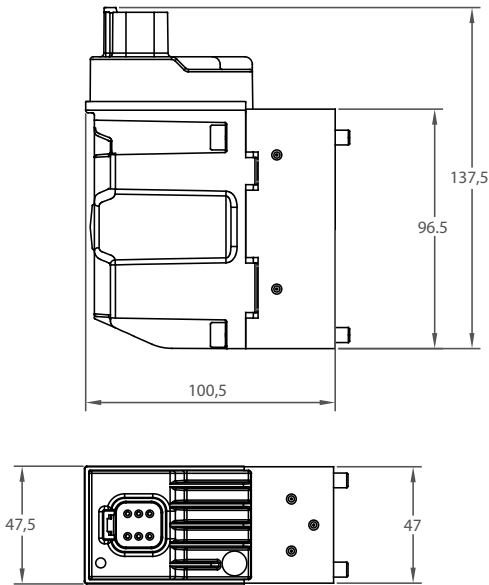
Rated supply voltage	10-30 Vdc	
Max ripple	5%	
Signal control	0-10 V	
Range control signal	2,5 V to 7,5 V	
Neutral spool position	5 V	
Max threshold signal, A port	1 V	
Max threshold signal, B port	1 V	
Max current signal @ rated voltage	48 mA	
Input capacitor	100 nF	
Signal control impedance	25 kΩ	
Power consumption	8,7 W	
Heat insulation	Class H (180°C)	
Duty cycle	ED 100%	
Max current consumption	650 mA	
Current consumption in neutral position	80 mA	
Coil impedance @ 20°C	8,9 Ω	
Dither frequency	50-200 Hz	
Recommended frequency	100 Hz	
Enclosure degree	(Electrical wiring excepted) IP 66 - IP 67 - IP 69K	
Weight cast iron body	1,8 kg	
Weight aluminium body	1,3 kg	
Bootloader function, debugging parameters and set-up function available only with Deutsch connector DT06-6S		
Reaction time (constant voltage)	From neutral position to max spool travel	110 - 140 ms
	From max spool travel to neutral	70 - 90 ms
Reaction time (neutral switch)	From neutral position to max spool travel	130 - 170 ms
	From max spool travel to neutral	70 - 90 ms



Deutsch connector DT06-6S Enclosure degree IP 69K PIN-assignment		
	1	Power supply
	2	Input signal control
	3	CAN-high
	4	CAN-low
	5	Free
	6	Ground

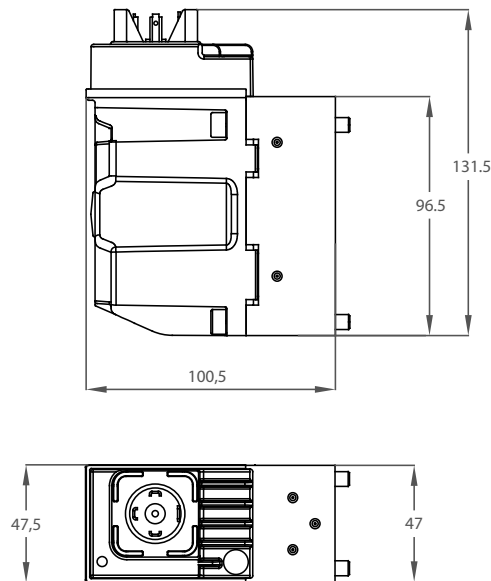

Hirschmann connector DIN 43650 Enclosure degree IP 65 PIN-assignment		
	1	Power supply
	2	Input signal control
	3	Free
	4	Ground

Connector version	Code numbers			
	Active version		Passive version	
	Cast-iron body	Aluminium body	Cast-iron body	Aluminium body
Deutsch DT06-6S	PEAC0022000	PEAC1022000	PEAC0012000	PEAC1012000
DIN 43650	PEAC0022200	PEAC1022200	PEAC0012200	PEAC1012200

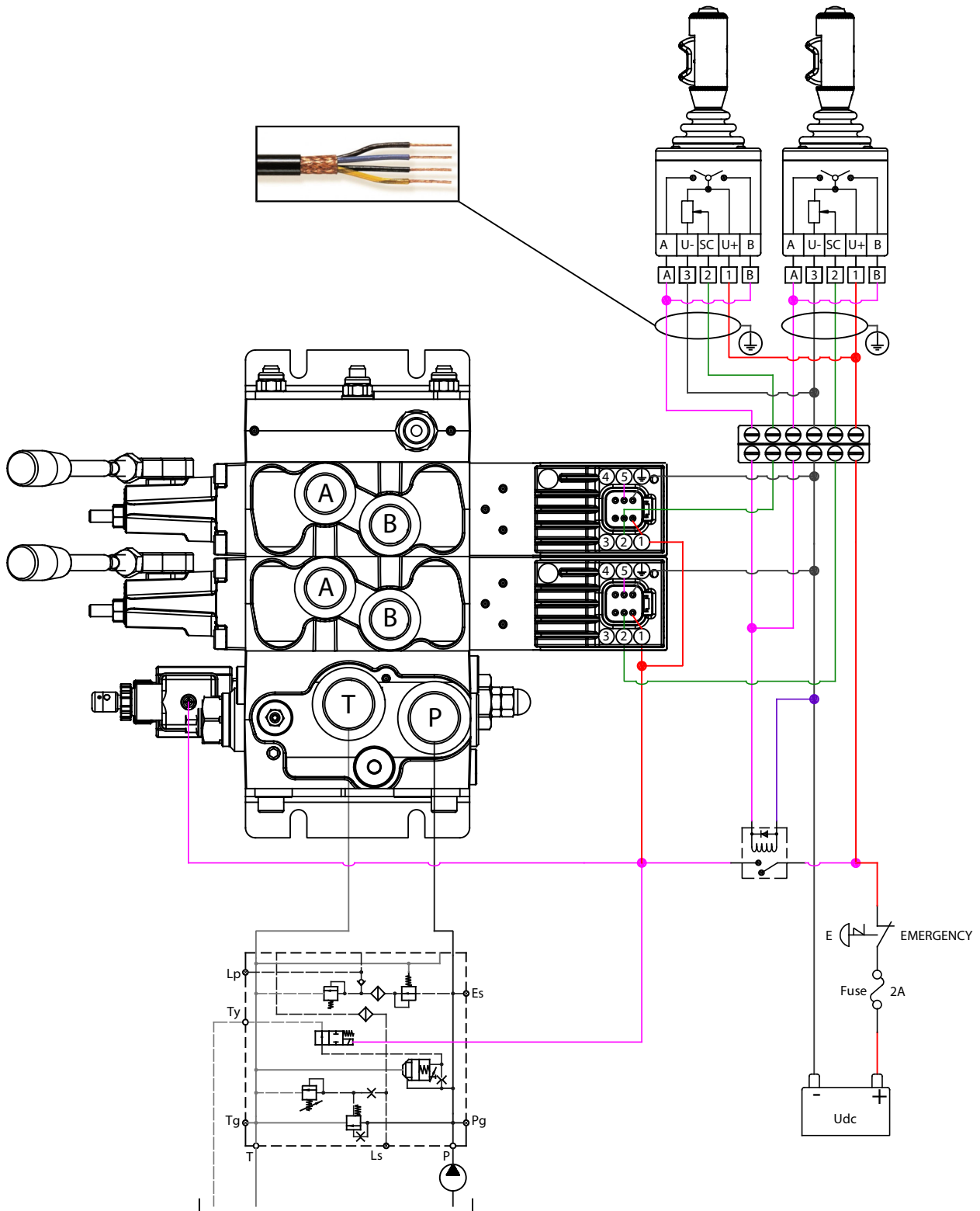

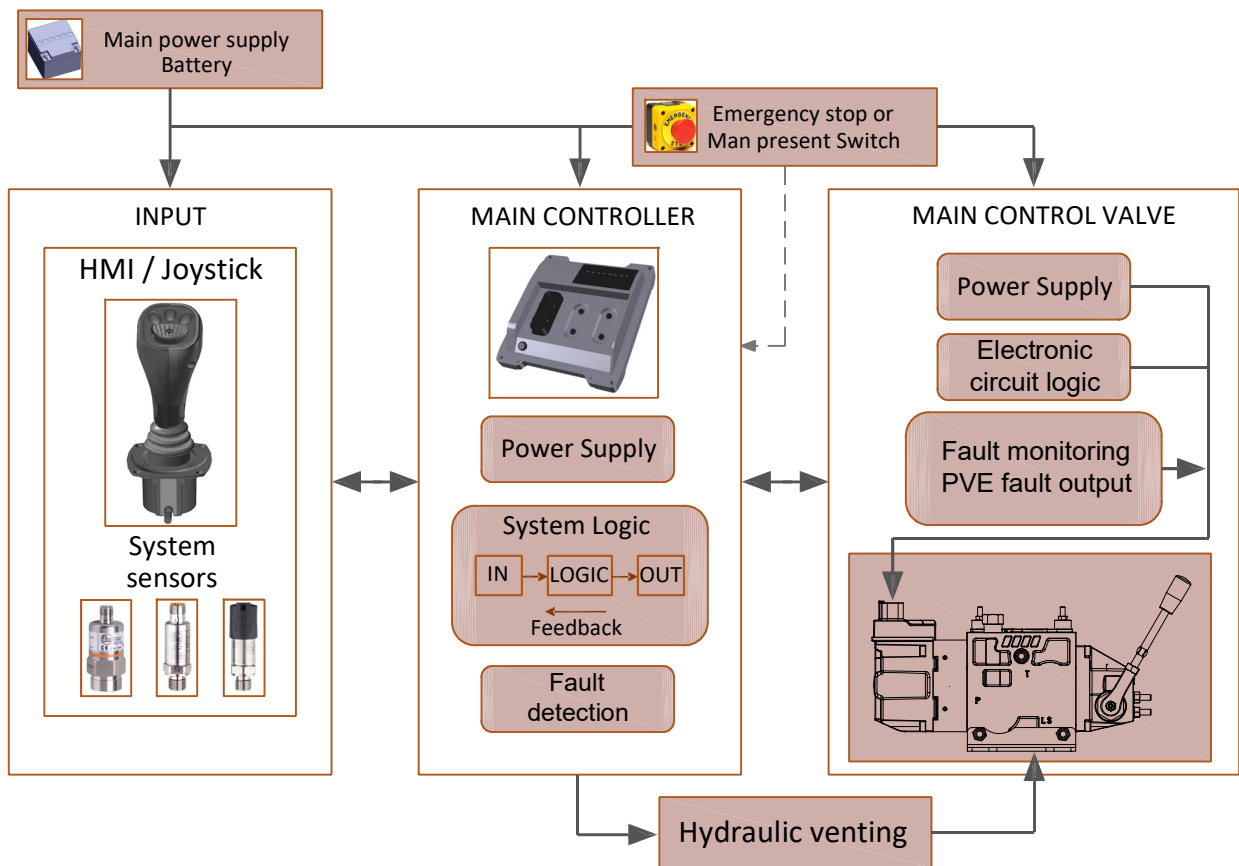

PDV74 - PEAC012 Electro-hydraulic proportional actuation
Electrical wiring diagram with OMFB I/O controller
 Input signal 0 ÷ 10 V

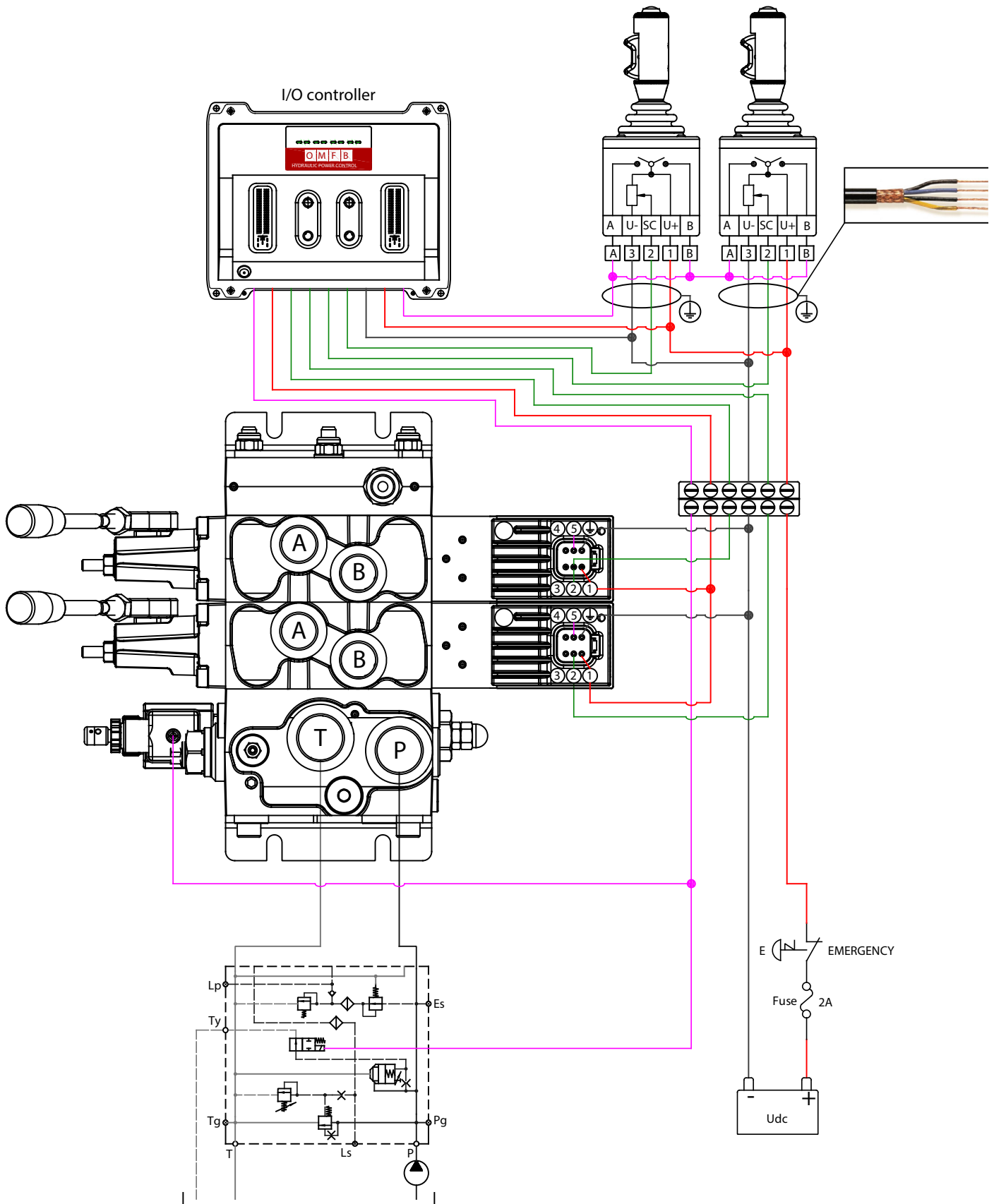

PDV74 - PEAC012 Electro-hydraulic proportional actuation
Electrical wiring diagram with OMFB I/O controller
 Input signal 0 ÷ 10 V

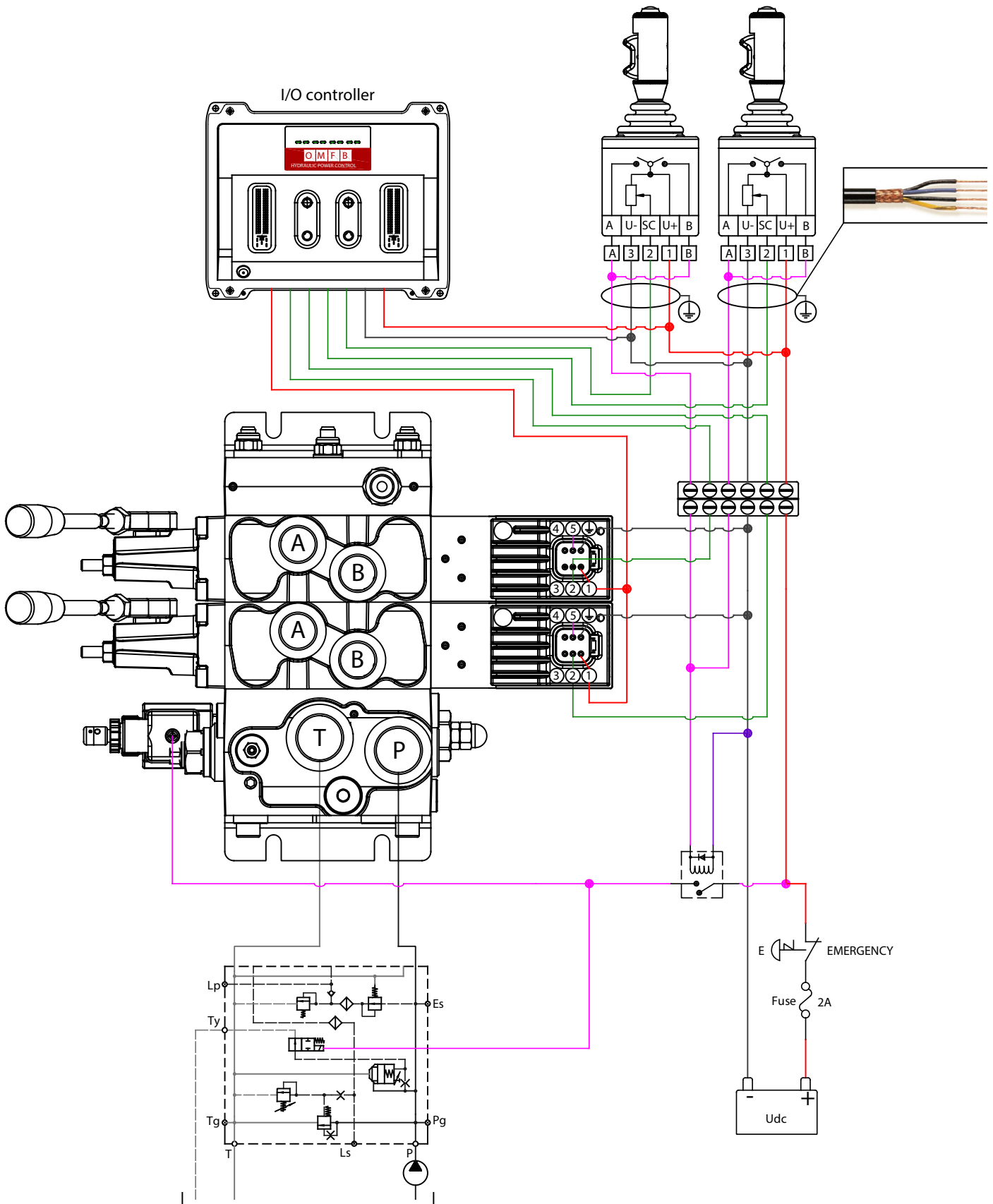

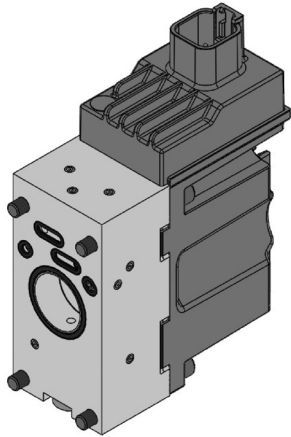

PEAC016 is a proportional open loop spool actuation with integrated electronics that operates the main spool movement according to an electrical signal coming from a remote control.

The input signal by means of the PCB and the two proportional pressure reducing valves, determines the level of the pilot pressure which moves the main spool.

PEAC016 does not have neither the transducer spool position control nor fault monitoring system, this means that any forces which override the pilot pressure spool forces, may change the spool position with no error signal, and the safety of the whole system is left to the operator's visual control, only.

PEAC016 is recommended where a simple proportional control is required, and where hysteresis and reaction time are not so critical.

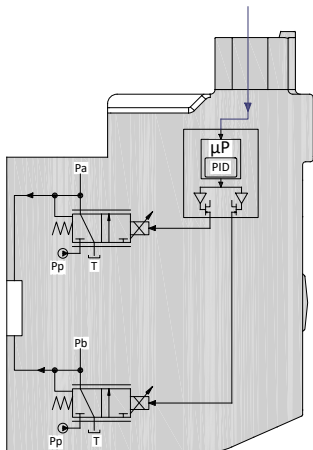

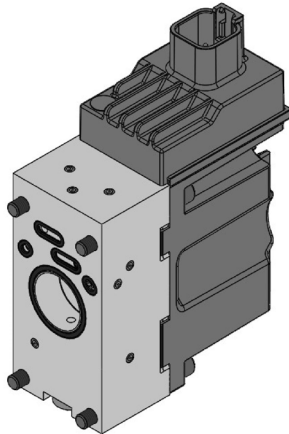

PEAC016 is defined by:

- High spool control accuracy
- EMC performace according to Directive 2014/30/UE
- Quick reaction time
- Integrated PWM/Pulse Width Modulation
- Low electrical power
- Robust and reliable design

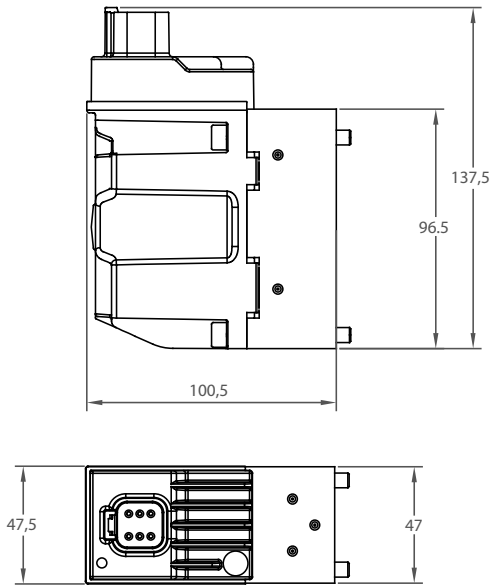
PEAC016 Technical data		
Rated supply voltage		10-30 Vdc
Max ripple		5%
Signal control		4-20 mA
Range control signal		4 mA to 20 mA
Neutral spool position		12 mA
Max threshold signal, A port		1,5 mA
Max threshold signal, B port		1,5 mA
Input capacitor		100 nF
Input impedance		220 Ω
Power consumption		8,7 W
Heat insulation		Class H (180°C)
Duty cycle		ED 100%
Max current consumption		650 mA
Current consumption in neutral position		80 mA
Max current start spool travel		140 mA
Max current end spool travel		450 mA
Coil impedance @ 20°C		8,9 Ω
Signal control impedance		50 KΩ
Dither frequency		50-200 Hz
Recommended frequency		100 Hz
Enclouser degree	(Electrical wiring excepted)	IP65 - IP66 - IP69K
Bootloader function, debugging parameters and set-up function available with Deutsch connector DT06-6S, only		
Reaction time (constant voltage)	From neutral position to max spool travel	110 - 140 ms
	From max spool travel to neutral	70 - 90 ms
Reaction time (neutral switch)	From neutral position to max spool travel	130 - 170 ms
	From max spool travel to neutral	70 - 90 ms

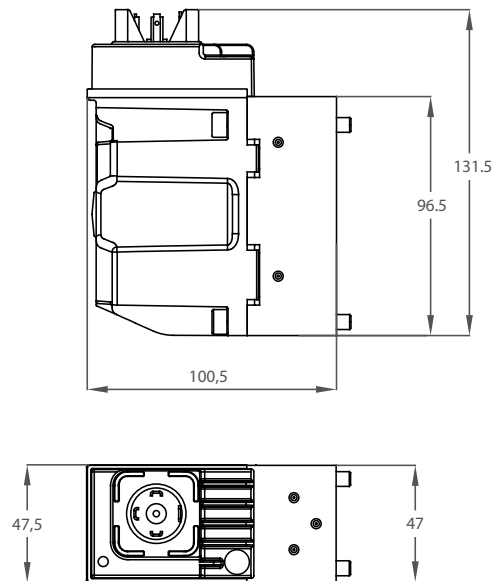

Deutsch connector DT06-6S Enclosure degree IP 69K PIN-assignment		
	1	Power supply
	2	Input signal control
	3	CAN-high
	4	CAN-low
	5	Free
	6	Ground



Hirschmann connector DIN 43650 Enclosure degree IP 65 PIN-assignment		
	1	Power supply
	2	Input signal control
	3	Free
	4	Ground

Connector version	Code numbers			
	Active version		Passive version	
	Cast-iron body	Aluminium body	Cast-iron body	Aluminium body
Deutsch DT06-6S	PEAC0026000	PEAC1026000	PEAC0016000	PEAC1016000
DIN 43650	PEAC0026200	PEAC1026200	PEAC0016200	PEAC1016200

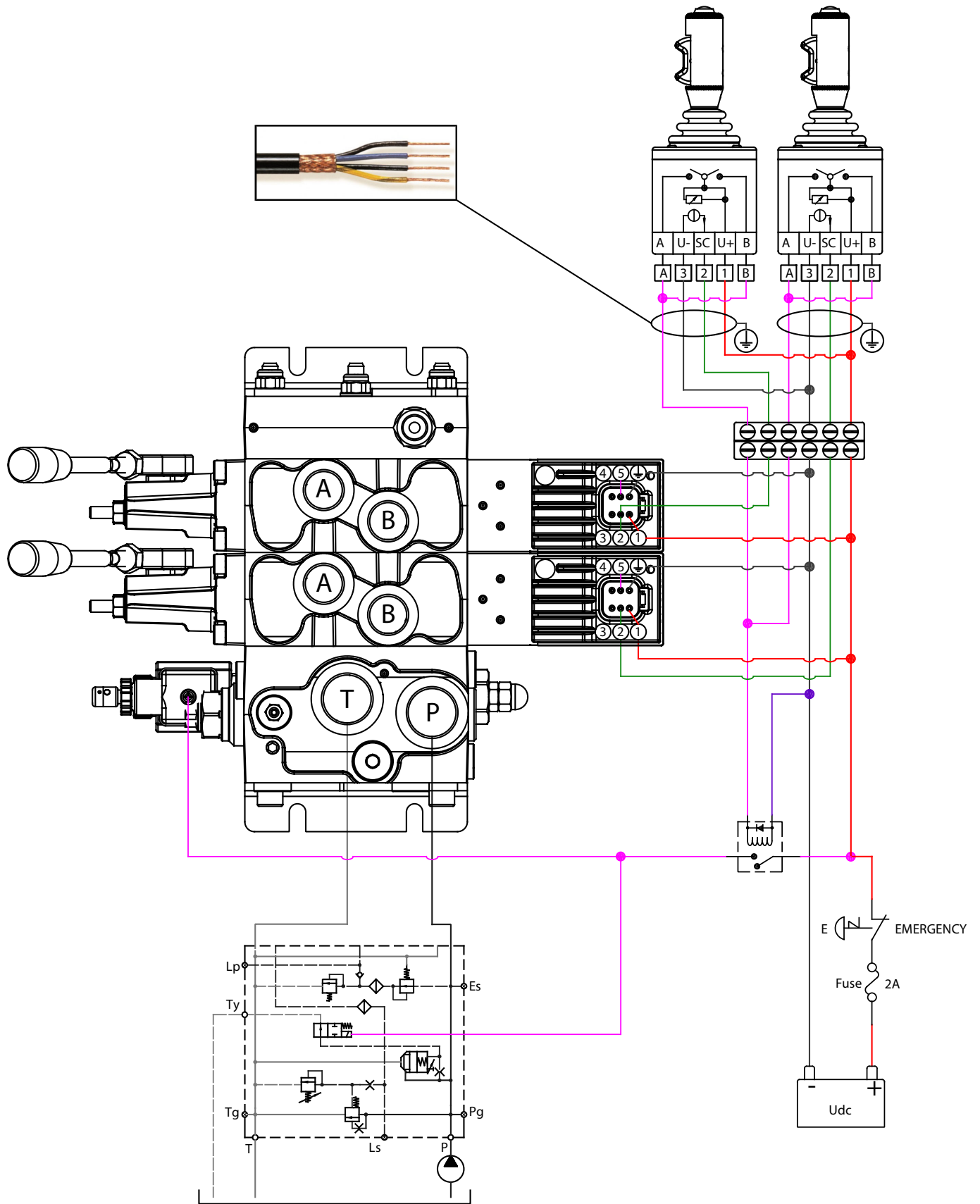

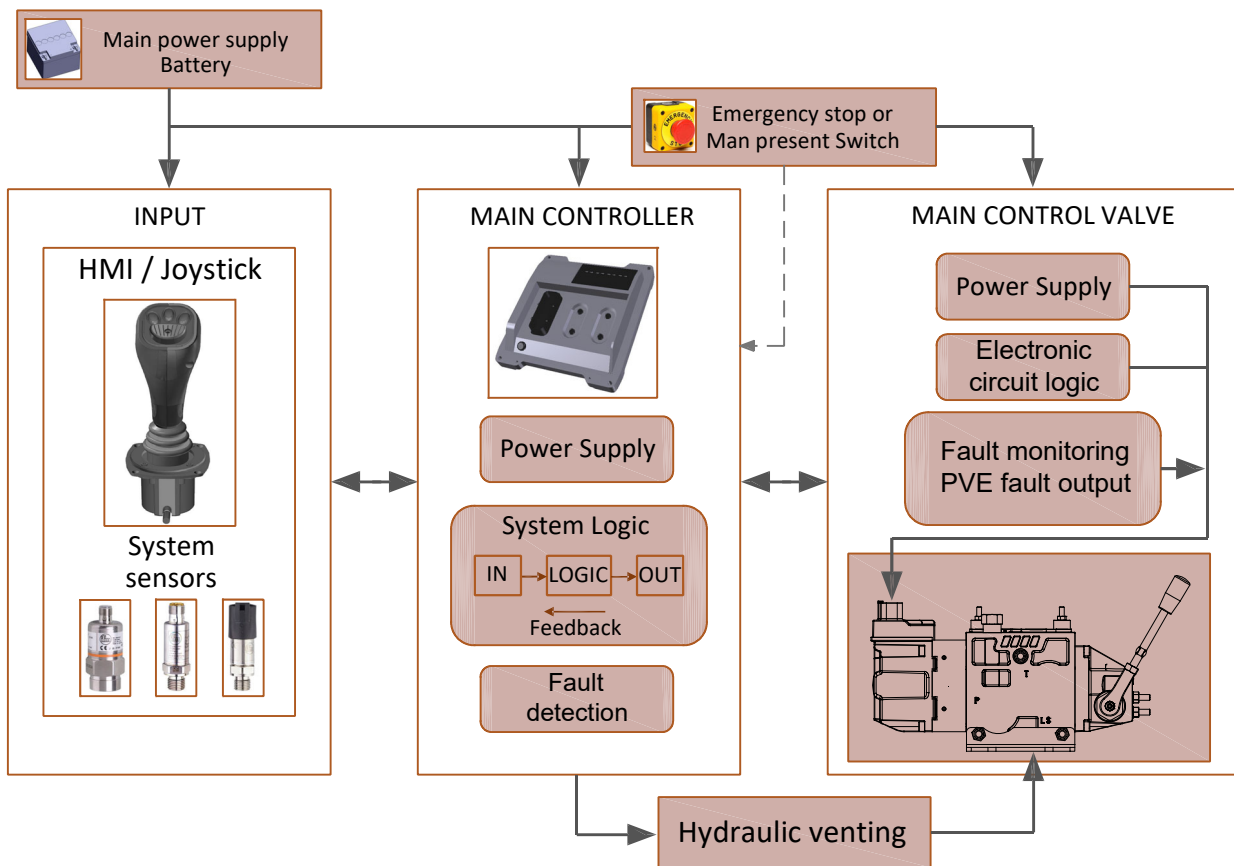

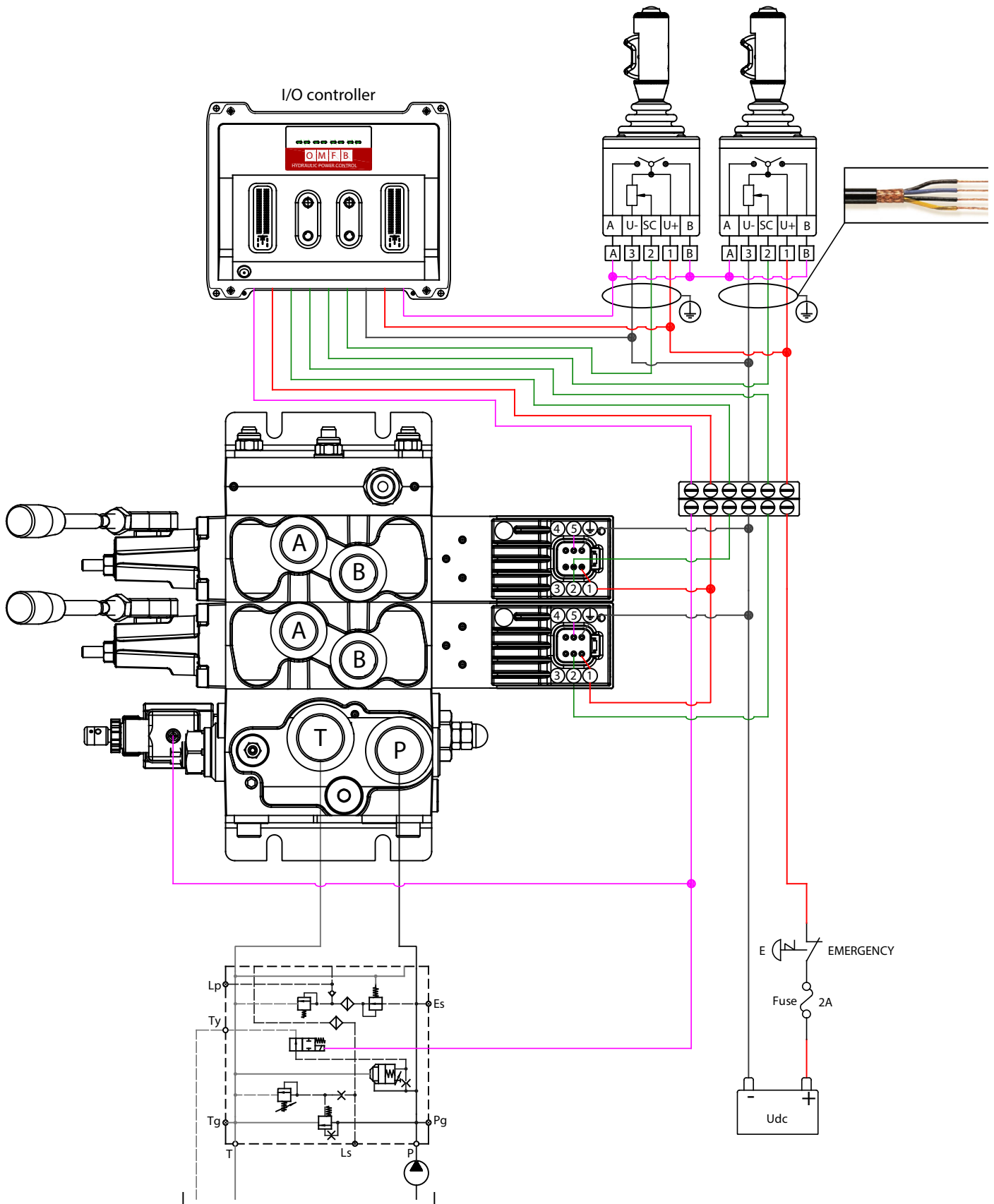

PDV74 - PEAC016 Electro-hydraulic proportional actuation.
Electrical wiring with OMFB I/O controller
Current input signal 4 ÷ 20 mA

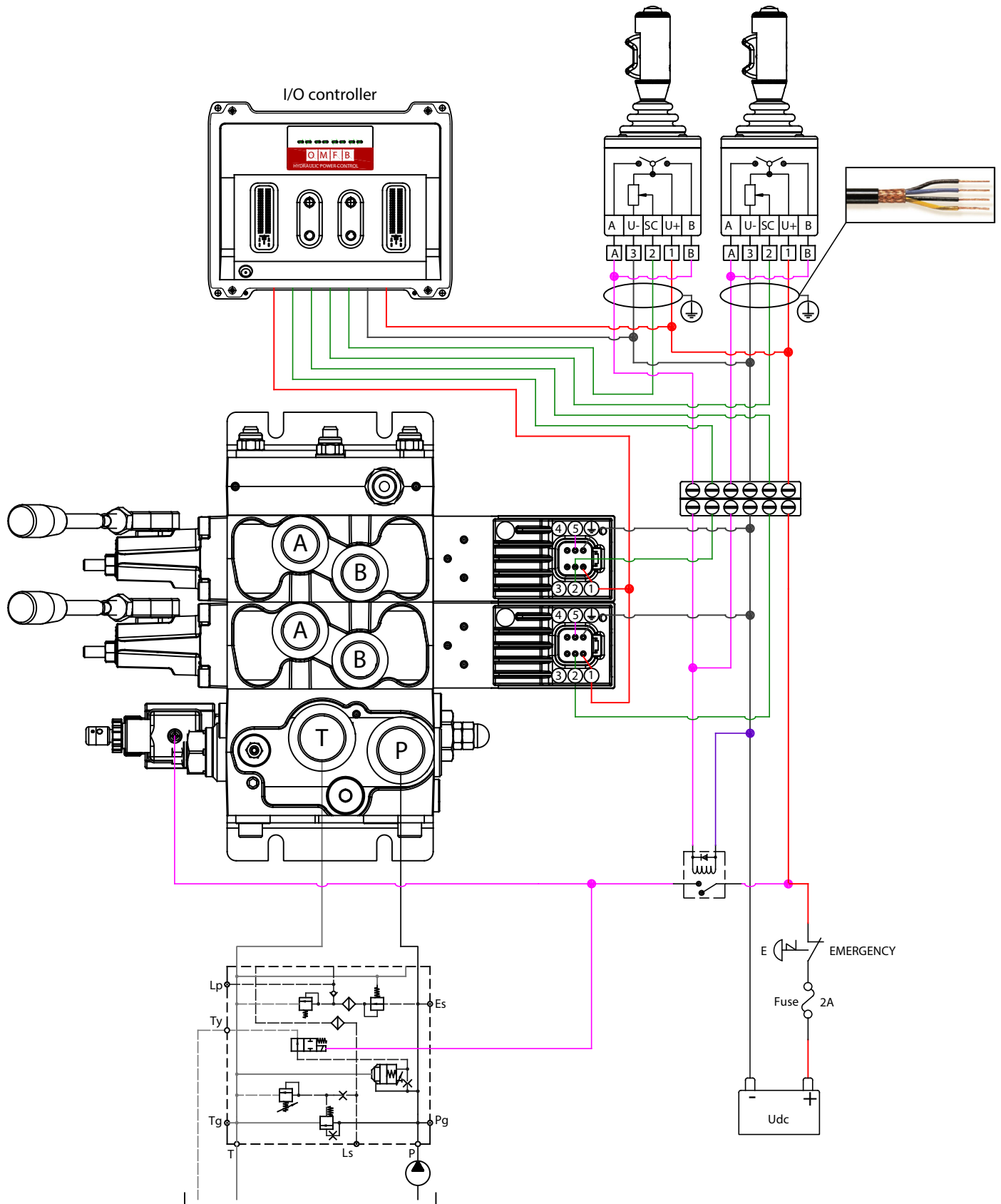

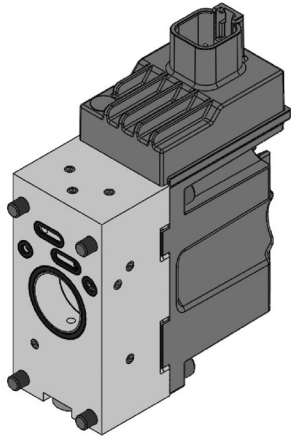

PEAD1 is a proportional open loop spool actuation without integrated electronics that operates the main spool movement according to an electrical signal coming from a remote control.

The input signal by means of the two proportional pressure reducing valves, determines the level of the pilot pressure which moves the main spool.

PEAD1 does not have neither the transducer spool position control nor fault monitoring system, this means that any forces which override the pilot pressure spool forces, may change the spool position with no error signal, and the safety of the whole system is left to the operator's visual control, only.

PEAD1 is recommended where a simple proportional control is required, and where hysteresis and reaction time are not so critical.

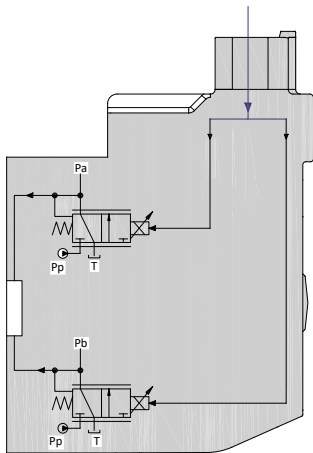

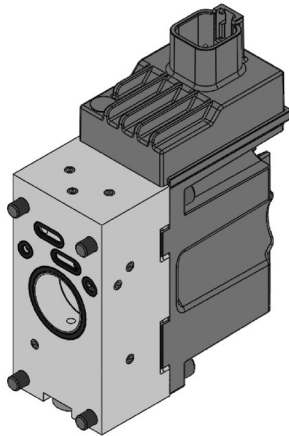

PEAD1 is defined by:

- High spool control accuracy
- EMC performace according to Directive 2014/30/UE
- Quick reaction time
- Integrated PWM/Pulse Width Modulation
- Low electrical power
- Robust and reliable design

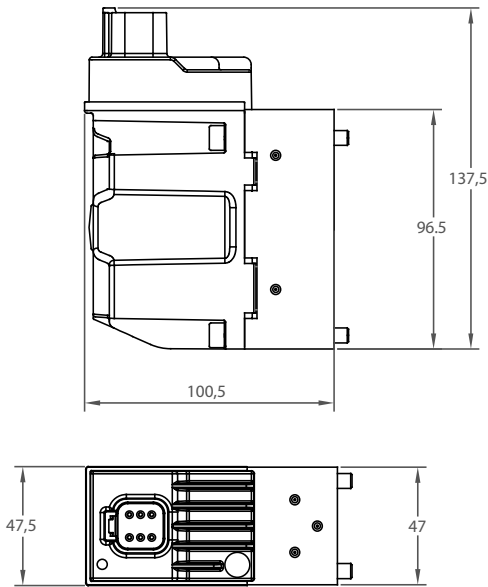
PEAD1 Technical data		
Supply voltage		12 Vdc 24 Vdc
Voltage range		10-16 V 20-30 V
Max ripple		5% 5%
Current consumption at rated voltage		750 mA @ 12 Vdc 400 mA @ 24 Vdc
Power consumption		9 W 9,6 W
R @ 20°C		8,9 Ω 35 Ω
Start spool travel		220 mA 140 mA
End spool travel flow control		650 mA 350 mA
Max spool flow in pre-floating position		650 mA 350 mA
Spool floating position		750 mA 400 mA
Heat insulation		Class H (180°C)
Oil temperature (Recommended)		20 ÷ 60 °C
Oil temperature (Min)		-30 °C
Oil temperature (Max)		80 °C
Ambient temperature		-30 ÷ 60 °C
PWM frequency		50 ÷ 200 Hz
Best frequency		100 Hz
Duty cycle		100% ED
Plug connector		6 pins Deutsch or 4 pins DIN
Enclouser degree	(Electrical wiring excepted)	IP69K
Weight cast iron body		1, 8 kg
Weight Aluminium body		1,3 kg
Max current output signal for spool direction moviment		50 mA
Reaction time (constant voltage)	From neutral position to max spool travel	110 - 140 ms
	From max spool travel to neutral	70 - 90 ms
Reaction time (neutral switch)	From neutral position to max spool travel	130 - 170 ms
	From max spool travel to neutral	70 - 90 ms

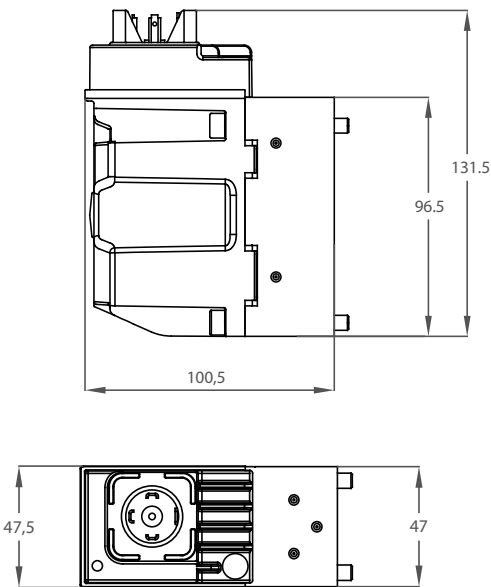

Deutsch connector DT06-6S Enclosure degree IP 69K PIN-assignment		
	1	A port +
	2	Free
	3	A port -
	4	B port +
	5	Free
	6	B port -



Hirschmann connector DIN 43650 Enclosure degree IP 65 PIN-assignment		
	1	A port +
	2	B port +
	3	Free
	4	Ground

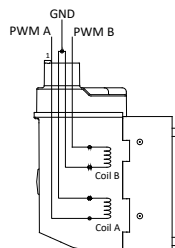

Connector version	Code numbers			
	12 V		24 V	
	Cast-iron body	Aluminium body	Cast-iron body	Aluminium body
Deutsch DT06-6S	PEAD0100000	PEAD1100000	PEAD0200000	PEAD1200000
DIN 43650	PEAD0120000	PEAD1120000	PEAD0220000	PEAD1220000

PDV74 - PEAD1 Electro-hydraulic proportional actuation.
Electrical wiring with OMFB I/O controller - Current input signal for PWM or supply voltage for ON/OFF control

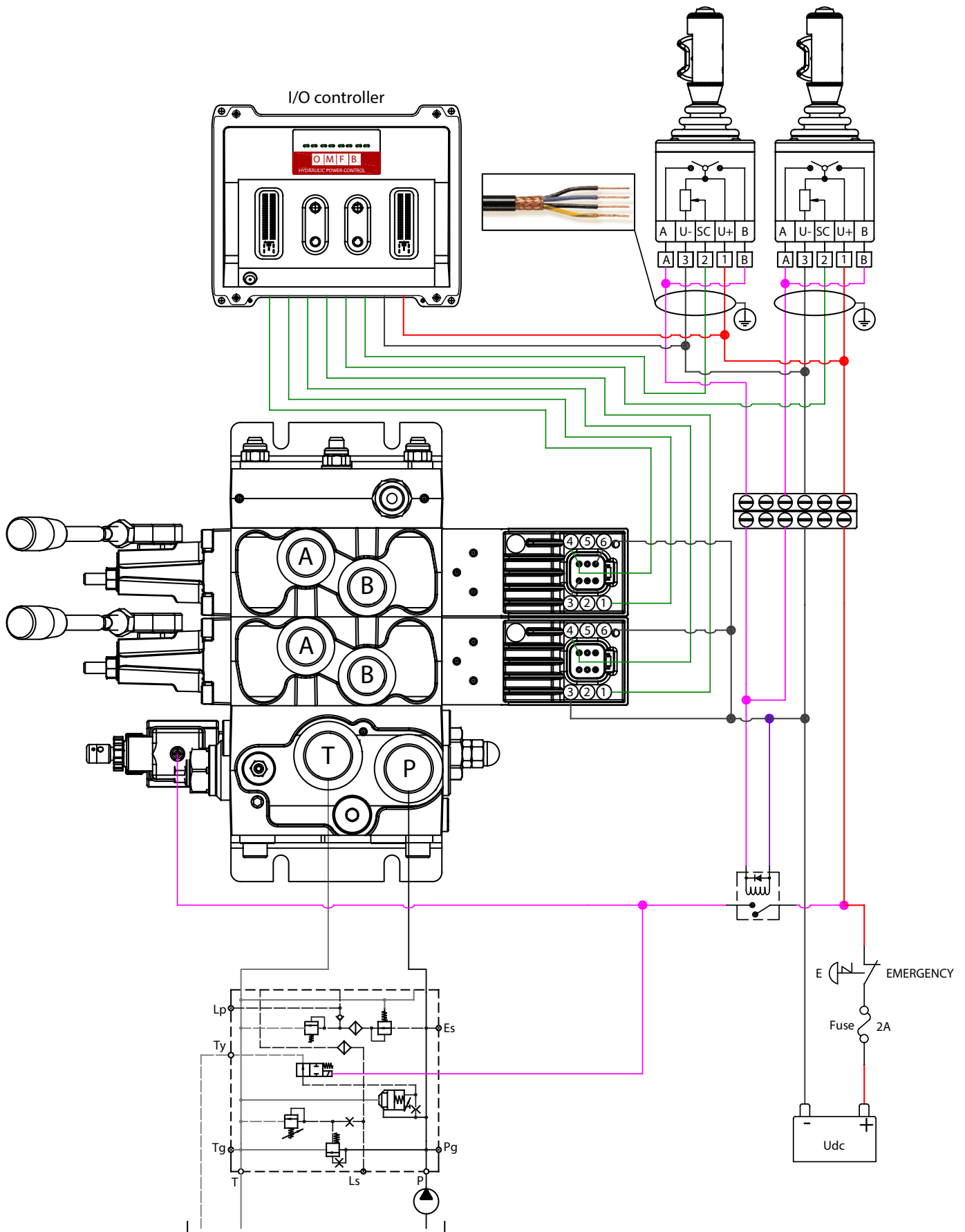

PDV74 - PEAD1 Electro-hydraulic proportional actuation.
Electrical wiring with OMFB I/O controller - Current input signal for PWM or supply voltage for ON/OFF control

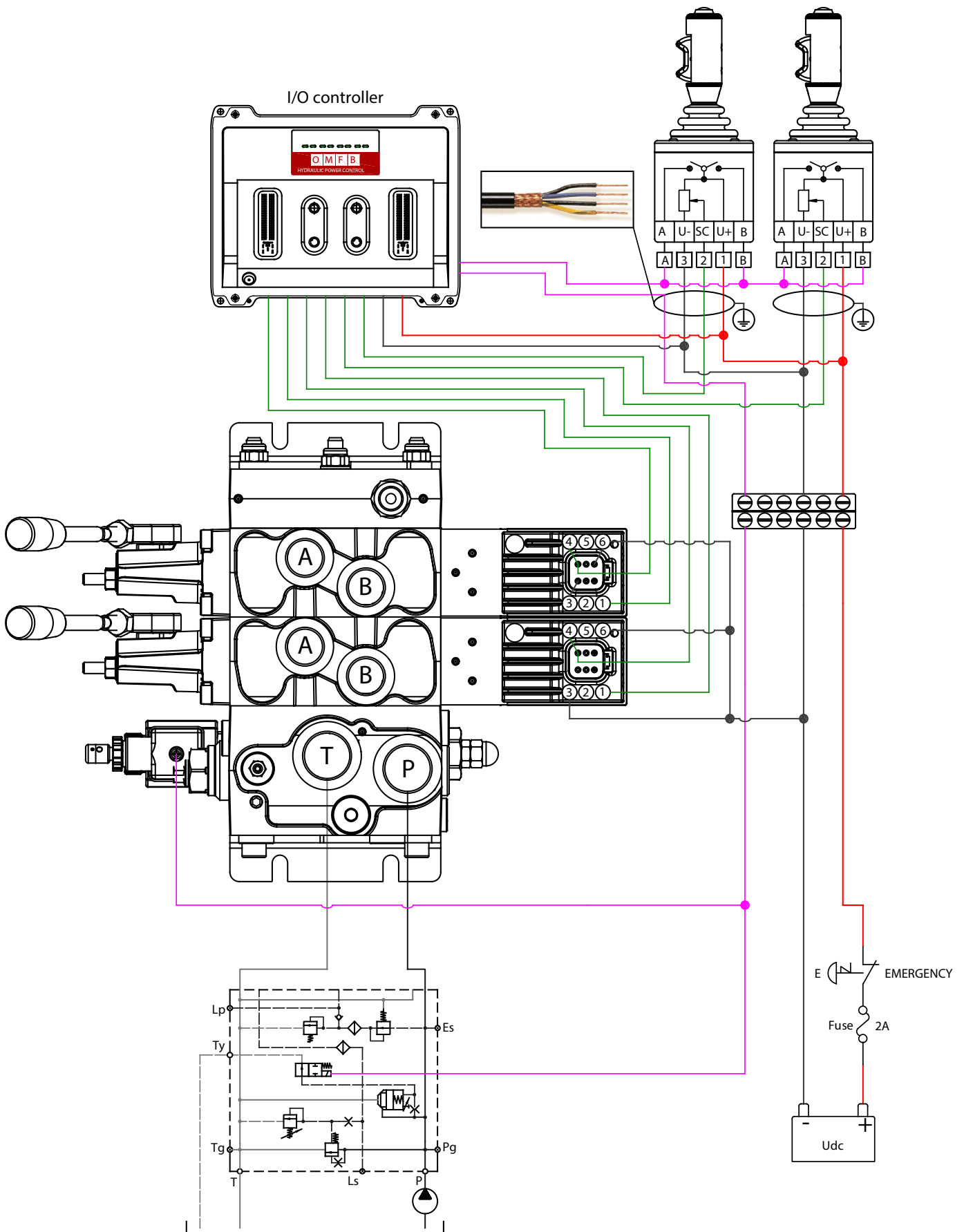

PDV74 - PEAD1 Electro-hydraulic proportional actuation.
Electrical wiring with OMFB I/O controller - Current input signal for PWM or supply voltage for ON/OFF control

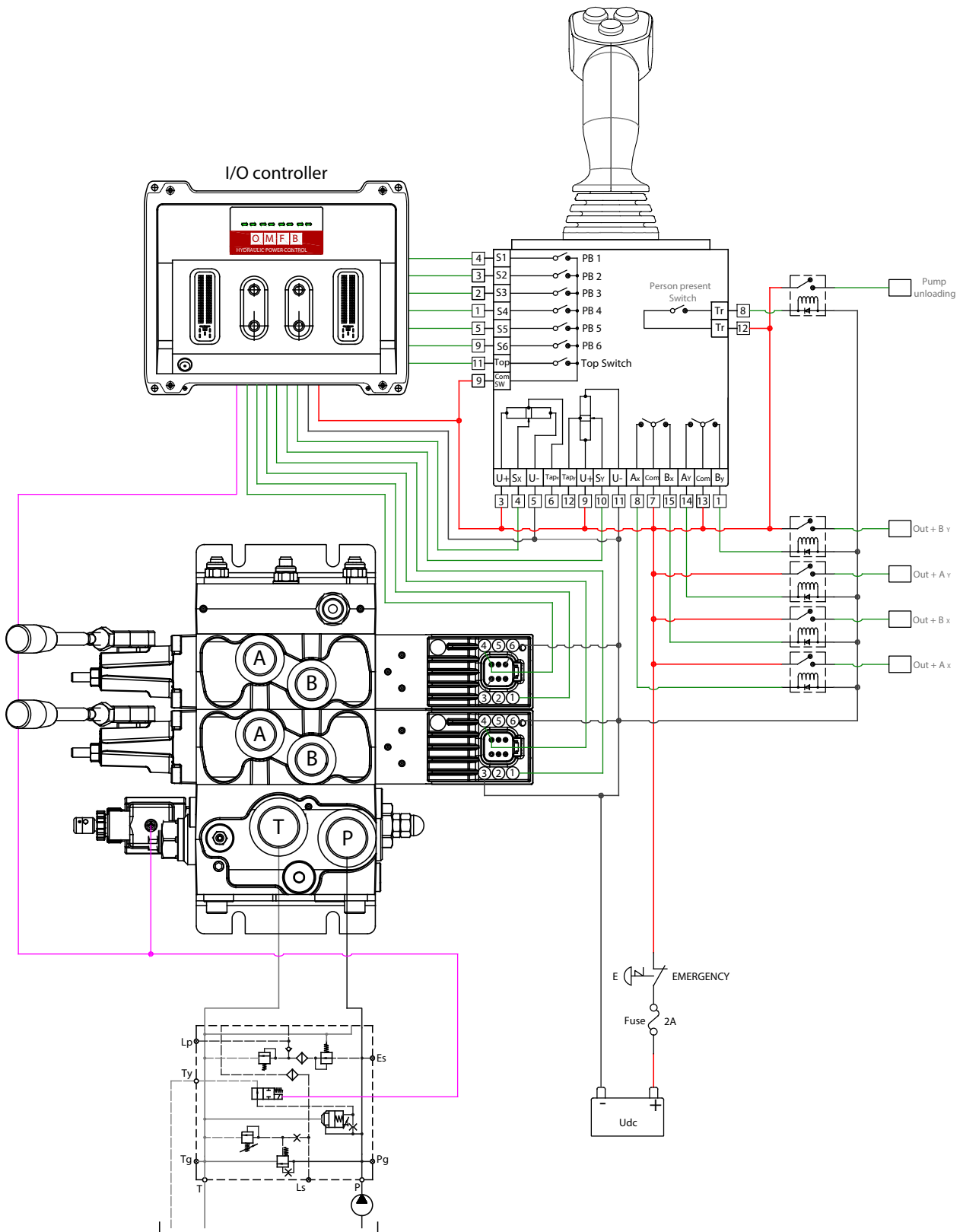

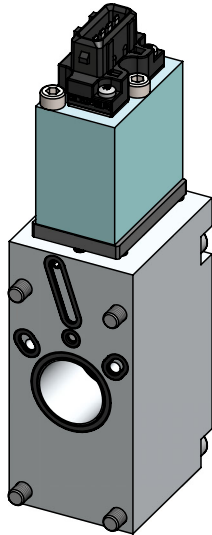

PEAP1 is a proportional open loop spool actuation without integrated electronics that operates the main spool movement according to an electrical signal coming from a remote control.

The input signal by means of the two proportional pressure reducing valves, determines the level of the pilot pressure which moves the main spool.

PEAP1 does not have neither the transducer spool position control nor fault monitoring system, this means that any forces which override the pilot pressure spool forces, may change the spool position with no error signal, and the safety of the whole system is left to the operator's visual control, only.

PEAP1 is recommended where a simple proportional control is required, and where hysteresis and reaction time are not so critical.

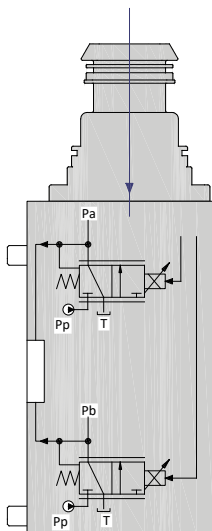

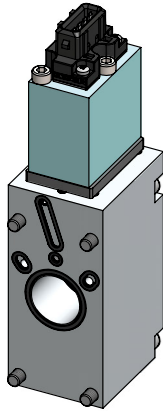

PEAP1 is defined by:

- High spool control accuracy
- EMC performance according to Directive 2014/30/UE
- Quick reaction time
- Integrated PWM/Pulse Width Modulation
- Low electrical power
- Robust and reliable design

PEAP1 Technical data

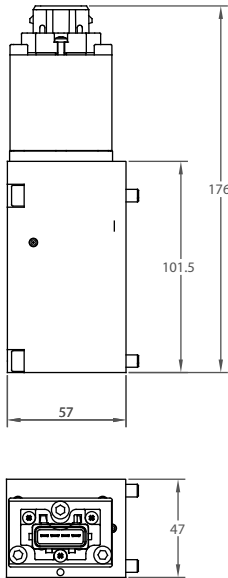
Supply voltage	12 Vdc	24 Vdc
Voltage range	10-16 V	20-30 V
Max ripple	5%	5%
Current consumption at rated voltage	1330 mA @ 12 Vdc	630 mA @ 24 Vdc
Power consumption	23 W	21 W
R @ 20°C	6,3 Ω	27 Ω
Start spool travel	220 mA	140 mA
End spool travel flow control	1330 mA	550 mA
Max spool flow in pre-floating position	1330 mA	630 mA
Spool floating position	750 mA	400 mA
Heat insulation	Class H (180°C)	
Oil temperature (Recommended)	-20 ÷ 60 °C	
Oil temperature (Min)	-30 °C	
Oil temperature (Max)	80 °C	
Ambient temperature	-30 ÷ 60 °C	
PWM frequency	50 ÷ 200 Hz	
Best frequency	100 Hz	
Duty cycle	100% ED	
Plug connector	Amp Junior Power Timer 4 pins	
Enclouser degree	(Electrical wiring excepted) IP69K	
Max current output signal for spool direction movement	50 mA	
Reaction time (constant voltage)	From neutral position to max spool travel	110 - 140 ms
	From max spool travel to neutral	70 - 90 ms
Reaction time (neutral switch)	From neutral position to max spool travel	130 - 170 ms
	From max spool travel to neutral	70 - 90 ms

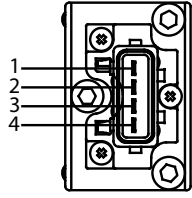

Amp Junior Power Timer 4 pin connector Enclosure degree IP 65 PIN-assignment	
	1 A port +
	2 A port -
	3 B port -
	4 B port +

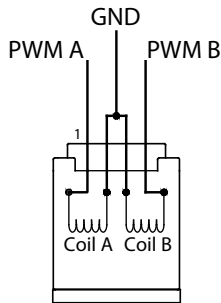

Connector version	Code numbers			
	12 V		24 V	
	Cast-iron body	Aluminium body	Cast-iron body	Aluminium body
AMP Junior timer 4 Pin	PEAP0312000	PEAP1312000	PEAP0412000	PEAP1412000

PDV74 - PEAP1 Electro-hydraulic proportional actuation
Electrical wiring with OMFB I/O controller - Current input signal for PWM or supply voltage for ON/OFF control

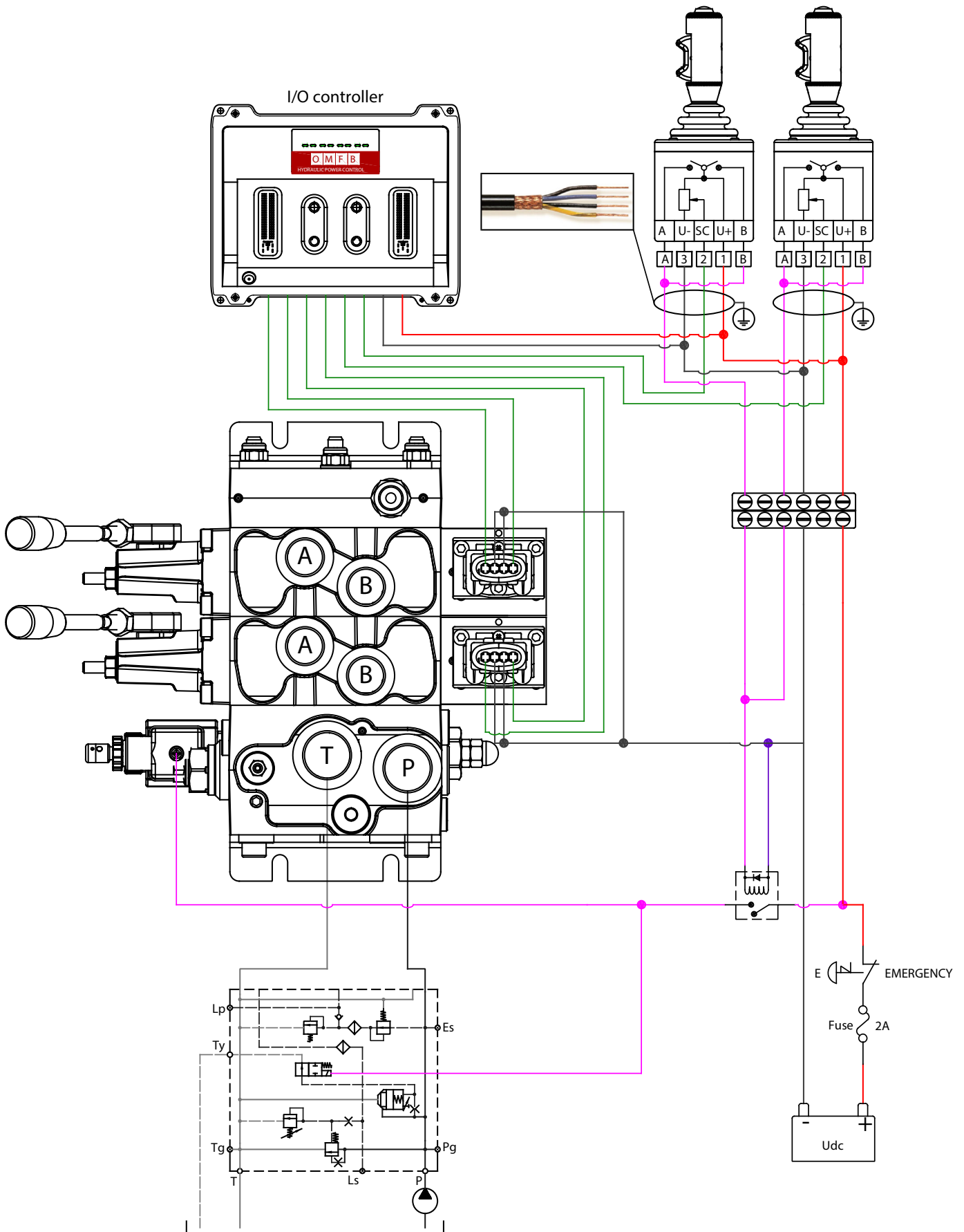

PDV74 - PEAP1 Electro-hydraulic proportional actuation
Electrical wiring with OMFB I/O controller - Current input signal for PWM or supply voltage for ON/OFF control

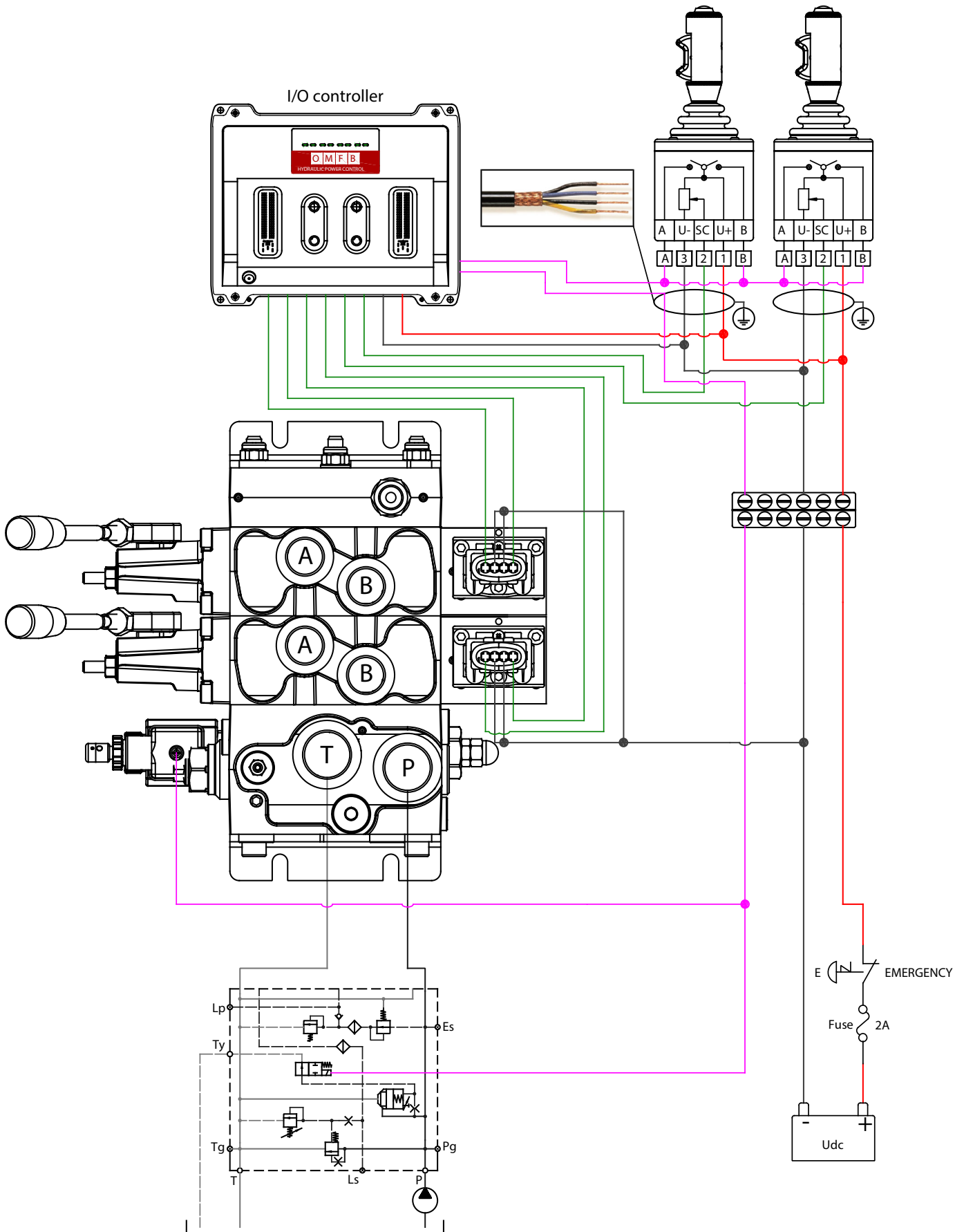

PDV74 - PEAP1 Electro-hydraulic proportional actuation
Electrical wiring with OMFB I/O controller - Current input signal for PWM or supply voltage for ON/OFF control

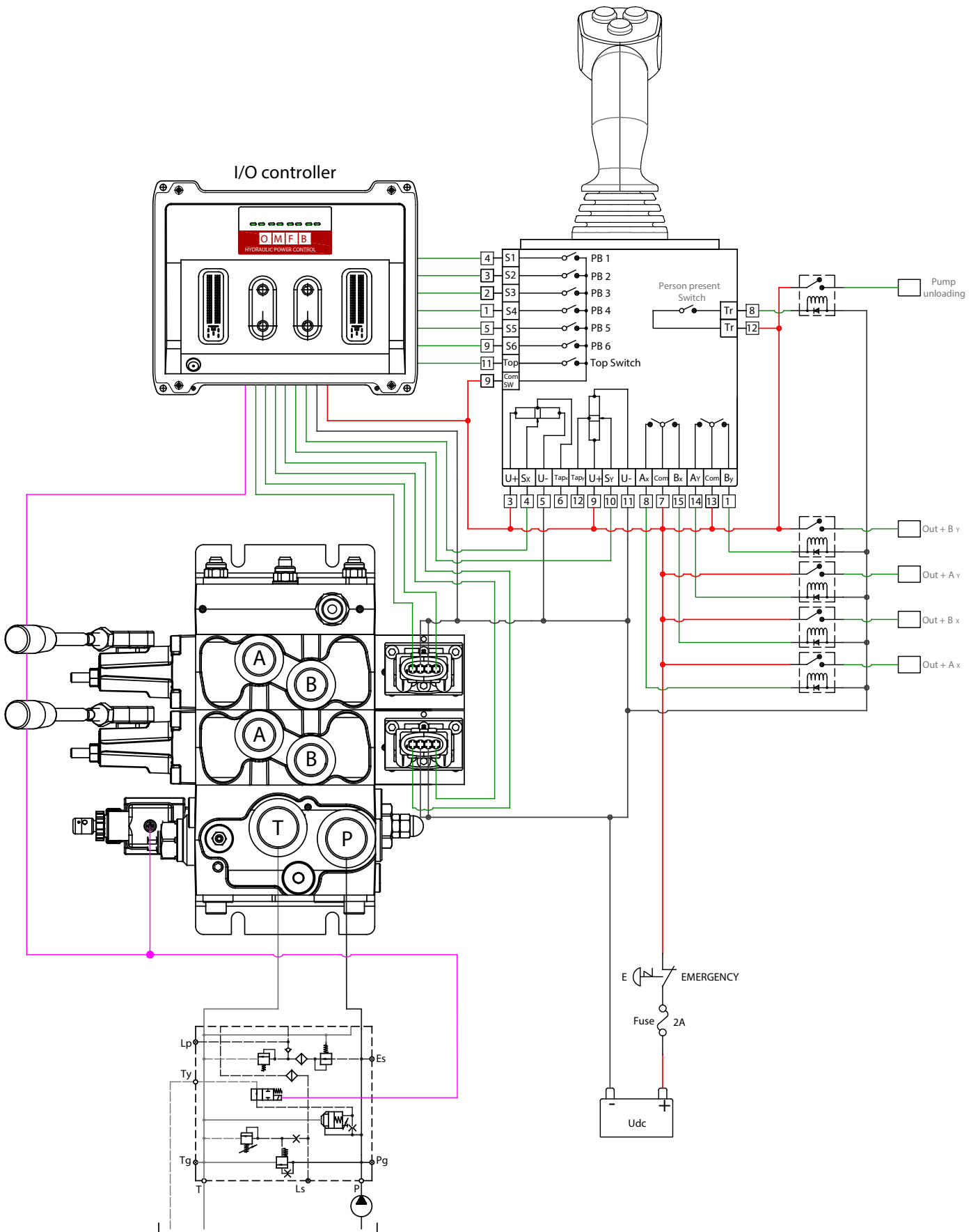

PDV74 Proportional valve

Overall dimensions drawing with standard inlet section

Right assembly version

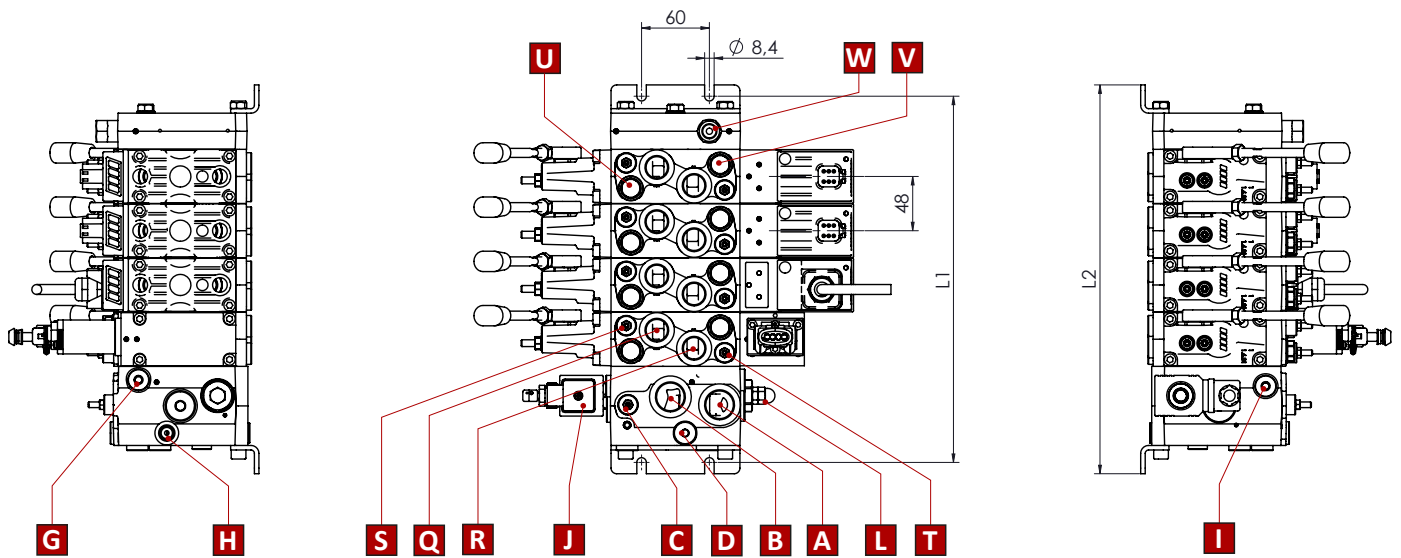
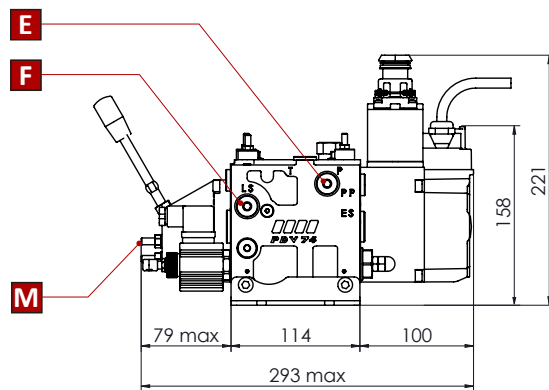
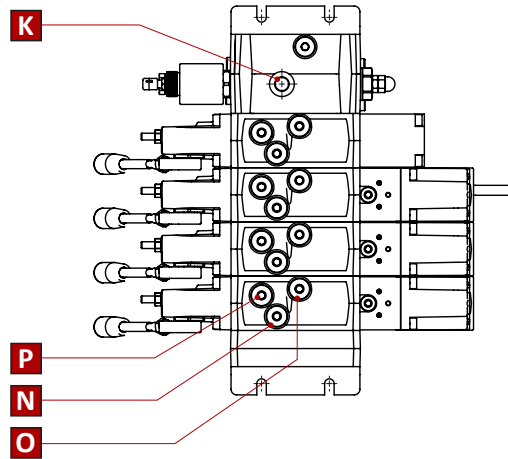

PDW		1	2	3	4	5	6	7	8	9	10	11	12
L1	mm	180	228	276	324	372	420	468	516	564	612	660	708
	in	7,09	8,98	10,87	12,76	14,65	16,54	18,43	20,31	22,20	24,09	25,98	27,87
L2	mm	200	248	296	344	392	440	488	536	584	632	680	728
	in	7,87	9,76	11,65	13,54	15,43	17,32	19,21	21,10	22,99	24,88	26,77	28,66

- A** = Pump side port - 3/4" BSPP - 17 mm deep [1 1/16 in 12 UN-2B - 0,67 in deep]
B = T port - 3/4" BSPP - 17 mm deep [1 1/16 in 12 UN - 2B - 0,67 in deep]
C = Main pressure relief valve
D = Main pressure reducing valve
E = Pump pressure gauge connection - 1/4" BSPP - 12 mm deep [7/16 in-20 UNF-2B - 0,47 in deep]
F = LS connection 1/4" BSPP - 12 mm deep [7/16 in-20 UNF-2B - 0,47 in deep]
G = External pilot pressure supply connection 1/4" BSPP - 12 mm deep [7/16 in-20 UNF-2B - 0,47 in deep]
H = External feeding main pressure reducing valve 1/4" BSPP - 12 mm deep [7/16 in-20 UNF-2B - 0,47 in deep]
I = Tank pressure gauge connection 1/4" BSPP - 12 mm deep [7/16 in-20 UNF-2B - 0,47 in deep]
J = Electrical LS/pump unloading function
K = Pump unloading drain port, 1/4" BSPP - 12 mm deep [7/16 in-20 UNF - 2B - 0,47 in deep]
L = Pump unloading mechanical override
M = A-B port mechanical flow adjustment
N = LSA
O = LSB } remote pilot pressure connection 1/4" BSPP - 12 mm deep [7/16 in-20 UNF - 2B - 0,47 in deep]
P = LS }
Q = Port A } 1/2" BSPP - 17 mm deep [7/8 in-14 UNF-2B - 0,67 in deep]
R = Port B }
S = LSB } pilot pressure relief valve
T = LSA }
U = Shock/suction valve B port
V = Shock/suction valve A port
W = External drain connection electric actuations - 1/4" BSPP - 12 mm deep [7/16 in-20 UNF-2B - 0,47 in deep]

PDV74 with open centre inlet section (fixed displacement pump),
pump unloading system, pilot oil supply for electro-hydraulic
spool actuations

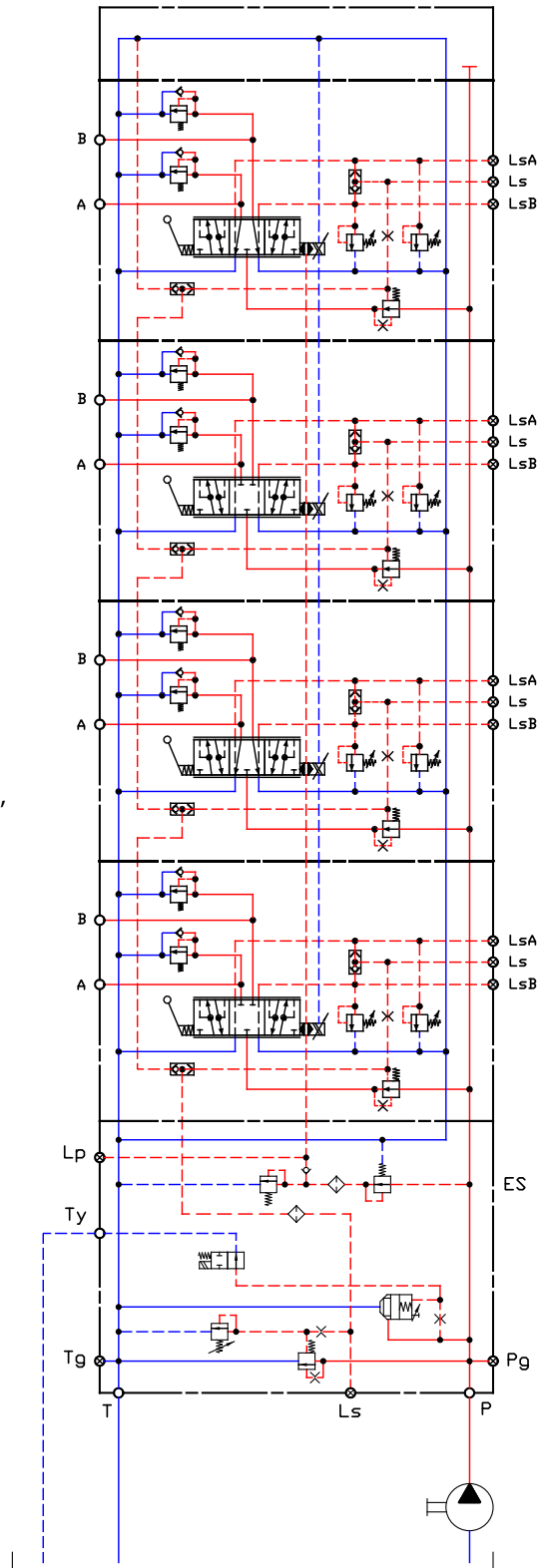

PDV74 with closed centre inlet section (variable displacement pump), pilot oil supply for electro-hydraulic spool actuations

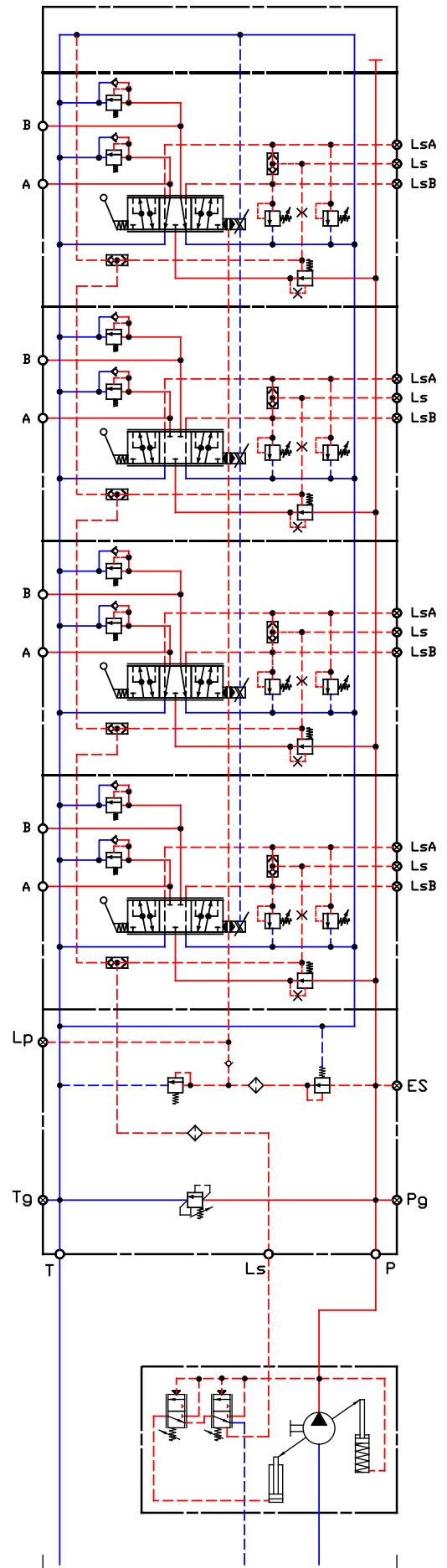

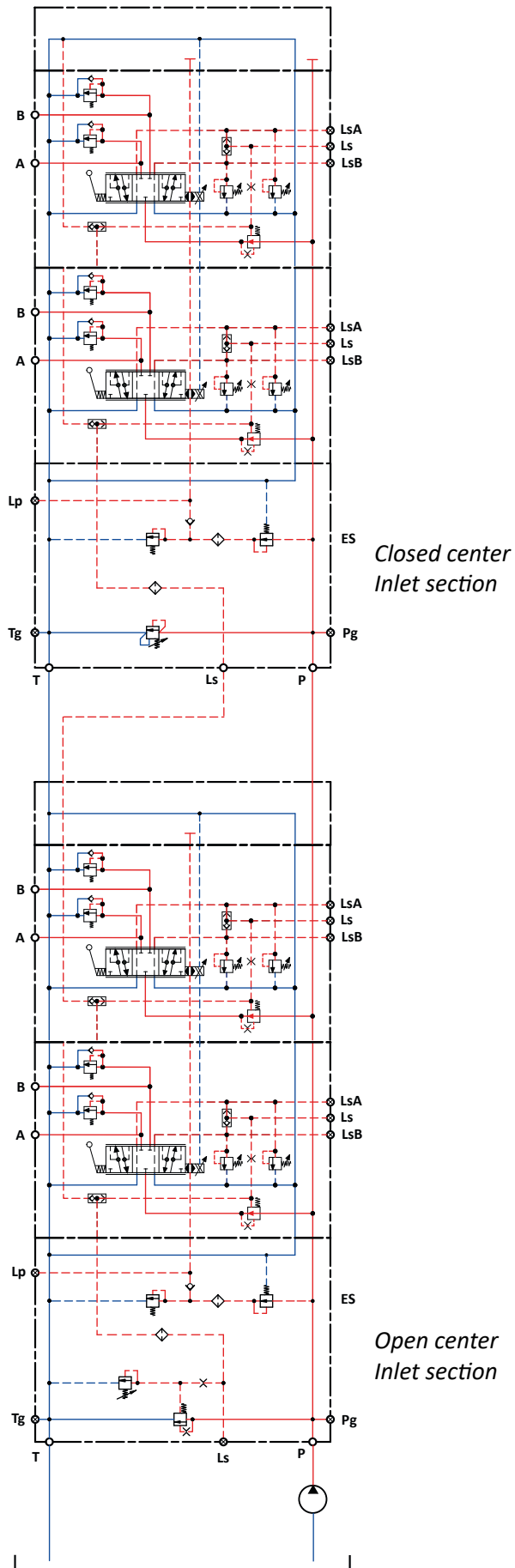

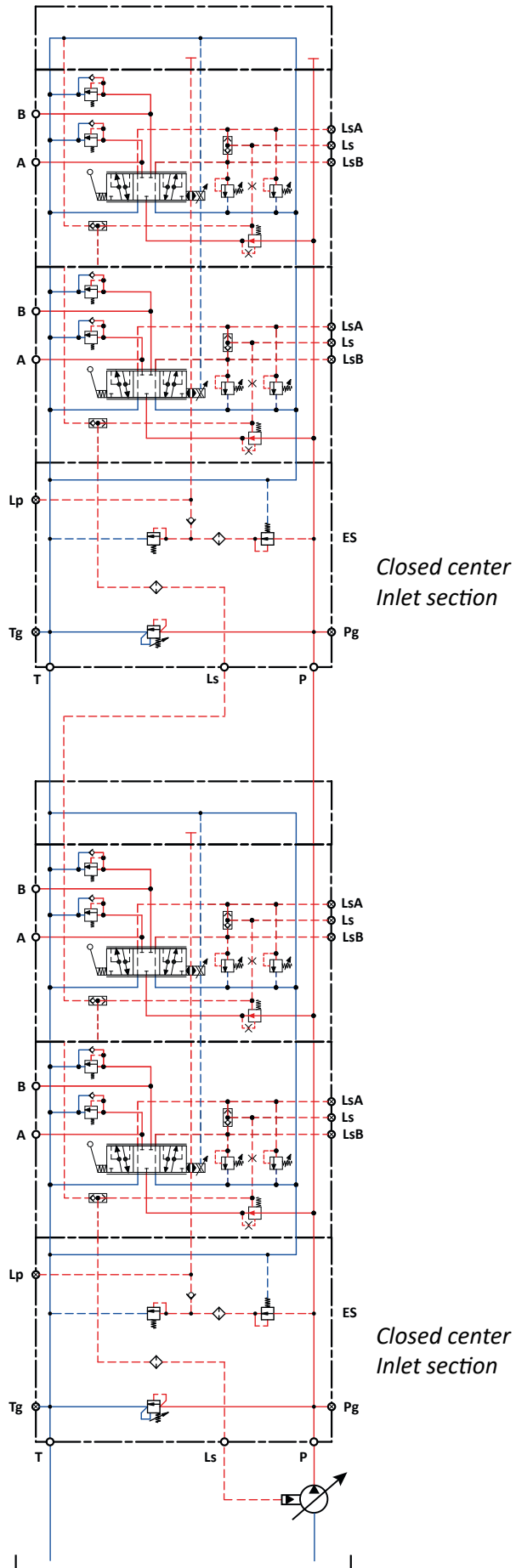

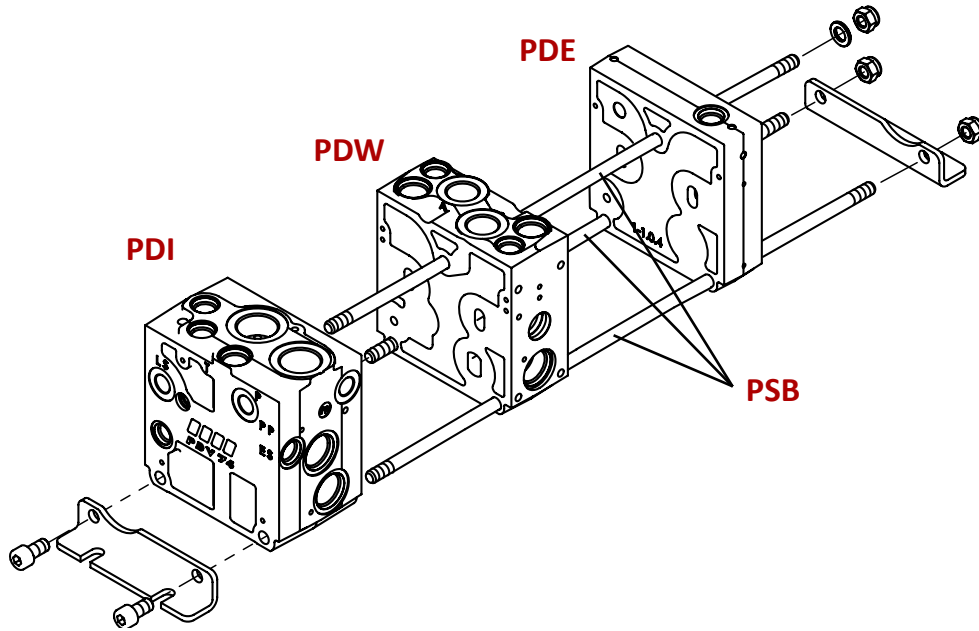

PDW	Code numbers	Tightening torque
1	PSB70011000	<p>25 ± 2 Nm 220 ± 18 lb*in</p>
2	PSB70021000	
3	PSB70031000	
4	PSB70041000	
5	PSB70051000	
6	PSB70061000	
7	PSB70071000	
8	PSB70081000	
9	PSB70091000	
10	PSB70101000	

PDV74 Proportional valve

Overall dimensions drawing with double inlet section and MID end

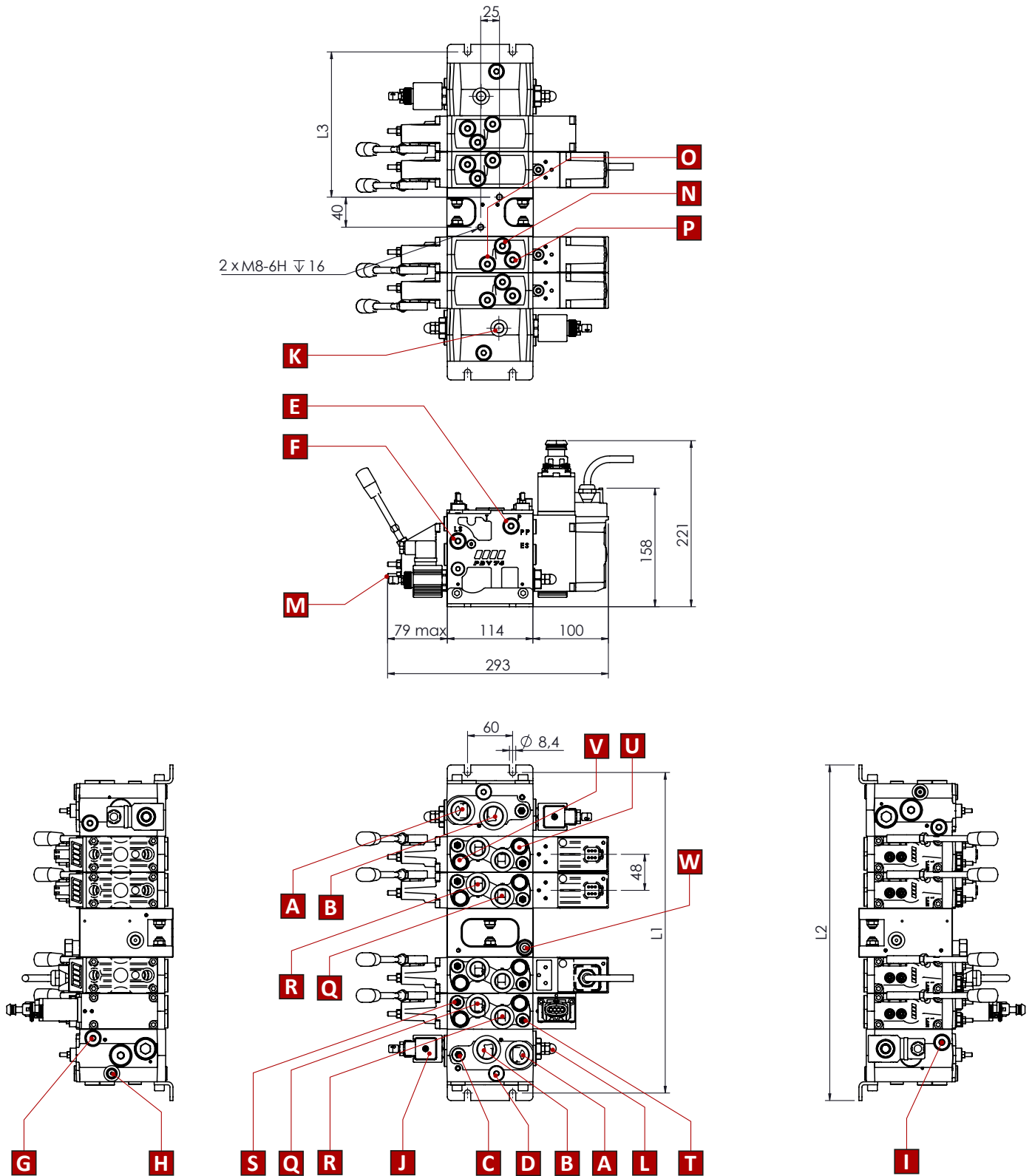

PDW		2	3	4	5	6	7	8	9	10	11	12
L1	mm	331	379	427	475	523	571	619	667	715	763	811
	in	13,03	14,92	16,81	18,70	20,59	22,48	24,37	26,26	28,15	30,04	31,93
L2	mm	351	399	447	495	543	591	639	687	735	783	831
	in	13,82	15,71	17,60	19,49	21,38	23,27	25,16	27,05	28,94	30,83	32,72

- A** = Pump side port - 3/4" BSPP - 17 mm deep [1 1/16 in 12 UN-2B - 0,67 in deep]
 - B** = T port - 3/4" BSPP - 17 mm deep [1 1/16 in 12 UN - 2B - 0,67 in deep]
 - C** = Main pressure relief valve
 - D** = Main pressure reducing valve
 - E** = Pump pressure gauge connection - 1/4" BSPP - 12 mm deep [7/16 in-20 UNF-2B - 0,47 in deep]
 - F** = LS connection 1/4" BSPP - 12 mm deep [7/16 in-20 UNF-2B - 0,47 in deep]
 - G** = External pilot pressure supply connection 1/4" BSPP - 12 mm deep [7/16 in-20 UNF-2B - 0,47 in deep]
 - H** = External feeding main pressure reducing valve 1/4" BSPP - 12 mm deep [7/16 in-20 UNF-2B - 0,47 in deep]
 - I** = Tank pressure gauge connection 1/4" BSPP - 12 mm deep [7/16 in-20 UNF-2B - 0,47 in deep]
 - J** = Electrical LS/pump unloading function
 - K** = Pump unloading drain port, 1/4" BSPP - 12 mm deep [7/16 in-20 UNF - 2B - 0,47 in deep]
 - L** = Pump unloading mechanical override
 - M** = A-B port mechanical flow adjustment
 - N** = LSA
 - O** = LSB
 - P** = LS
 - Q** = Port A
 - R** = Port B
 - S** = LSB
 - T** = LSA
 - U** = Shock/suction valve B port
 - V** = Shock/suction valve A port
 - W** = External drain connection electric actuations - 1/4" BSPP - 12 mm deep [7/16 in-20 UNF-2B - 0,47 in deep]
- } remote pilot pressure connection 1/4" BSPP - 12 mm deep [7/16 in-20 UNF - 2B - 0,47 in deep]
 } 1/2" BSPP - 17 mm deep [7/8 in-14 UNF-2B - 0,67 in deep]
 } pilot pressure relief valve

PDV74 with double closed centre inlet section (variable displacement pump), pilot oil supply for electro-hydraulic spool actuations

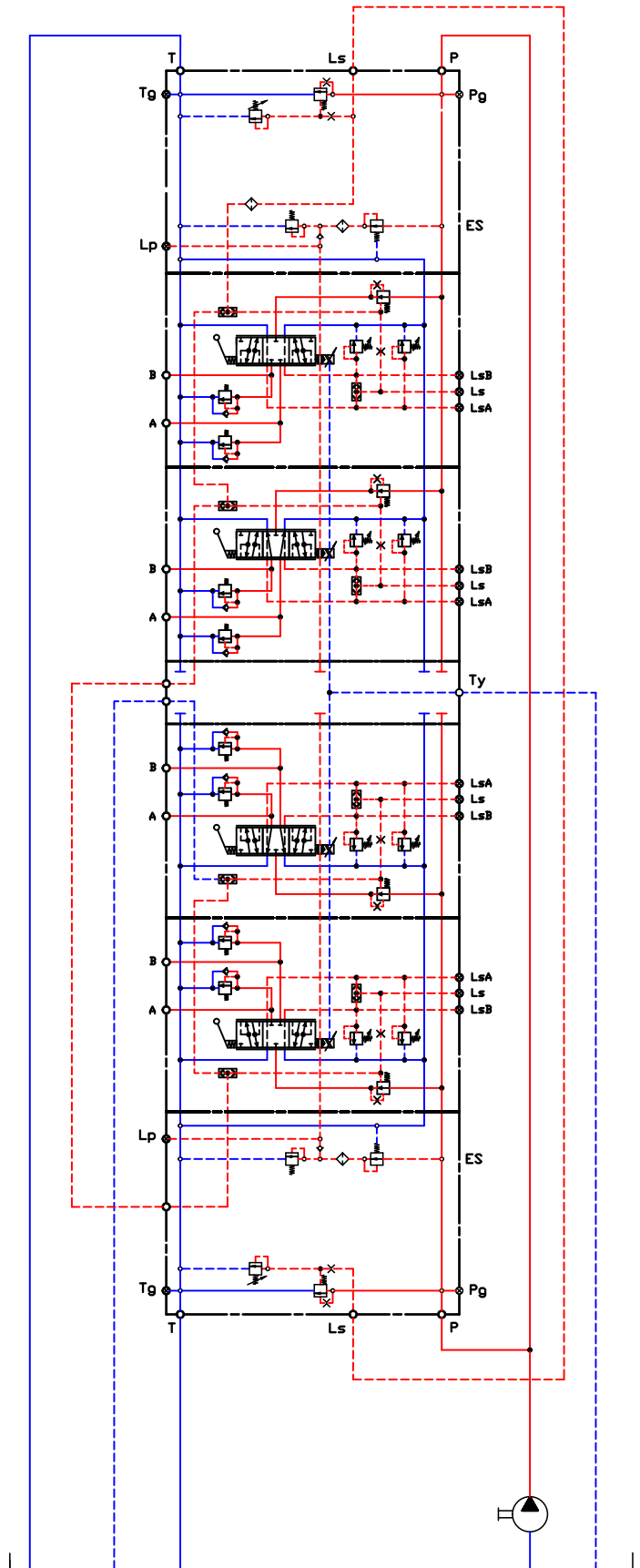

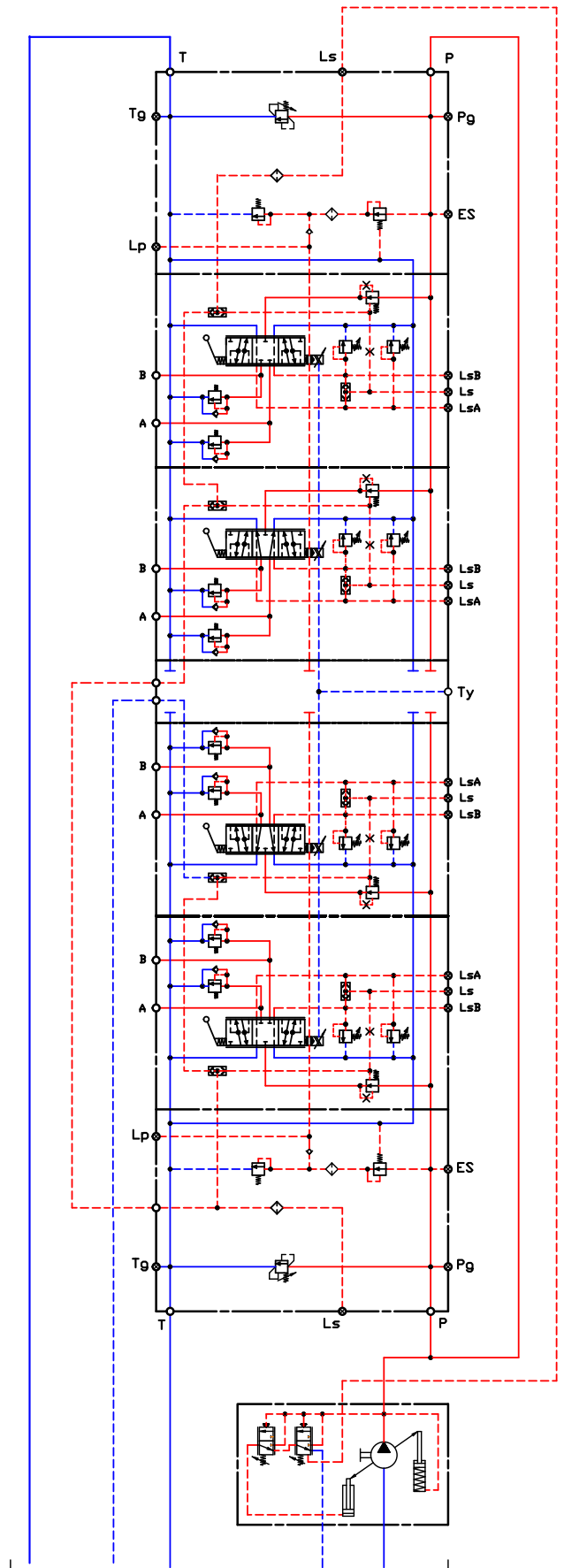

PDV74 Proportional Valve
PSB Stay bolt kit - Double inlet sections and
 MID end section configuration

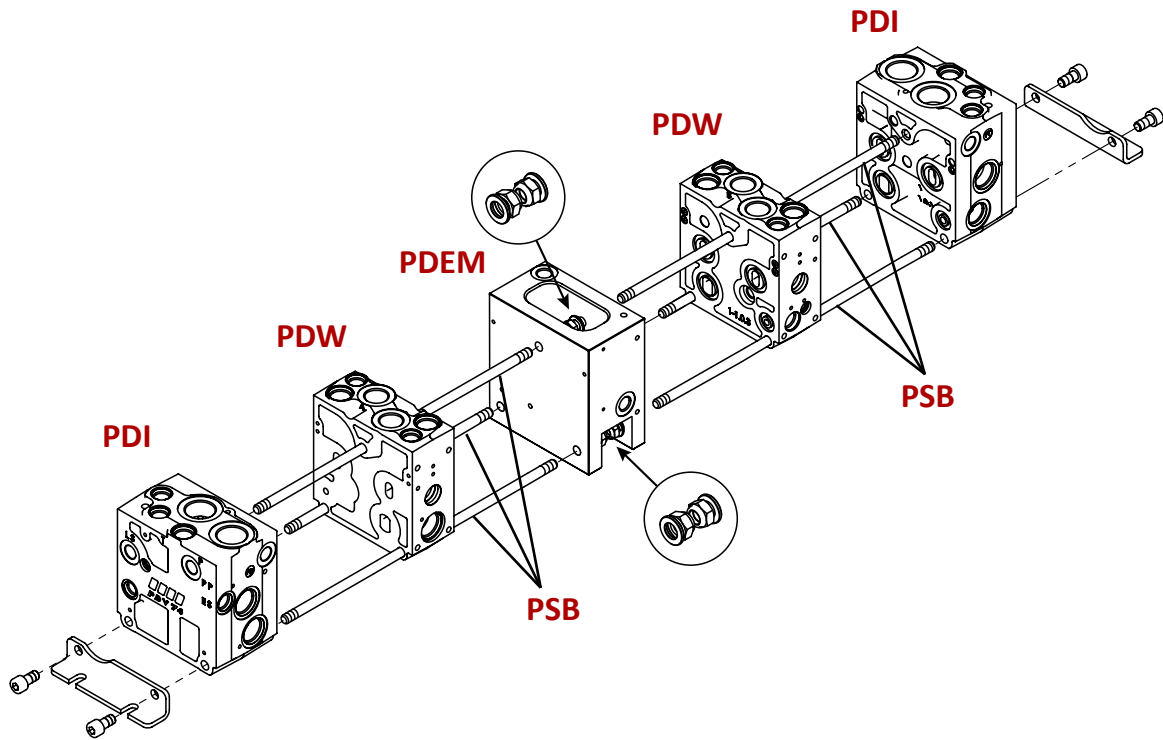

PDW	Code numbers	Tightening torque
1	PSB72011000	25 ± 2 Nm 220 ± 18 lb*in
2	PSB72021000	
3	PSB72031000	
4	PSB72041000	
5	PSB72051000	
6	PSB72061000	

PDV74 Proportional valve
Overall dimensions drawing with closed centre MID inlet section

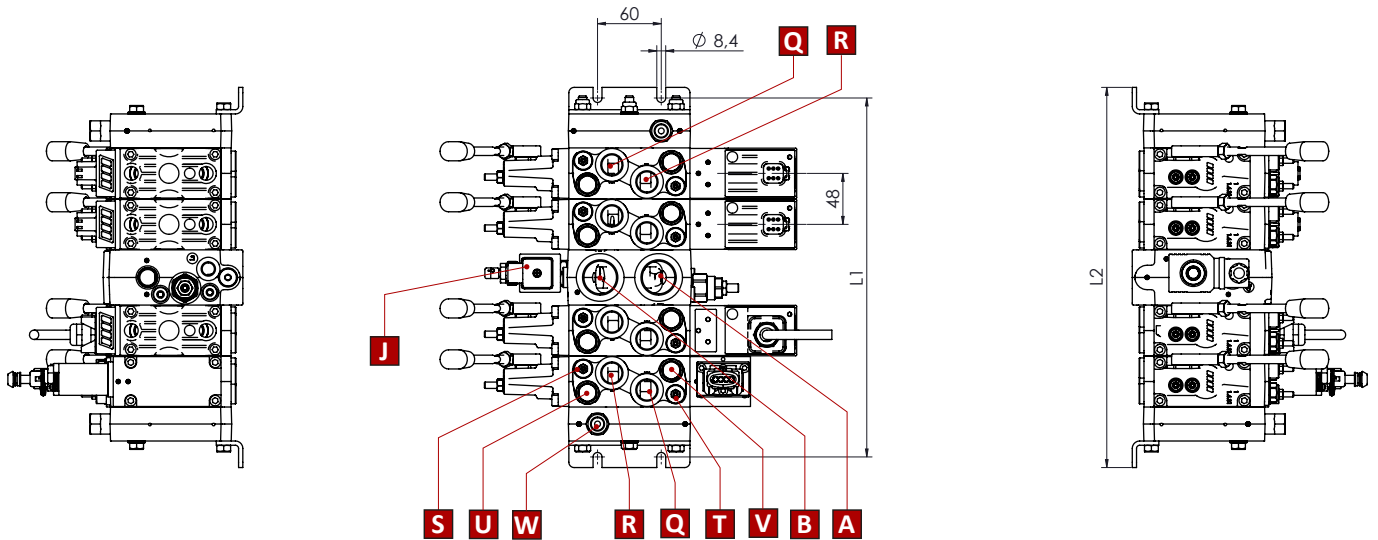
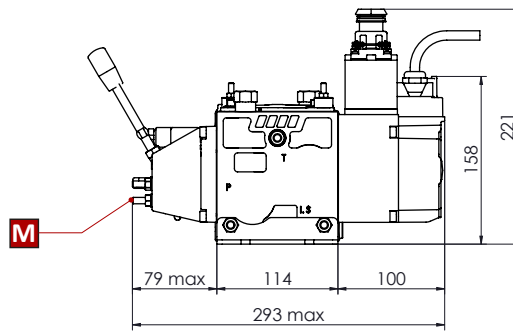
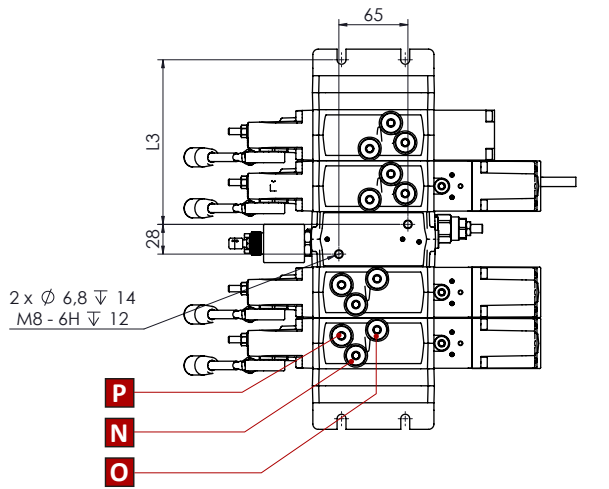

- A** = Pump side port - 3/4" BSPP - 17 mm deep [1 1/16 in 12 UN-2B - 0,67 in deep]
 - B** = T port - 3/4" BSPP - 17 mm deep [1 1/16 in 12 UN - 2B - 0,67 in deep]
 - C** = Main pressure relief valve
 - D** = Main pressure reducing valve
 - E** = Pump pressure gauge connection - 1/4" BSPP - 12 mm deep [7/16 in-20 UNF-2B - 0,47 in deep]
 - F** = LS connection 1/4" BSPP - 12 mm deep [7/16 in-20 UNF-2B - 0,47 in deep]
 - G** = External pilot pressure supply connection 1/4" BSPP - 12 mm deep [7/16 in-20 UNF-2B - 0,47 in deep]
 - H** = External feeding main pressure reducing valve 1/4" BSPP - 12 mm deep [7/16 in-20 UNF-2B - 0,47 in deep]
 - I** = Tank pressure gauge connection 1/4" BSPP - 12 mm deep [7/16 in-20 UNF-2B - 0,47 in deep]
 - J** = Electrical LS/pump unloading function
 - K** = Pump unloading drain port, 1/4" BSPP - 12 mm deep [7/16 in-20 UNF - 2B - 0,47 in deep]
 - L** = Pump unloading mechanical override
 - M** = A-B port mechanical flow adjustment
 - N** = LSA
 - O** = LSB
 - P** = LS
 - Q** = Port A
 - R** = Port B
 - S** = LSA
 - T** = LSA
 - U** = Shock/suction valve B port
 - V** = Shock/suction valve A port
 - W** = External drain connection electric actuations - 1/4" BSPP - 12 mm deep [7/16 in-20 UNF-2B - 0,47 in deep]
- } remote pilot pressure connection 1/4" BSPP - 12 mm deep [7/16 in-20 UNF - 2B - 0,47 in deep]
 } 1/2" BSPP - 17 mm deep [7/8 in-14 UNF-2B - 0,67 in deep]
 } pilot pressure relief valve

PDV74 with MID-inlet closed centre section
(variable displacement pump), pilot oil supply for
electro-hydraulic spool actuations

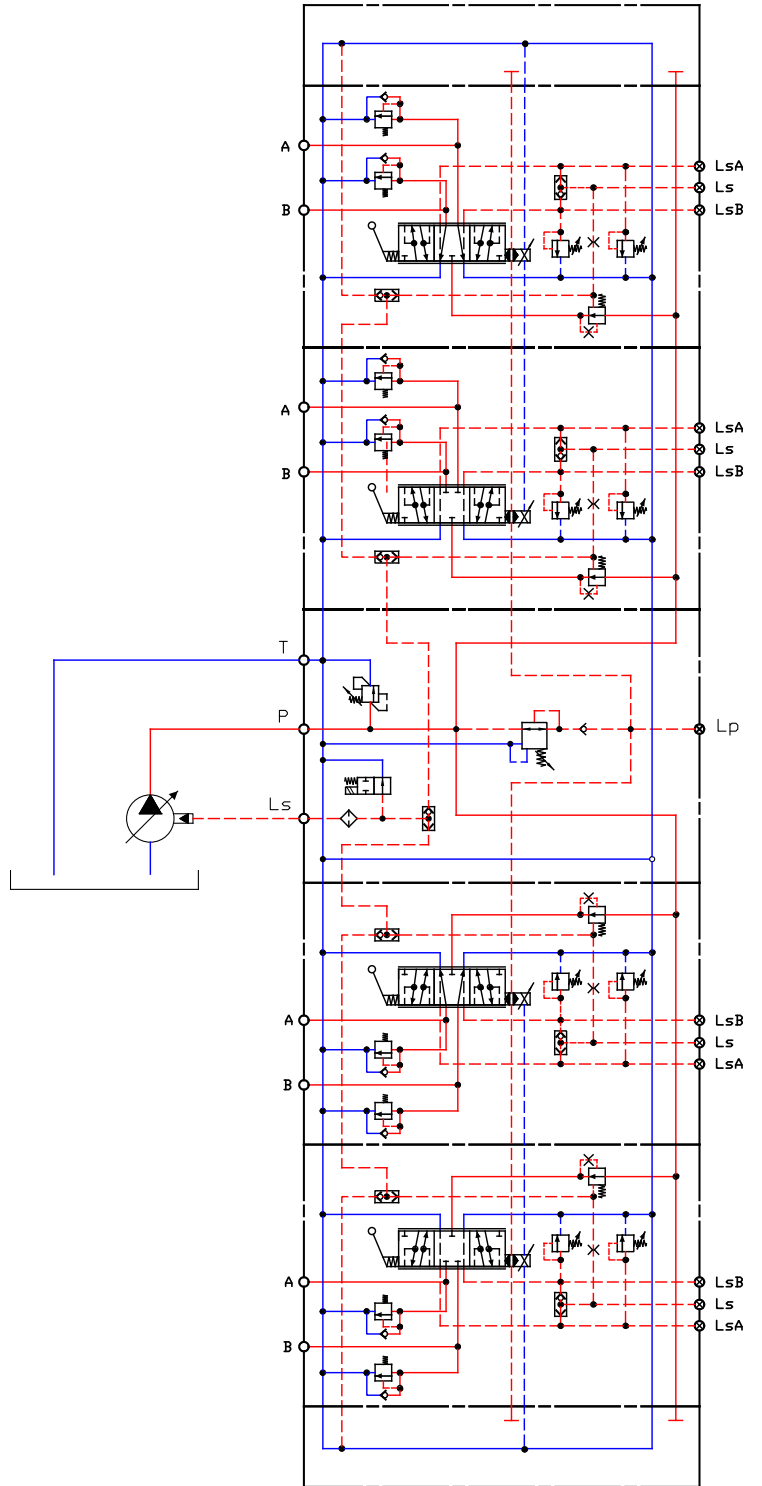

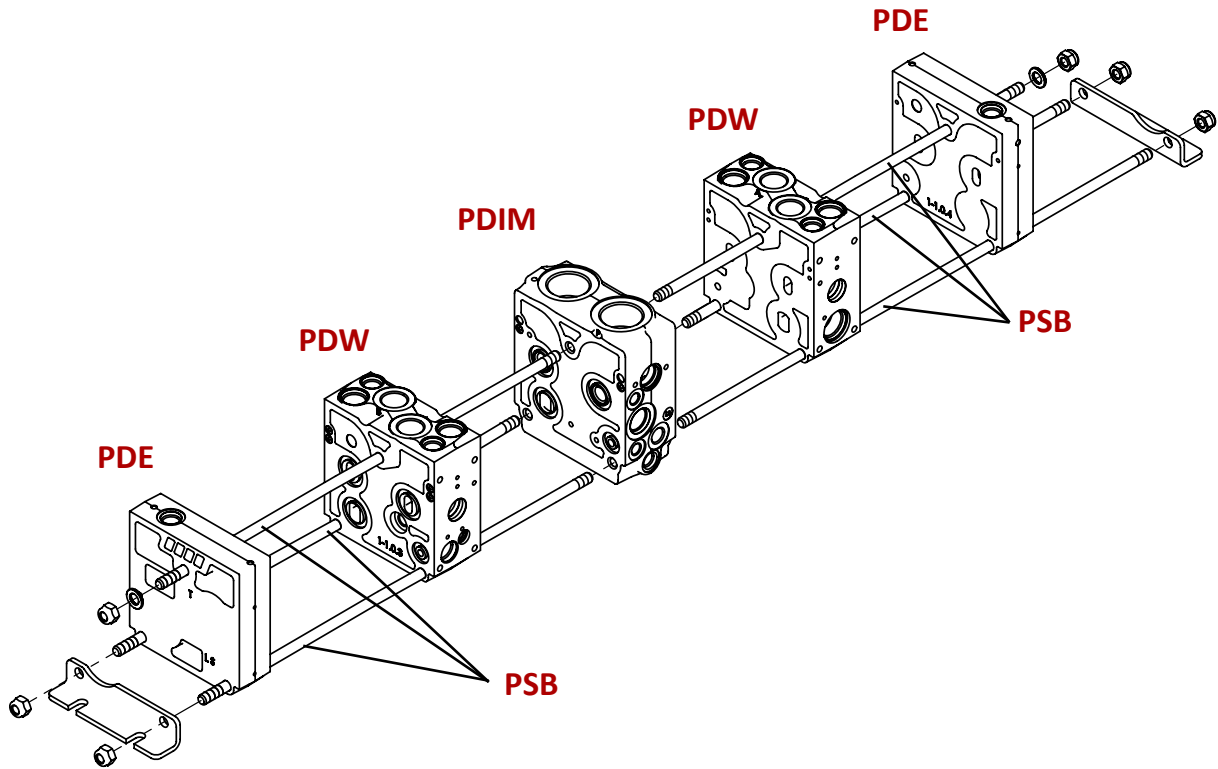

PDW	Code numbers	Tightening torque
1	PSB71011000	25 ± 2 Nm 220 ± 18 lb*in
2	PSB71021000	
3	PSB71031000	
4	PSB71041000	
5	PSB71051000	
6	PSB71061000	

PDV74 Proportional valve
Right side version

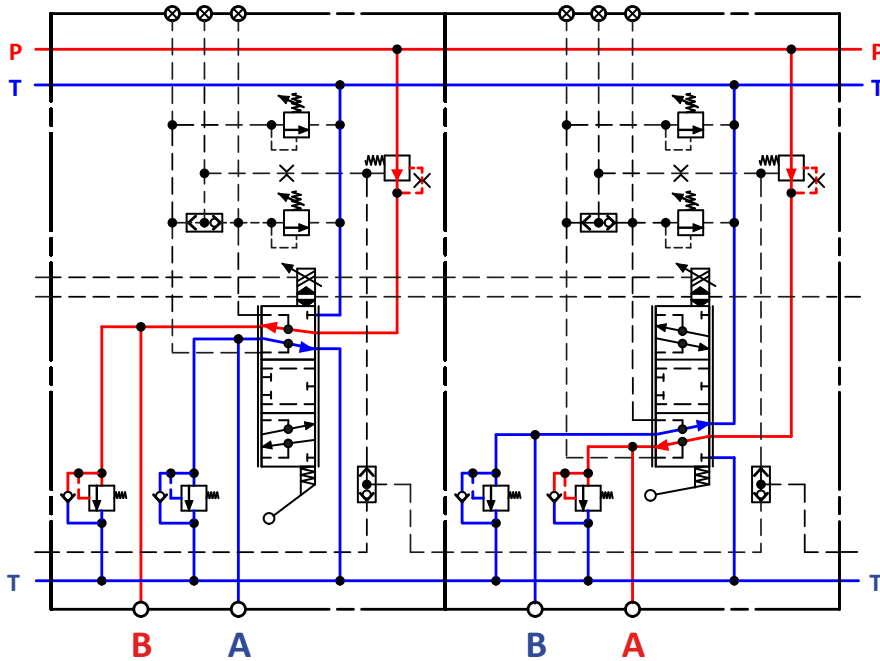
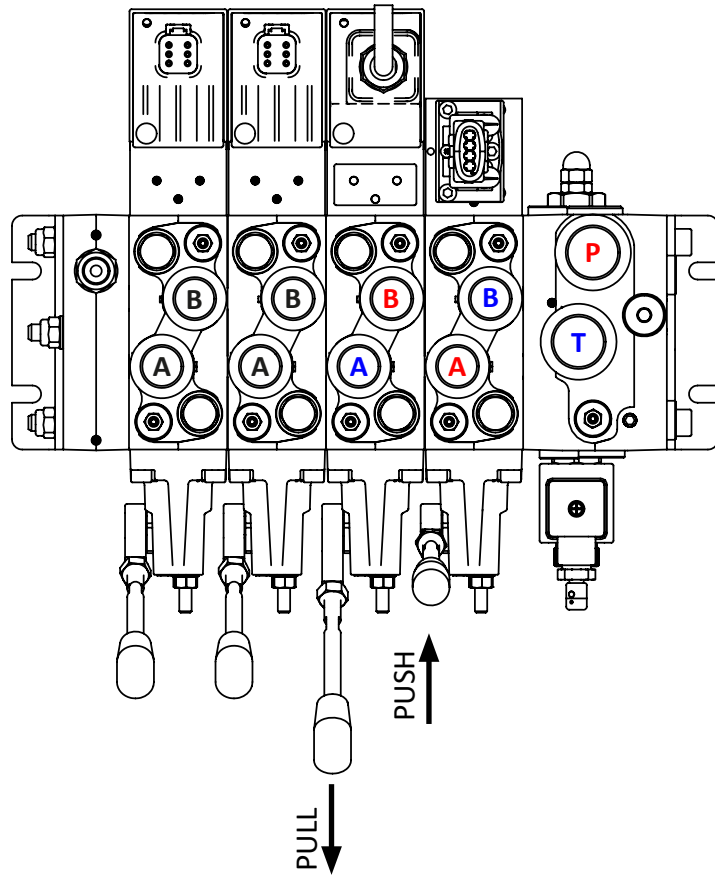

PDV74 Proportional valve
Left side version

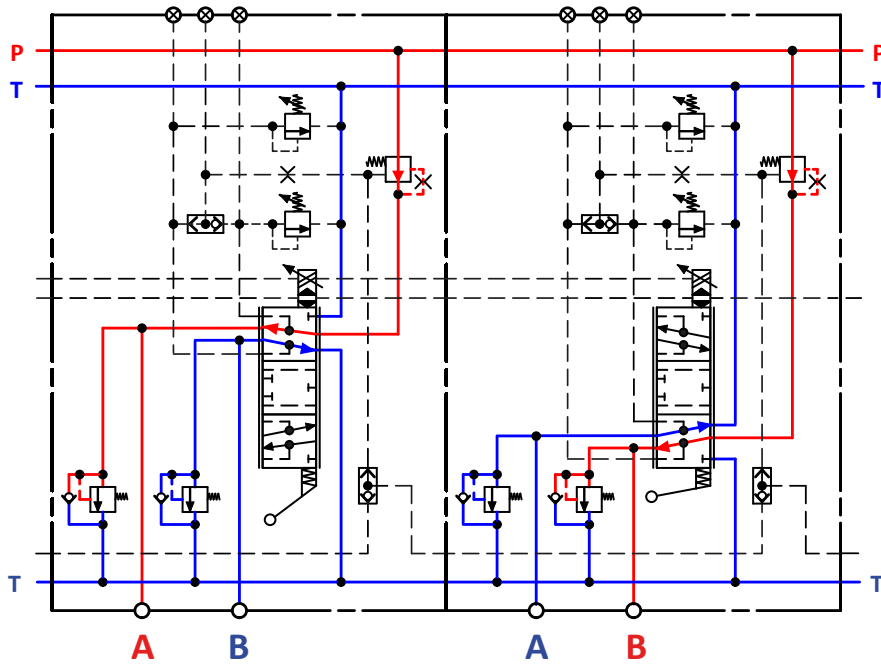
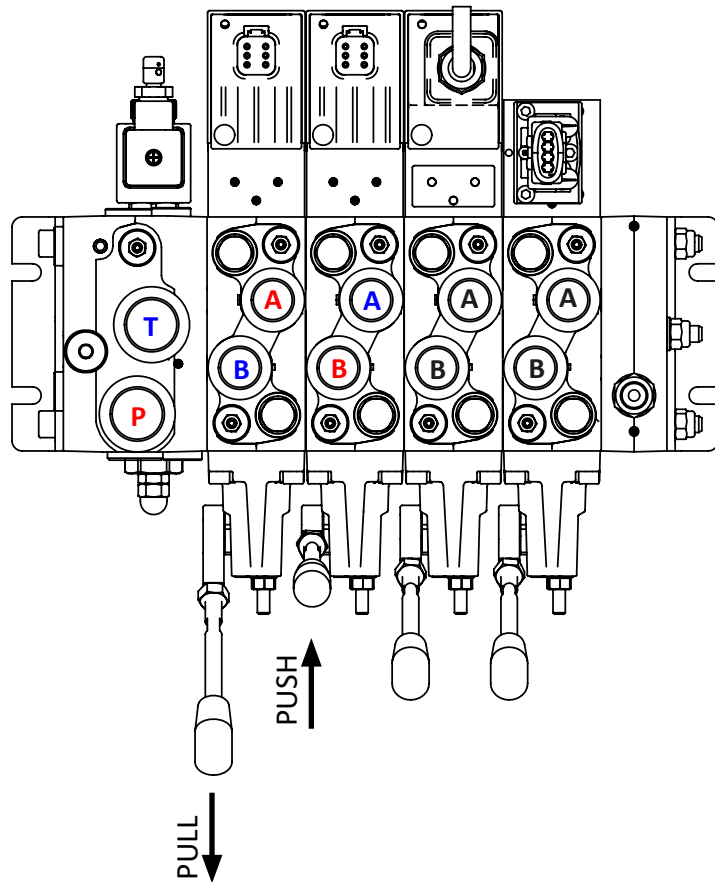

PDV74 Proportional valve Configuration with standard inlet section - Right side assembly Product selection chart

This specification sheet, gives an overview of any modules with which the PDV74 is being assembled. Each module has its own field. The purpose of this chart is to provide a quick access to the module's choice, whose characteristics must always be checked on the catalog related data.

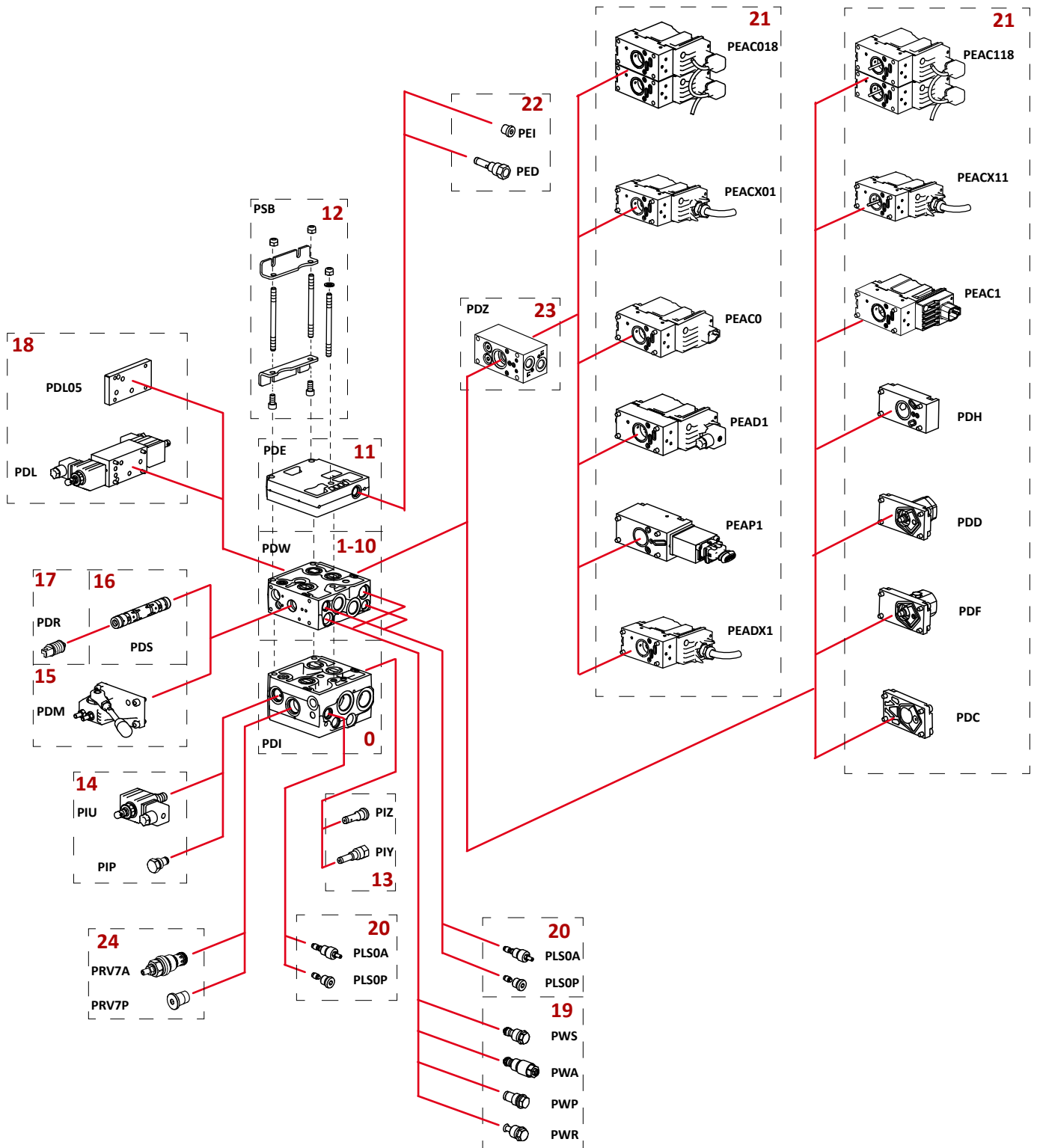

Reference field	Description		Code numbers see pag
0	Inlet sections	Open centre	PDI 18 - 19
		Closed centre	21 - 22
1-10	Working sections	with pressure compensator	PDW 25 - 26
		without pressure compensator	27 - 28
11	End sections		PDE 29 - 30
12	Stay bolt set		PSB 118
13	Pilot oil supply cartridge	Internal	PIZ 45
		External	PIY 45
14	Solenoid Ls unloading		PIU 23 - 24
	Plug for LS unloading cavity		PIP 23
15	Mechanical actuation		PDM 42
16	Spool		PDS From 33 to 41
17	Spool centered set		PDR From 35 to 41
18	Unloading module		PDL From 49 to 53
	Cover plate		PDL05
19	Shock and suction valve	not adjustable	PWS 46 - 47
		adjustable	PWA 46 - 47
	Plug for shock and suction valve cavity		PWP 48
	Suction valve		PWR 48
20	Pilot pressure LS _{A/B} relief valve		PLS0A 43
	Set plug LS _{A/B} cavity		PLS0P 43
21	Proportional electro-hydraulic actuations	Open loop spool control current signal for PWM and ON-OFF control	PEAD1 From 99 to 104
		Open loop spool control high resolution	PEAC0 From 78 to 98
		Closed loop spool control high performance resolution	PEAC1 From 54 to 77
		Open loop spool control high resolution CAN-Bus	PEAC018
		Closed loop spool control high performance resolution CAN-Bus	PEAC118
		Open loop spool control high resolution ATEX	PEACX01
		Closed loop spool control high performance resolution ATEX version	PEACX11
		Open loop spool control current signal for PWM and ON-OFF control ATEX version	PEADX1
		Open loop spool control current input signal for PWM and ON-OFF control - AMP JPT 4 pin	PEAP1 From 105 to 110
	Rear cover for	Hydraulic control	PDH 43
		Detent	PDD 44
		Friction detent	PDF 42
		Mechanical actuation	PDC 43
22	End sections	External drain line cartridge	PED 45
		Internal plug	PEI 45
23	Dual function control body		PDZ 31 - 32
24	Pump pressure relief valve (for closed centre only)		PRV0A
	Plug for relief valve cavity (for closed centre only)		PRV0P

PDV74 Proportional valve, product selection chart

Configuration with double inlet sections and MID end section

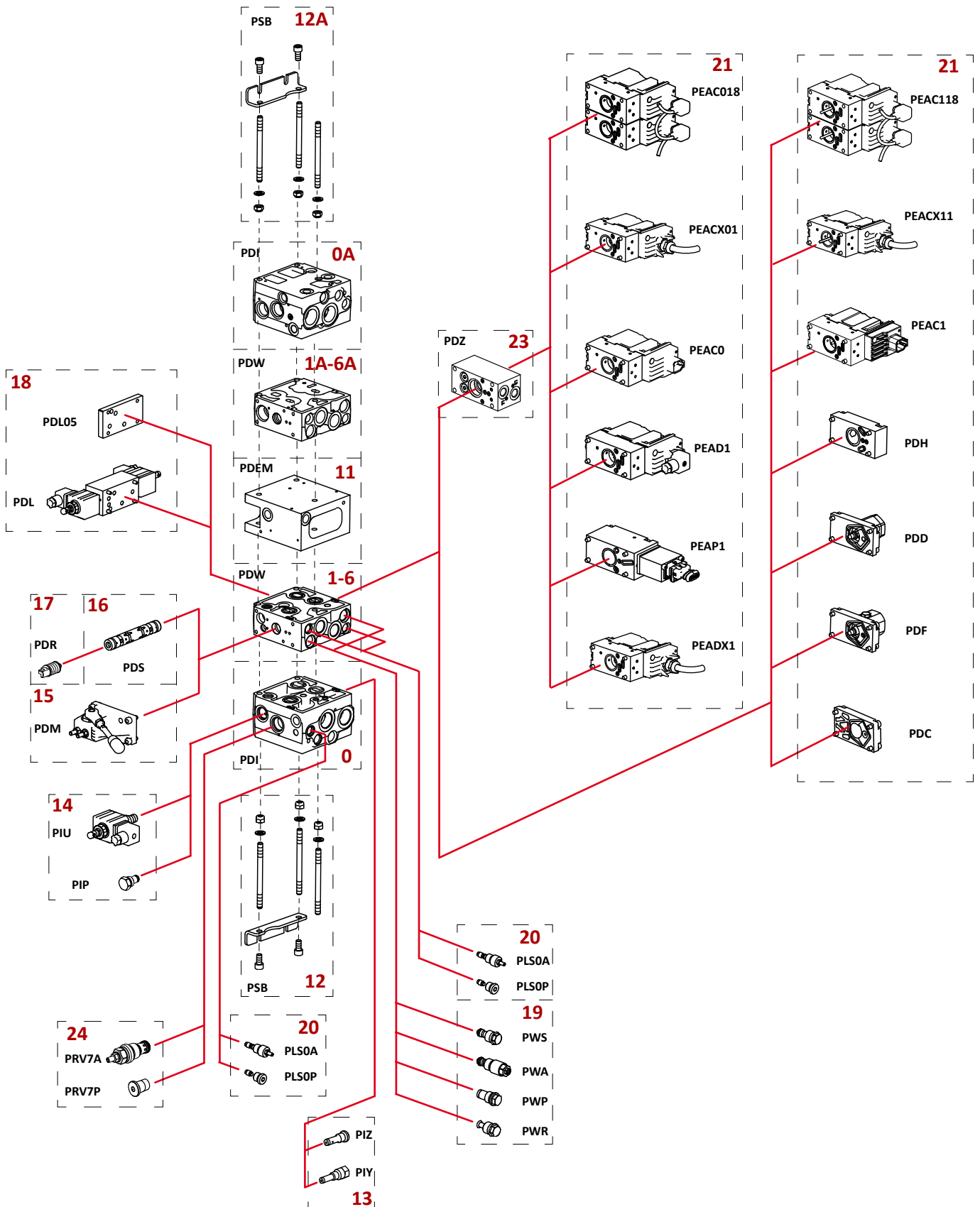

Reference field	Description			Code numbers see pag
0 0A	Inlet sections	Open centre	PDI	18 - 19
		Closed centre		21 - 22
1-6 1A-6A	Working sections	with pressure compensator	PDW	25 - 26
		without pressure compensator		27 - 28
11	End sections		PDEM	30
12 12A	Stay bolt set		PSB	124
13	Pilot oil supply cartridge	Internal	PIZ	45
		External	PIY	45
14	Solenoid Ls unloading		PIU	23 - 24
	Plug for LS unloading cavity		PIP	23
15	Mechanical actuation		PDM	42
16	Spool		PDS	From 33 to 41
17	Spool centered set		PDR	From 35 to 41
18	Unloading module		PDL	From 49 to 53
	Cover plate		PDL05	
19	Shock and suction valve	not adjustable	PWS	46 - 47
		adjustable	PWA	46 - 47
	Plug for shock and suction valve cavity		PWP	48
	Suction valve		PWR	48
20	Pilot pressure LS _{A/B} relief valve		PLS0A	43
	Set plug LS _{A/B} cavity		PLS0P	43
21	Proportional electro-hydraulic actuations	Open loop spool control current signal for PWM and ON-OFF control	PEAD1	From 99 to 104
		Open loop spool control high resolution	PEAC0	From 78 to 98
		Closed loop spool control high performance resolution	PEAC1	From 54 to 77
		Open loop spool control high resolution CAN-Bus	PEAC018	
		Closed loop spool control high performance resolution CAN-Bus	PEAC118	
		Open loop spool control high resolution ATEX	PEACX01	
		Closed loop spool control high performance resolution ATEX version	PEACX11	
		Open loop spool control current signal for PWM and ON-OFF control ATEX version	PEADX1	
	Open loop spool control current input signal for PWM and ON-OFF control - AMP JPT 4 pin	PEAP1	From 105 to 110	
	Rear cover for	Hydraulic control	PDH	43
Detent		PDD	44	
Friction detent		PDF	42	
Mechanical actuation		PDC	43	
22	End sections	External drain line cartridge	PED	45
		Internal plug	PEI	45
23	Dual function control body		PDZ	31 - 32
24	Pump Pressure relief valve (for closed centre only)		PRV0A	
	Plug for relief valve cavity (for closed centre only)		PRV0P	

PDV74 Proportional valve, product selection chart Configuration with MID inlet section

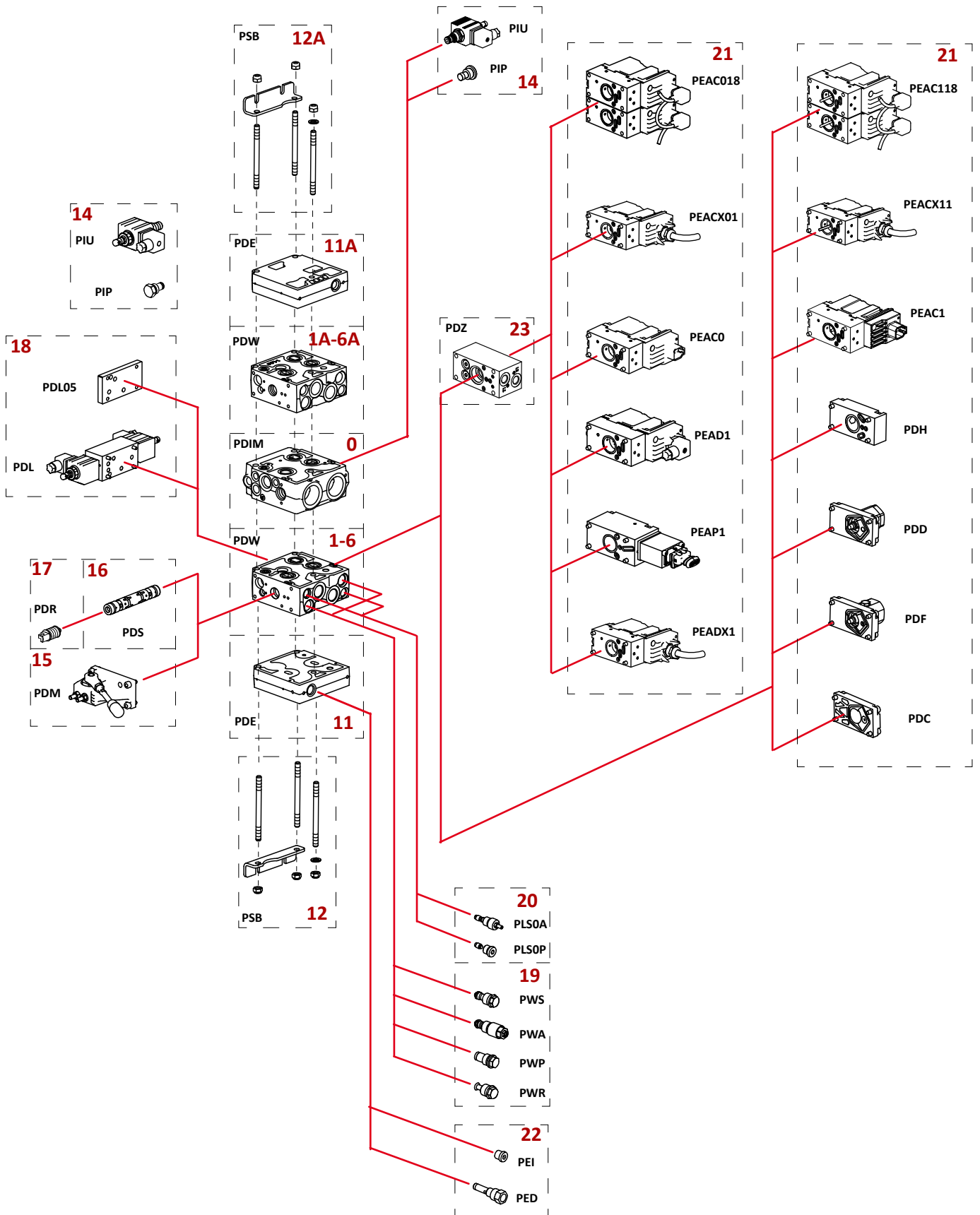

Reference field	Description			Code numbers see pag
0	Inlet sections	Closed centre	PDIM	22
1-6 1A-6A	Working sections	with pressure compensator	PDW	25 - 26
		without pressure compensator		27 - 28
11 11A	End sections		PDE	29 - 30
12 12A	Stay bolt set		PSB	129
14	Solenoid Ls unloading		PIU	23 - 24
	Plug for LS unloading cavity		PIP	23
15	Mechanical actuation		PDM	42
16	Spool		PDS	From 33 to 41
17	Spool centered set		PDR	From 35 to 41
18	Unloading module		PDL	From 49 to 53
	Cover plate		PDL05	
19	Shock and suction valve	not adjustable	PWS	46 - 47
		adjustable	PWA	46 - 47
	Plug for shock and suction valve cavity		PWP	48
	Suction valve		PWR	48
20	Pilot pressure LS _{A/B} relief valve		PLS0A	43
	Set plug LS _{A/B} cavity		PLS0P	43
21	Proportional electro-hydraulic actuations	Open loop spool control current signal for PWM and ON-OFF control	PEAD1	From 99 to 104
		Open loop spool control high resolution	PEAC0	From 78 to 98
		Closed loop spool control high performance resolution	PEAC1	From 54 to 77
		Open loop spool control high resolution CAN-Bus	PEAC018	
		Closed loop spool control high performance resolution CAN-Bus	PEAC118	
		Open loop spool control high resolution ATEX	PEACX01	
		Closed loop spool control high performance resolution ATEX version	PEACX11	
		Open loop spool control current signal for PWM and ON-OFF control ATEX version	PEADX1	
		Open loop spool control current input signal for PWM and ON-OFF control - AMP JPT 4 pin	PEAP1	From 105 to 110
	Rear cover for	Hydraulic control	PDH	43
		Detent	PDD	44
		Friction detent	PDF	42
		Mechanical actuation	PDC	43
22	End sections	External drain line cartridge	PED	45
		Internal plug	PEI	45
23	Dual function control body		PDZ	31 - 32
24	Pump Pressure relief valve		PRV0A	
	Plug for relief valve cavity		PRV0P	

PDV74 Proportional valve
Composition form for standard inlet section

 HYDRAULIC POWER CONTROL		Code: PDV74			Customer:					
		Date: / /			Customer ref:					
		Review index: -			Issued by:					
		Review date: -			OMFB sales ref:					
I	Valve type:	PDV 74	V	Working sections Up:	10	IX	Rated voltage [V]:	12		
II	Type of threads:	BSP	VI	Working sections Down:		X	Certifications:	None		
III	Type of inlet:	standard	VII	Inlet section side:	Right version	XI				
IV	Pump type:	Open Center	VIII	2 nd pump type:		XII	Pump flow [l/min]:			
0	Notes	B Port	0	bar			13	A Port	Notes	
			20				14			
			Actuation side							Handle side
			24							
1	21		1	bar			bar	16	15	
	17		20					20		
	23		19					19		
			18							
2	21		2	bar			bar	16	15	
	17		20					20		
	23		19					19		
			18							
3	21		3	bar			bar	16	15	
	17		20					20		
	23		19					19		
			18							
4	21		4	bar			bar	16	15	
	17		20					20		
	23		19					19		
			18							
5	21		5	bar			bar	16	15	
	17		20					20		
	23		19					19		
			18							
6	21		6	bar			bar	16	15	
	17		20					20		
	23		19					19		
			18							
7	21		7	bar			bar	16	15	
	17		20					20		
			19					19		
			18							
8	21		8	bar			bar	16	15	
	17		20					20		
	23		19					19		
			18							
9	21		9	bar			bar	16	15	
	17		20					20		
	23		19					19		
			18							
10	21		10	bar			bar	16	15	
	17		20					20		
	23		19					19		
			18							
11			11					12		
			22							



HYDRAULIC POWER CONTROL

PDV74 Proportional valve

Composition form with double inlet section and MID End section

OMFB HYDRAULIC POWER CONTROL		Code: PDV74		Customer:	
		Date: / /		Customer ref:	
		Review index: -		Issued by:	
		Review date: -		OMFB sales ref:	
1 Valve type:	PDV 74	5 Working sections Up:	6	9 Rated voltage [V]:	12
2 Type of threads:	BSP	6 Working sections Down:	6	10 Certifications:	None
3 Type of inlet:	mid_end	7 Inlet section side:	Right version	11	
4 Pump type:	Open Center	8 2 nd pump type:		12 Pump flow [l/min]:	

Notes:	B Port	0A bar			13	A Port	Notes:
	Actuators side				14	Handle side	

1A	21	1A bar			bar	16		15
	17	20				20		
		19				19		
		18						
2A	21	2A bar			bar	16		15
	17	20				20		
		19				19		
		18						
3A	21	3A bar			bar	16		15
	17	20				20		
		19				19		
		18						
4A	21	4A bar			bar	16		15
	17	20				20		
		19				19		
		18						
5A	21	5A bar			bar	16		15
	17	20				20		
		19				19		
		18						
6A	21	6A bar			bar	16		15
	17	20				20		
		19				19		
		18						

11				12
12A				

6	21	6 bar			bar	16		15
	17	20				20		
		19				19		
		18						
5	21	5 bar			bar	16		15
	17	20				20		
		19				19		
		18						
4	21	4 bar			bar	16		15
	17	20				20		
		19				19		
		18						
3	21	3 bar			bar	16		15
	17	20				20		
		19				19		
		18						
2	21	2 bar			bar	16		15
	17	20				20		
		19				19		
		18						
1	21	1 bar			bar	16		15
	17	20				20		
		19				19		
		18						

Notes:	A Port	0 bar			13	B Port
	Actuators side				14	Handle side

PDV74 Proportional valve Composition form with MID inlet section

OMFB HYDRAULIC POWER CONTROL		Code: PDV74				Customer:			
		Date: / /				Customer ref:			
		Review index: -				Issued by:			
		Review date: -				OMFB sales ref:			
1	Valve type:	PDV 74	5	Working sections Up:	6	9	Rated voltage [V]:	12	
2	Type of threads:	BSPP	6	Working sections Down:	6	10	Certifications:	None	
3	Type of inlet:	mid_inlet	7	Inlet section side:	Right version	11			
4	Pump type:	Open Center	8	2 nd pump type:		12	Pump flow [l/min]:		

Notes:	A Port	11A			12A					Notes:
	Actuators side	22							B Port	

6A	21	6A	bar			bar	16		15
		17	20				20		
		19					19		
		18							
5A	21	5A	bar			bar	16		15
		17	20				20		
		19					19		
		18							
4A	21	4A	bar			bar	16		15
		17	20				20		
		19					19		
		18							
3A	21	3A	bar			bar	16		15
		17	20				20		
		19					19		
		18							
2A	21	2A	bar			bar	16		15
		17	20				20		
		19					19		
		18							
1A	21	1A	bar			bar	16		15
		17	20				20		
		19					19		
		18							

0	bar				14
---	-----	--	--	--	----

1	21	1	bar			bar	16		15
		17	20				20		
		19					19		
		18							
2	21	2	bar			bar	16		15
		17	20				20		
		19					19		
		18							
3	21	3	bar			bar	16		15
		17	20				20		
		19					19		
		18							
4	21	4	bar			bar	16		15
		17	20				20		
		19					19		
		18							
5	21	5	bar			bar	16		15
		17	20				20		
		19					19		
		18							
6	21	6	bar			bar	16		15
		17	20				20		
		19					19		
		18							

Notes:	B Port	11			12					Notes:
	Actuators side	22							A Port	