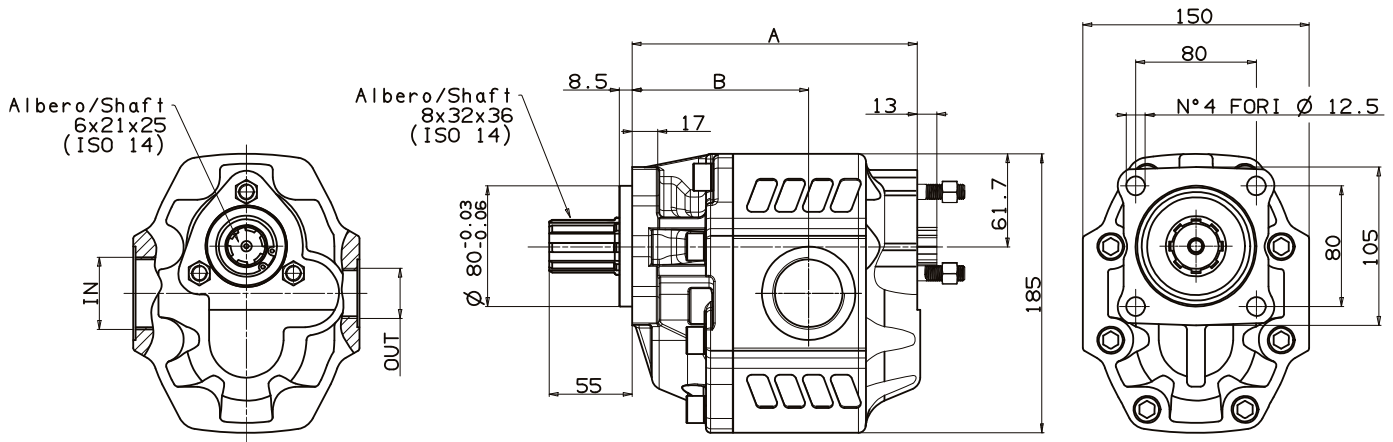

Fluido idraulico <i>Fluid</i>	Minerale o sintetico compatibile con guarnizioni: <i>Mineral or synthetic compatible with the following seals:</i> NBR, FKM, FPM, Nylon				
Viscosità cinematica consigliata <i>Kinematic viscosity suggested</i>	T media ambiente (°C) <i>Average ambient temp. (°C)</i>	< -10	-10÷10	10÷35	> 35
	VG (cSt = mm <sup>2</sup> /s)	22	32	46	68
Viscosità cinematica ottimale di esercizio <i>Optimale kinematic viscosity</i>			VG= 10 cSt ÷ 100 cSt		
Viscosità cinematica max consentita all'avviamento <i>Max kinematic viscosity suggested at the start-up</i>			VG= 750 cSt		
Indice di viscosità consigliato <i>Viscosity index suggested</i>		VI > 100	Temperatura di esercizio <i>Working temperature</i>		
			-15°C +100°C		
Grado di filtrazione <i>Oil filtering</i>			> 200 bar: 10 µm < 200 bar: 25 µm		
Pressione di aspirazione <i>Inlet pressure</i>			-0,3 ÷ 2 bar		
Senso di rotazione <i>Pump rotation</i>			Unidirezionale <i>Unidirectional</i>		

**Ingombro / Dimensions**

**Dati tecnici / Technical data**

Tipo pompa <i>Pump type</i>	Rotazione <i>Rotation</i>		IN	OUT	A	B	Peso <i>Weight</i>
	<i>Destra / Right</i>	<i>Sinistra / Left</i>					
<b>NPGH-63</b>	10507000638	10507000647	ISO 228	ISO 228	mm	mm	Kg
<b>NPGH-73</b>	10507000736	10507000745	G 1	G 3/4	158	95	18
<b>NPGH-84</b>	10507000843	10507000852			162	99	18.1
<b>NPGH-100</b>	10507001002	10507001011	G 1 1/4	G 1	166	99.5	18.8
<b>NPGH-116</b>	10507001164	10507001173			172	103	19.5
<b>NPGH-133</b>	10507001333	10507001342	G 1 1/2		178	109	20.1
<b>NPGH-150</b>	10507001502	10507001511			184	112	21
					189	117	21.5

**POMPE DA NON UTILIZZARE CON CARICHI ASSIALI E RADIALI SULL'ALBERO**  
 NO AXIAL AND RADIAL LOADS ALLOWED ON PUMP SHAFT

**PREDISPOSTA PER 2ª POMPA CON FLANGIA UNI**  
 READY FOR 2<sup>ND</sup> PUMP WITH UNI FLANGE

**Kit guarnizioni / Seal Kit**

6	10590000302
7	
11	
13	
14	
15	

+

1	50602335527
---	-------------

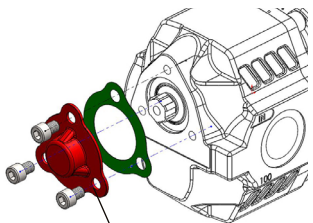

Kit protezione  
Protection kit  
**11400001641**

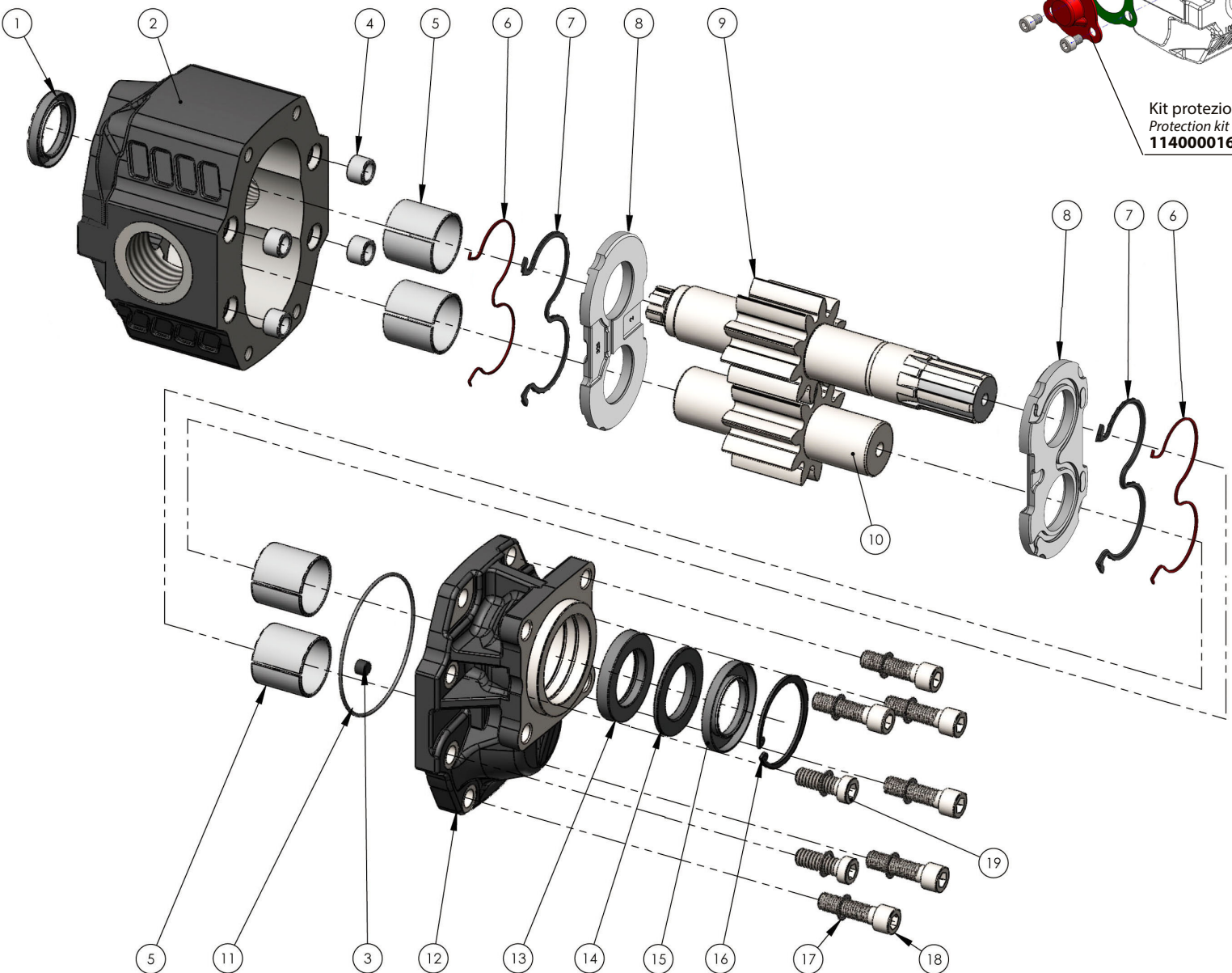

N°	63	73	84	100	116	133	150	Codice/Code	Descrizione / Description		Q.
1	.	.	.	.	.	.	.	50602335527	Guarnizione paraolio	Oil seal	1
2	.							51702000635 Dx/Right	Corpo pompa	Gear housing	1
	.							51702010633 Sx/Left			
		.						51702000724 Dx/Right			
		.						51702010722 Sx/Left			
			.					51702000840 Dx/Right			
			.					51702010848 Sx/Left			
				.				51702001009 Dx/Right			
				.				51702011007 Sx/Left			
					.			51702001161 Dx/Right			
					.			51702011169 Sx/Left			
						.		51702001321 Dx/Right			
						.		51702011329 Sx/Left			
						.	51702001509 Dx/Right				
						.	51702011507 Sx/Left				
3	.	.	.	.	.	.	.	50401000063	Grano conico 1/8"	Plug 1/8"	1
4	.	.	.	.	.	.	.	50100300291	Spine forate di centraggio 18x12.5	Bushing 18x12.5	4
5	.	.	.	.	.	.	.	53300400088	Boccole autolub. 38x42x38	Bushing 38x42x38	4
6	.	.	.	.	.	.	.	50600001195	Guarnizione antiestrusione	Back-up ring	2
7	.	.	.	.	.	.	.	50600001186	Guarnizione per rasamento	Thrust plate seal	2
8	.	.	.	.	.	.	.	51001000328	Rasamento ad occhiale	Thrust plate	2
9	.							52302900633	Albero dentato conduttore	Drive shaft	1
		.						52302900722			
			.					52302900848			
				.				52302901007			
					.			52302901169			
						.		52302901329			
10	.							52302000632	Albero dentato condotto	Driven shaft	1
		.						52302000721			
			.					52302000847			
				.				52302001006			
					.			52302001168			
						.		52302001328			
						.	52302001506				
11	.	.	.	.	.	.	.	50600001337	Guarnizione OR	O-Ring	1
12	.	.	.	.	.	.	.	51800300216	Coperchio anteriore	Mounting cover	1
13	.	.	.	.	.	.	.	50602138624	Guarnizione paraolio	Oil seal	1
14	.	.	.	.	.	.	.	50602238623	Anello schermo paraolio	Oil seal guard ring	1
15	.	.	.	.	.	.	.	50600738627	Guarnizione paraolio	Oil seal	1
16	.	.	.	.	.	.	.	50100100588	Anello seeger	Seeger ring	1
17	.	.	.	.	.	.	.	50102000129	Rondella elastica	Washer	8
18	.							50200500573	Vite TCE M12x45	Screw M12x45	6
		.	.	.	.	.	.				8
19	.							50200000265	Vite TCE M12x35	Screw M12x35	2

**CARATTERISTICHE TECNICHE DI FUNZIONAMENTO - TECHNICAL FEATURES**

Tipo pompa Pump type	Cilindrata Displacement  cm <sup>3</sup> /rev	Pressione Pressure			Velocità max. continua Max. continuous speed  rpm	Velocità max. intermittente Max. intermittent speed  rpm	Velocità min. Min. speed  rpm
		P1	P2	P3			
		bar	bar	bar			
<b>NPGH-63</b>	63.70	290	315	325	1800	2700	300
<b>NPGH-73</b>	74.87	280	300	315			
<b>NPGH-84</b>	85.96	260	280	290			
<b>NPGH-100</b>	102.60	250	270	280			
<b>NPGH-116</b>	119.24	240	260	270	1500	2500	
<b>NPGH-133</b>	135.88	220	250	260			
<b>NPGH-150</b>	149.75	180	210	220			

P1=Pressione max.continua  
 P2=Pressione max. intermittente  
 P3=Pressione max. di punta

Max. continuous pressure  
 Max. Intermittent pressure  
 Max. peak pressure

(100%)  
 (20 sec.max.)  
 (6 sec.max)

**IDENTIFICAZIONE ASPIRAZIONE/MANDATA / SUCTION/DELIVERY IDENTIFICATION:**

Rotazione antioraria, pompa sinistra Anti-clockwise rotation, left pump	Rotazione oraria, pompa destra Clockwise rotation, right pump
<p>Vista FRONTALE FRONT</p>	<p>Vista FRONTALE FRONT</p>

**MOMENTO PESO / MASS MOMENT**

$M_{amm.} = s \times G \text{ (Nm)}$

Baricentro  
Center of mass

**G**=Peso in N (Peso in Kg x 9.81)  
**G**=Weight in N (Weight in Kg x 9.81)

Tipo pompa - Pump type	<b>S</b>
<b>NPGH-63</b>	84
<b>NPGH-73</b>	86
<b>NPGH-84</b>	89
<b>NPGH-100</b>	91
<b>NPGH-116</b>	94
<b>NPGH-133</b>	97
<b>NPGH-150</b>	100

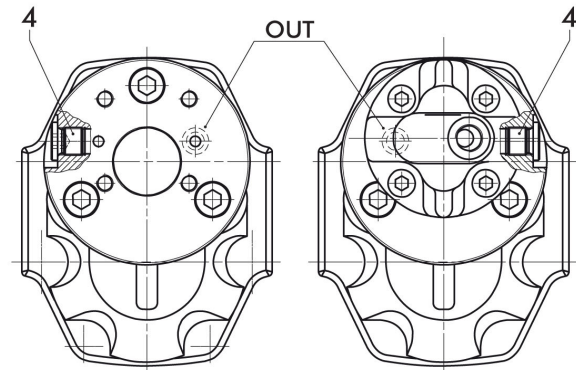
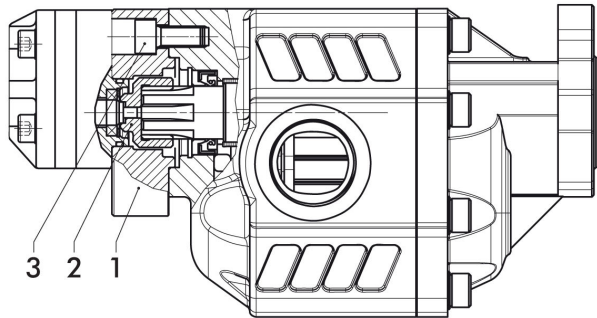
**Pompe 1P**  
**1P pumps**

 Montaggio pompa 1P Dx  
 Mounting pump 1P R

 Montaggio pompa 1P Sx  
 Mounting pump 1P L

**Kit montaggio codice: 10502000101**  
**Mounting kit:**
**Coppia max.**  
**Max. torque 21,5 Nm**

Pos.	Codice Code	Descrizione Description	Q.
1	52800700817	Flangia per montaggio pompe 1P Destra/Sinistra Mounting flange for pumps 1P Left/Right	1
2	11400400853	Manicotto Coupling	1
3	50200400538	Vite TCE M10x22 UNI 5931 CL 12.9 Hex head screw M10x22 UNI 5931 CL 12.9	3
4	11500600117	Tappo TCE 1/4" DIN 908 Hex head plug 1/4" DIN 908	1

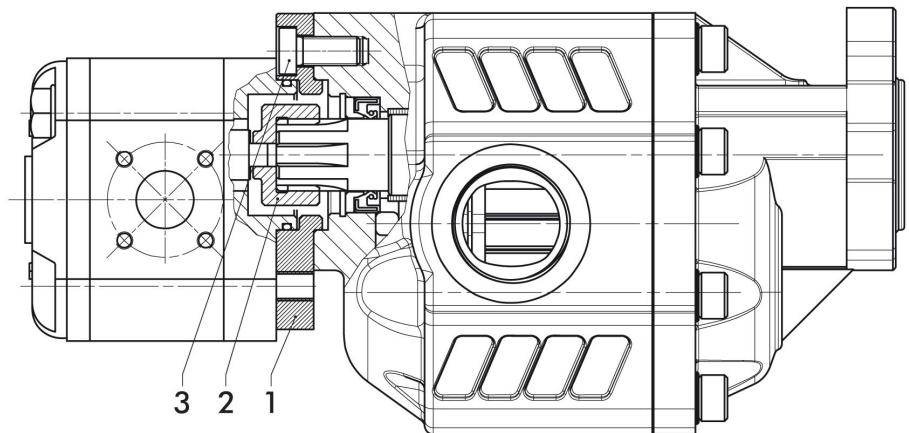
**Pompe 2P**  
**2P pumps**

**L'applicazione è da utilizzare solo con le pompe:**  
**The assembly should be used only with the following pumps:**
**14920009433 4cc destra/right**  
**14920009442 4cc sinistra/left**  
**14920009451 6cc destra/right**  
**14920009460 6cc sinistra/left**

**Kit montaggio codice: 10502000209**  
**Mounting kit:**
**Coppia max.**  
**Max. torque 70 Nm**

Pos.	Codice Code	Descrizione Description	Q.tà Q.ty
1	52800700808	Flangia per montaggio pompe 2P Mounting flange for pumps 2P	1
2	11400400844	Manicotto Coupling	1
3	50200000149	Vite TCE M10x22 DIN 7984 CL 10.9 Hex head screw M10x22 DIN 7984 CL 10.9	3