

**SUPPORTO INCLINATO N-FORCE
CON STAFFA PER VOLVO FH
BRACKET KIT FOR N-FORCE
FOR VOLVO FH**

CODICE ORDINAZIONE
ORDER CODE

100-002-70252

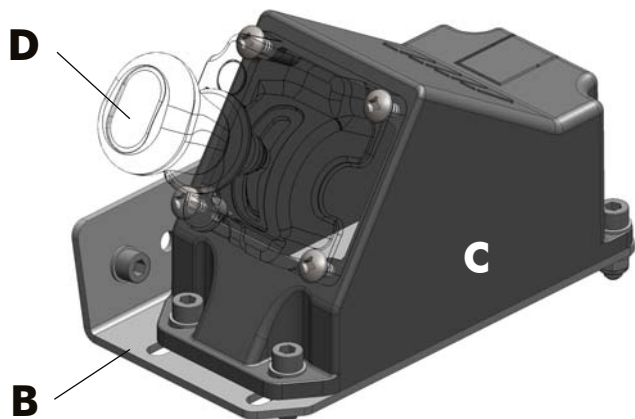

Kit appositamente studiato per fissare i deviatori pneumatici serie N-FORCE sul supporto sedile del veicolo VOLVO FH.

Assembly kit especially designed to mount air controls series N-FORCE on the bracket driver's seat of VOLVO FH

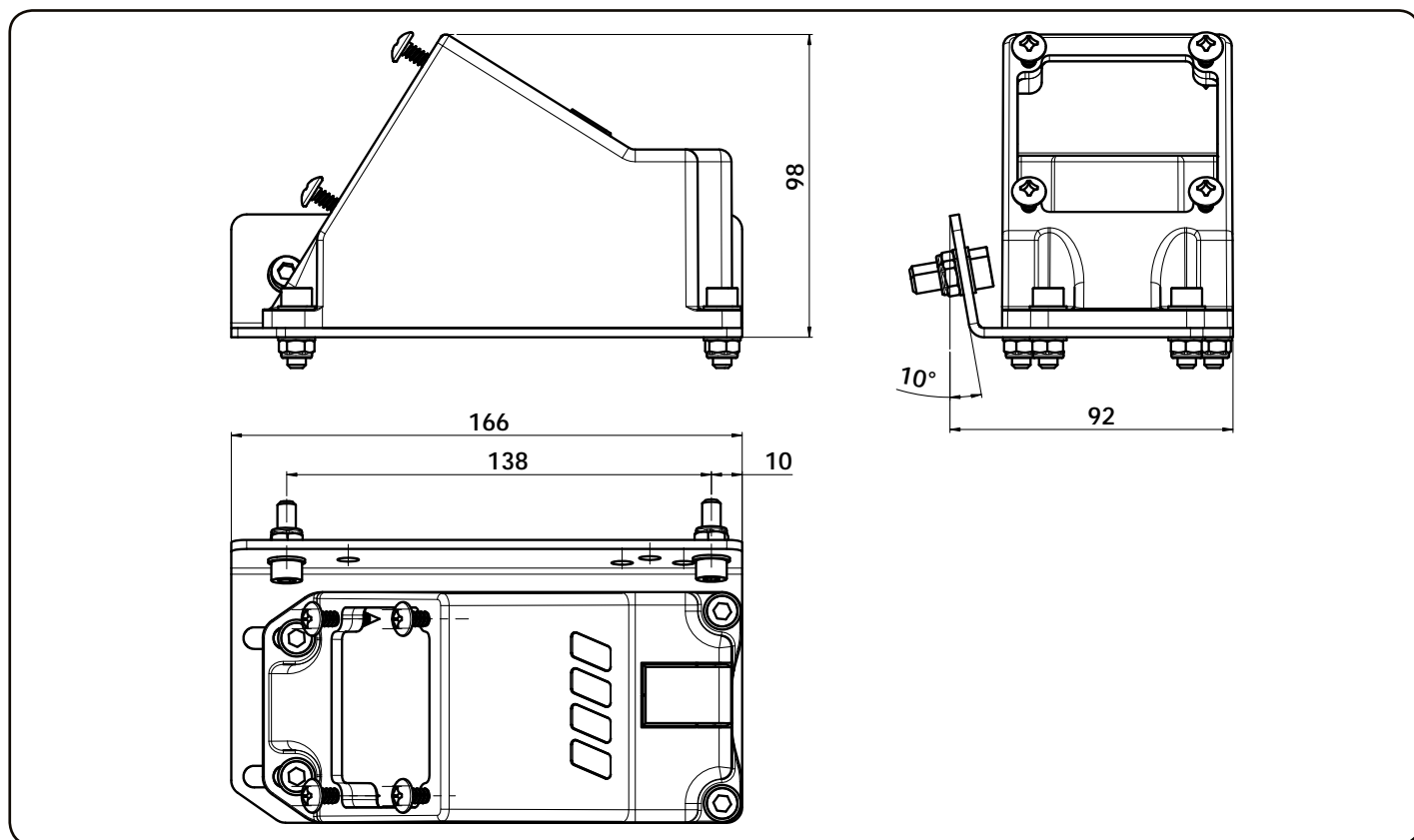

ISTRUZIONI DI MONTAGGIO / MOUNTING INSTRUCTIONS

- 1 - Montare la piastra **B** al sedile. Montare il supporto **C** sulla piastra **B**. Collegare i tubi dell'aria al deviatore pneumatico N-FORCE **D** e fissarlo al supporto **C** con le 4 viti autofilettanti.
- 1 - Mount the plate **B** to driver's seat. Mount the bracket **C** on plate **B**. Connect the air pipe into the air control N-FORCE **D** and fix it on the bracket **C** by using the 4 self-tapping screws.



ATTENZIONE: tutte le operazioni relative al montaggio, devono essere eseguite **IN SICUREZZA** secondo le norme vigenti.

ATTENTION: all the operations related to the assembling of these components have to be carried out in respect of the current **SAFETY** regulations in place

ESEMPIO DI MONTAGGIO / MOUNTING EXAMPLE



In caso di impossibilità o difficoltà di utilizzo o realizzo di fori filettati sul supporto del sedile, è consigliato l'uso degli inserti filettati inclusi nella confezione. Per il montaggio degli stessi è necessario realizzare fori con punta $\varnothing 9$ ed utilizzare l'apposito attrezzo di montaggio.

In case of difficulties while making or using the threaded holes on the seat's support, it is recommended to use the inserts included in the package. For mounting these inserts it is necessary to drill holes $\varnothing 9$ and using the specifying mounting tool.

pag.2

OMFB
HYDRAULIC COMPONENTS

O.M.F.B. S.p.A. Hydraulic Components
We reserve the right to make any changes without notice.
Edition 2010.11 No reproduction, however partial, is permitted.
Via Cave, 7/9 25050 Provaglio d'Iseo (Brescia) Italy Tel.: +39.030.9830611
Fax: +39.030.9839207-208 Internet:www.omfb.it e-mail:contatti@omfb.it

COMPANY WITH
QUALITY SYSTEM
CERTIFIED BY DNV GL
= ISO 9001:2015 =